

FE100-50-EM

FlexPro® Series

Product Status: Active

SPECIFICATIONS

Current Peak	100 A
Current Continuous	50 A
DC Supply Voltage	20 – 90 VDC
Network Communication	EtherCAT

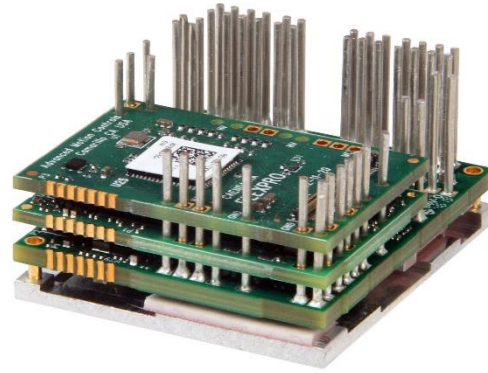

The **FE100-50-EM** is a FlexPro® series servo drive with IMPACT™ architecture.

The **FE100-50-EM** offers full tuning control of all servo loops and is designed to drive brushed and brushless servo motors, and closed loop stepper motors. The drive accepts a variety of external command signals, or can use the built-in Motion Engine, an internal motion controller used with Sequencing and Indexing commands. Programmable digital and analog I/O are included to enhance interfacing with external controllers and devices.

The **FE100-50-EM** features an EtherCAT® interface for network communication using CANopen over EtherCAT (CoE) and USB connectivity for drive configuration and setup. All drive and motor parameters are stored in non-volatile memory.

IMPACT™ (Integrated Motion Platform And Control Technology) combines exceptional processing capability and high-current components to create powerful, compact, feature-loaded servo solutions. IMPACT™ is used in all FlexPro® drives and is available in custom products as well.

FEATURES

- CoE – Based on DSP-402 Device Profile for Drives and Motion Control
- Synchronization using Distributed Clocks
- Position Cycle Times down to 100µs
- Four Quadrant Regenerative Operation
- Programmable Gain Settings
- PIDF Velocity Loop
- Compact Size, High Power Density
- On-the-Fly Mode Switching
- On-the-Fly Gain Set Switching
- Dedicated Safe Torque Off (STO) Inputs
- Space Vector Modulation (SVM) Technology

Feedback Supported	<ul style="list-style-type: none"> • Absolute Encoder <ul style="list-style-type: none"> ○ BiSS C-Mode ○ EnDat 2.2 • Incremental Encoder • Hall Sensors • Aux Incremental Encoder • Tachometer (±10V) 	Motors Supported	<ul style="list-style-type: none"> • Three Phase • Single Phase • Stepper 	Modes of Operation	<ul style="list-style-type: none"> • Profile Modes • Cyclic Synchronous Modes • Current • Velocity • Position
Command Sources	<ul style="list-style-type: none"> • Over the Network • ±10V Analog • Sequencing • Indexing • Jogging • Step & Direction • Encoder Following 	Inputs / Outputs	<ul style="list-style-type: none"> • 4 Programmable Digital Inputs • 3 Programmable Digital Outputs • 1 Programmable Analog Input 	Agency Approvals	<ul style="list-style-type: none"> • RoHS • UL (Pending) • CE (Pending) • TUV Rheinland (STO) (Pending)

BLOCK DIAGRAM

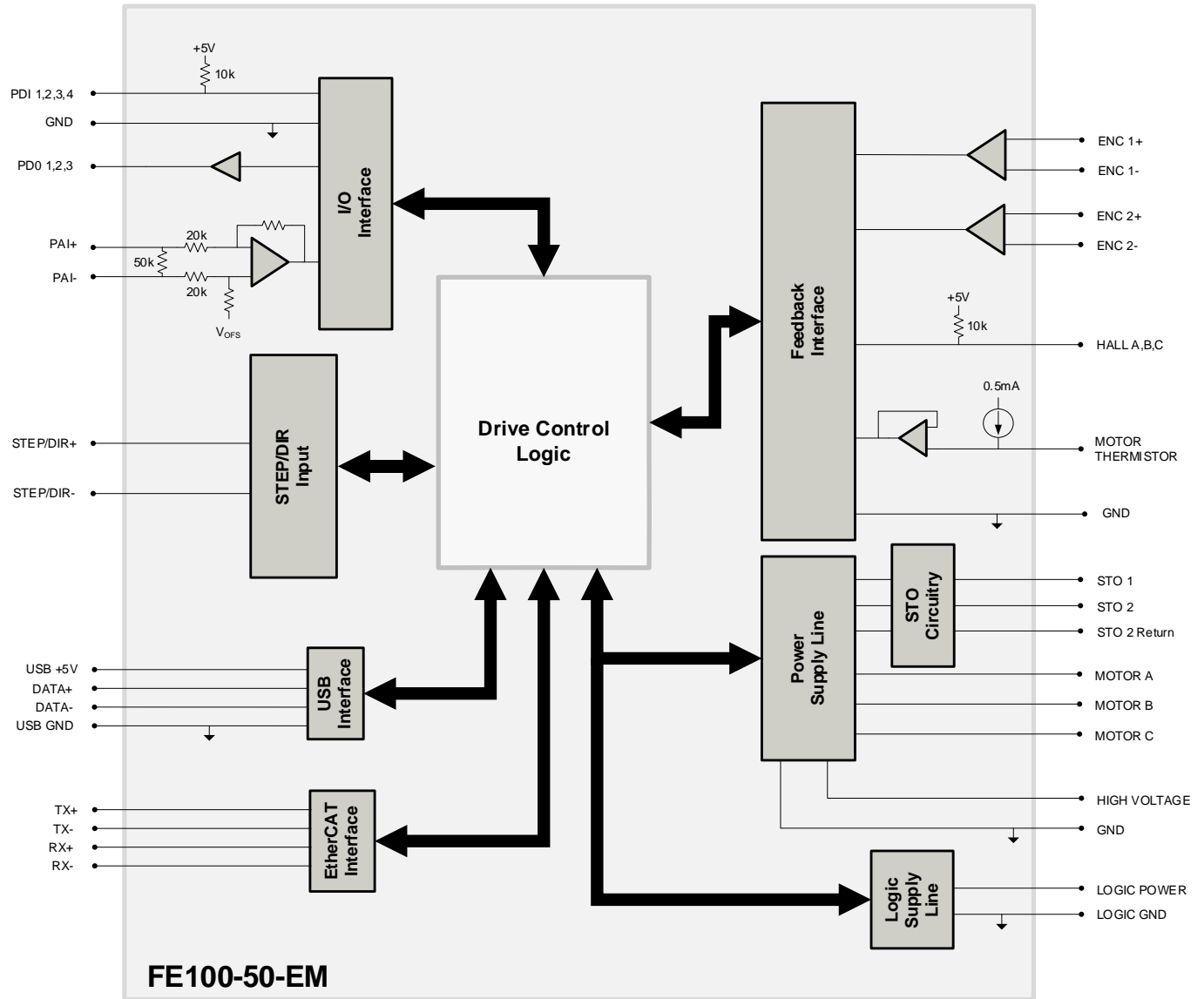

INFORMATION ON APPROVALS AND COMPLIANCES



The RoHS Directive restricts the use of certain substances including lead, mercury, cadmium, hexavalent chromium and halogenated flame retardants PBB and PBDE in electronic equipment.

SPECIFICATIONS

Description	Electrical Specifications		Value
	Units		
DC Supply Input Range	VDC	20 – 90	
DC Supply Undervoltage	VDC	15	
DC Supply Overvoltage	VDC	100	
Logic Supply Input Range (required)	VDC	10 – 55	
Safe Torque Off Voltage (Default)	VDC	5	
Minimum Required External Bus Capacitance	μF	270	
Maximum Peak Current Output ¹	A (Arms)	100 (70.7)	
Maximum Continuous Current Output ²	A (Arms)	50 (50)	
Efficiency at Rated Power	%	99	
Maximum Continuous Output Power	W	4455	
Maximum Power Dissipation at Rated Power	W	45	
Minimum Load Inductance (line-to-line) ³	μH	250	
Switching Frequency	kHz	20	
Maximum Output PWM Duty Cycle	%	83	

Description	Control Specifications		Value
	Units		
Communication Interfaces ⁴	-	EtherCAT® (USB for configuration)	
Command Sources	-	±10 V Analog, Over the Network, Sequencing, Indexing, Jogging, Step & Direction, Encoder Following	
Feedback Supported	-	Absolute Encoder (BiSS C-Mode, EnDat 2.2), Hall Sensors, Incremental Encoder, Auxiliary Incremental Encoder, Tachometer (±10V)	
Commutation Methods	-	Sinusoidal, Trapezoidal	
Modes of Operation	-	Profile Modes, Cyclic Synchronous Modes, Current, Velocity, Position	
Motors Supported ⁵	-	Three Phase (Brushless Servo), Single Phase (Brushed Servo, Voice Coil, Inductive Load), Stepper (2- or 3-Phase Closed Loop)	
Hardware Protection	-	40+ Configurable Functions, Over Current, Over Temperature (Drive & Motor), Over Voltage, Short Circuit (Phase-Phase & Phase-Ground), Under Voltage	
Programmable Digital Inputs/Outputs	-	4/3	
Programmable Analog Inputs/Outputs	-	1/0	
Primary I/O Logic Level	-	5 VDC, not isolated	
Current Loop Sample Time	μs	50	
Velocity Loop Sample Time	μs	100	
Position Loop Sample Time	μs	100	
Maximum Encoder Frequency	MHz	20 (5 pre-quadrature)	

Description	Mechanical Specifications		Value
	Units		
Size	mm (in)	43.2 x 38.1 x 17.0 (1.70 x 1.50 x 0.7)	
Weight	g (oz)	45.4 (1.6)	
Ambient Operating Temperature Range ⁶	°C (°F)	0 – 65 (32 – 149)	
Storage Temperature Range	°C (°F)	-40 – 85 (-40 – 185)	
Relative Humidity	-	0-95%, non-condensing	
Form Factor	-	PCB Mounted	
P1 SIGNAL CONNECTOR*	-	80-pin 0.4mm spaced connector	
TERMINAL PINS	-	51x Terminal Pins	

Notes

1. Capable of supplying drive rated peak current for 2 seconds with 2 second foldback to continuous value. Longer times are possible with lower current limits.
2. Continuous I_{Arms} value attainable when RMS Charge-Based Limiting is used.
3. Lower inductance is acceptable for bus voltages well below maximum. Use external inductance to meet requirements.
4. EtherCAT® is a registered trademark and patented technology, licensed by Beckhoff Automation GmbH, Germany.
5. Maximum motor speed for stepper motors is 600 RPM. Consult the hardware installation manual for 2-phase stepper wiring configuration.
6. Additional cooling and/or heatsink may be required to achieve rated performance. Repeated over temperature events may cause damage to the drive due to the drive's high power density. Ensure that proper thermal management is adhered to during drive operation.

***Mating Connector Kit**

Surface mount board connector for P1 and board spacers can be ordered as a kit using ADVANCED Motion Controls' part number **KC-MC1XFE01**.

PIN FUNCTIONS

P1 – Signal Connector				P1 – Signal Connector			
Pin	Name	Description / Notes	I/O	Pin	Name	Description / Notes	I/O
1	GROUND	Ground	GND	2	GROUND	Ground	GND
3	PAI-1+	Differential Programmable Analog Input or Reference Signal Input (12-bit Resolution)	I	4	DATA+ USB	USB Data Channel	I/O
5	PAI-1-		I	6	DATA- USB		I/O
7	THERMISTOR	Motor Thermal Protection.	I	8	GROUND	Ground	GND
9	GROUND	Ground	GND	10	SCLA	I ² C Data Signals for Addressing, Network Error LED, and Bridge Status LED. See Hardware Manual for more info.	O
11	ENC 1 DATA+ / A+	Differential Data Line for Absolute Encoders (BiSS: SLO+/-) or Differential Incremental Encoder A.	I/O	12	SDAA		I/O
13	ENC 1 DATA- / A-		I/O	14	HALL A	Single-ended Commutation Sensor Inputs	I
15	ENC 1 CLK+ / B+	Differential Clock Line for Absolute Encoders (BiSS: MA+/-) or Differential Incremental Encoder B.	I/O	16	HALL B		I
17	ENC 1 CLK- / B-		I/O	18	HALL C		I
19	GROUND	Ground	GND	20	GROUND	Ground	GND
21	ENC 1 REF+ / I+	Differential Reference Mark for Absolute Encoders (Leave open for BiSS) or Differential Incremental Encoder Index.	I	22	ENC 2 A+	Differential Incremental Encoder A.	I
23	ENC 1 REF- / I-		I	24	ENC 2 A-		I
25	RESERVED	Reserved. Do not connect.	-	26	ENC 2 B+	Differential Incremental Encoder B.	I
27	RESERVED	Reserved. Do not connect.	-	28	ENC 2 B-		I
29	RESERVED	Reserved. Do not connect.	-	30	ENC 2 I+	Differential Incremental Encoder Index.	I
31	PDI-1	Programmable Digital Input	I	32	ENC 2 I-		I
33	PDI-2	Programmable Digital Input	I	34	PDO-1	Programmable Digital Output (TTL/8mA)	O
35	PDI-3	Programmable Digital Input	I	36	PDO-2	Programmable Digital Output (TTL/8mA)	O
37	PDI-4	Programmable Digital Input	I	38	PDO-3	Programmable Digital Output (TTL/8mA)	O
39	GROUND	Ground	GND	40	GROUND	Ground	GND
41	TX- IN	Transmit Line IN (100 Base TX)	I	42	TX- OUT	Transmit Line OUT (100 Base TX)	O
43	TX+ IN		I	44	TX+ OUT		O
45	RX- IN	Receive Line IN (100 Base TX)	I	46	RX- OUT	Receive Line OUT (100 Base TX)	O
47	RX+ IN		I	48	RX+ OUT		O
49	+3V BIAS IN	+3V Supply for Transformer/Magnetics Bias	O	50	+3V BIAS OUT	+3V Supply for Transformer/Magnetics Bias	O
51	LINK/ACT IN	Link and Activity Indicator for IN port. Function based on protocol specification. See Hardware Information below.	I/O	52	LINK/ACT OUT	Link and Activity Indicator for OUT port. Function based on protocol specification. See Hardware Information below.	I/O
53	STATUS	Run State Indicator for Network. Function based on protocol specification. See Hardware Information below.	I/O	54	RESERVED	Reserved. Do not connect.	-
55	RESERVED	Reserved. Do not connect.	-	56	RESERVED	Reserved. Do not connect.	-
57	RESERVED	Reserved. Do not connect.	-	58	RESERVED	Reserved. Do not connect.	-
59	GROUND	Ground	GND	60	GROUND	Ground	GND
61	RESERVED	Reserved. Do not connect.	-	62	RESERVED	Reserved. Do not connect.	-
63	RESERVED	Reserved. Do not connect.	-	64	RESERVED	Reserved. Do not connect.	-
65	RESERVED	Reserved. Do not connect.	-	66	RESERVED	Reserved. Do not connect.	-
67	RESERVED	Reserved. Do not connect.	-	68	STEP	Step Input.	I
69	RESERVED	Reserved. Do not connect.	-	70	DIR	Direction Input.	I
71	RESERVED	Reserved. Do not connect.	-	72	RESERVED	Reserved. Do not connect.	-
73	+5V	+5VDC unprotected supply (See Note 1)	O	74	RESERVED	Reserved. Do not connect.	-
75	+5V USER	+5VDC User Supply for feedback and local logic (See Note 1)	O	76	+3V3 OUT	+3.3VDC Supply Output for local logic signals (100 mA max)	O
77	+5V USER		O	78	+3V3 OUT		O
79	GROUND	Ground	GND	80	GROUND	Ground	GND

Connector Information	80-pin, 0.4mm spaced connector	
Mating Connector Details	PANASONIC; P/N AXT380224	
Mating Connector Included with Drive	No	

Notes
 Total current through pins P1-73/75/77 should not exceed 300mA, while no single pin should be loaded more than 150mA.

Drive Status LED and Node Addressing

SCLA (P1-10); SDAA (P1-12)

The SCLA and SDAA pins allow Drive Status LED monitoring and Node Addressing to be performed with an I²C bus I/O expander. For more information on how to utilize and configure the I/O expander into an interface board, consult the hardware installation manual.

TERMINAL PIN LOCATIONS

The 51 Terminal Pins provide connection to the high power drive signals. Terminal Pins must be soldered to an interface board.

Pin	Name	Description / Notes	I/O
T1	STO-1 INPUT	Safe Torque Off – Input 1	I
T2	STO RETURN	Safe Torque Off Return	STORET
T3	STO-2 INPUT	Safe Torque Off – Input 2	I
T4	LOGIC PWR	Logic Supply Input (10-55 VDC) (required)	I
T5	POWER GND	Ground.	GND
T6	POWER GND		GND
T7	POWER GND		GND
T8	POWER GND		GND
T9	MOTOR C	Motor Phase C. All provided motor phase output pins must be used.	O
T10	MOTOR C		O
T11	MOTOR C		O
T12	MOTOR C		O
T13	MOTOR C		O
T14	MOTOR C		O
T15	MOTOR C		O
T16	MOTOR C	O	
T17	HV	DC Supply Input (20-90 VDC). Minimum 270 µF external capacitance required between HV and POWER GND.	I
T18	HV		I
T19	HV		I
T20	HV		I
T21	HV		I
T22	HV		I
T23	HV		I
T24	HV		I
T25	HV		I
T26	HV		I
T27	MOTOR B	Motor Phase B. All provided motor phase output pins must be used.	O
T28	MOTOR B		O
T29	MOTOR B		O
T30	MOTOR B		O
T31	MOTOR B		O
T32	MOTOR B		O
T33	MOTOR B		O
T34	MOTOR B	O	
T35	POWER GND	Ground.	GND
T36	POWER GND		GND
T37	POWER GND		GND
T38	POWER GND		GND
T39	POWER GND		GND
T40	POWER GND		GND
T41	POWER GND		GND
T42	POWER GND	GND	
T43	POWER GND	GND	
T44	MOTOR A	Motor Phase A. All provided motor phase output pins must be used.	O
T45	MOTOR A		O
T46	MOTOR A		O
T47	MOTOR A		O
T48	MOTOR A		O
T49	MOTOR A		O
T48	MOTOR A		O
T49	MOTOR A		O
T50	MOTOR A		O
T51	MOTOR A		O

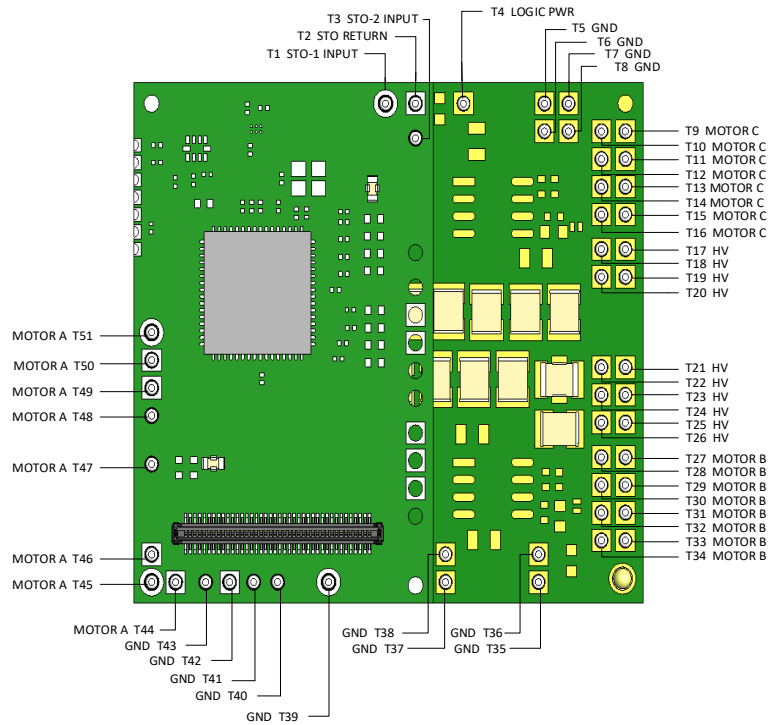

Terminal Pin Details

Safe Torque Off (STO) Inputs

The Safe Torque Off (STO) inputs are dedicated +5VDC sinking single-ended inputs. For applications not using STO functionality, disabling of the STO feature is required for proper drive operation. STO may be disabled by following the STO Disable wiring instructions as given in the hardware installation manual. Consult the hardware installation manual for more information.

MOUNTING DIMENSIONS

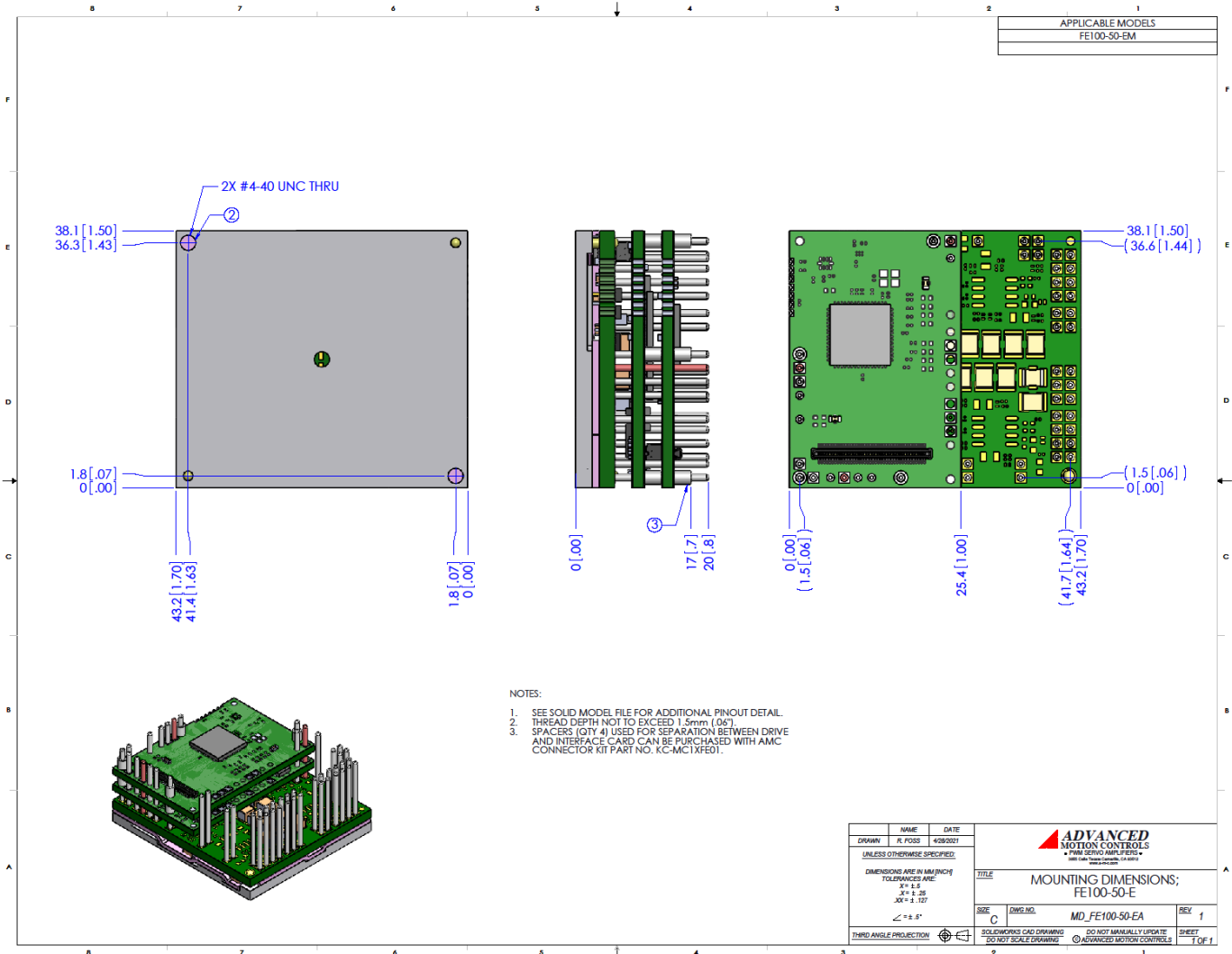

PART NUMBERING AND CUSTOMIZATION INFORMATION

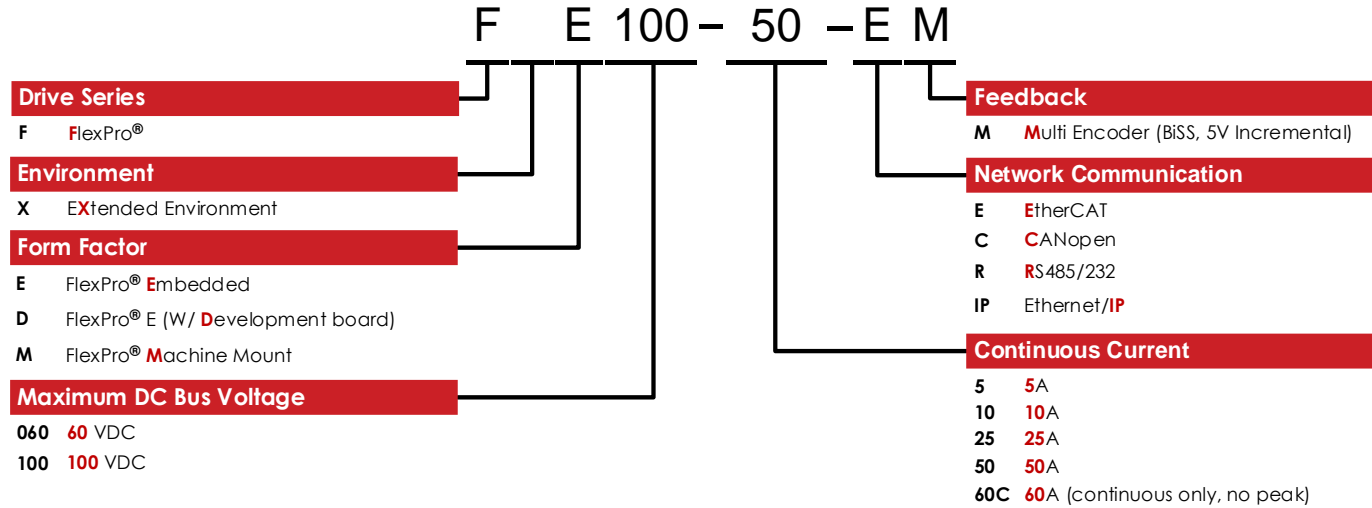

ADVANCED Motion Controls also has the capability to promptly develop and deliver specified products for OEMs with volume requests. Our Applications and Engineering Departments will work closely with your design team through all stages of development in order to provide the best servo drive solution for your system. Equipped with on-site manufacturing for quick-turn customs capabilities, ADVANCED Motion Controls utilizes our years of engineering and manufacturing expertise to decrease your costs and time-to-market while increasing system quality and reliability.

Examples of Customized Products

- | | |
|--|--|
| <ul style="list-style-type: none"> ▲ Optimized Footprint ▲ Private Label Software ▲ OEM Specified Connectors ▲ No Outer Case ▲ Increased Current Resolution ▲ Increased Temperature Range ▲ Custom Control Interface ▲ Integrated System I/O | <ul style="list-style-type: none"> ▲ Tailored Project File ▲ Silkscreen Branding ▲ Optimized Base Plate ▲ Increased Current Limits ▲ Increased Voltage Range ▲ Conformal Coating ▲ Multi-Axis Configurations ▲ Reduced Profile Size and Weight |
|--|--|

Feel free to contact us for further information and details!

Available Accessories

ADVANCED Motion Controls offers a variety of accessories designed to facilitate drive integration into a servo system. Visit www.a-m-c.com to see which accessories will assist with your application design and implementation.

Development Board

The FE100-50-EM is offered in a pre-soldered development board assembly to provide easy connections to motor, power, and signal functions. The development board assembly can be ordered as model number **FD100-50-EM**.



All specifications in this document are subject to change without written notice. Actual product may differ from pictures provided in this document.