

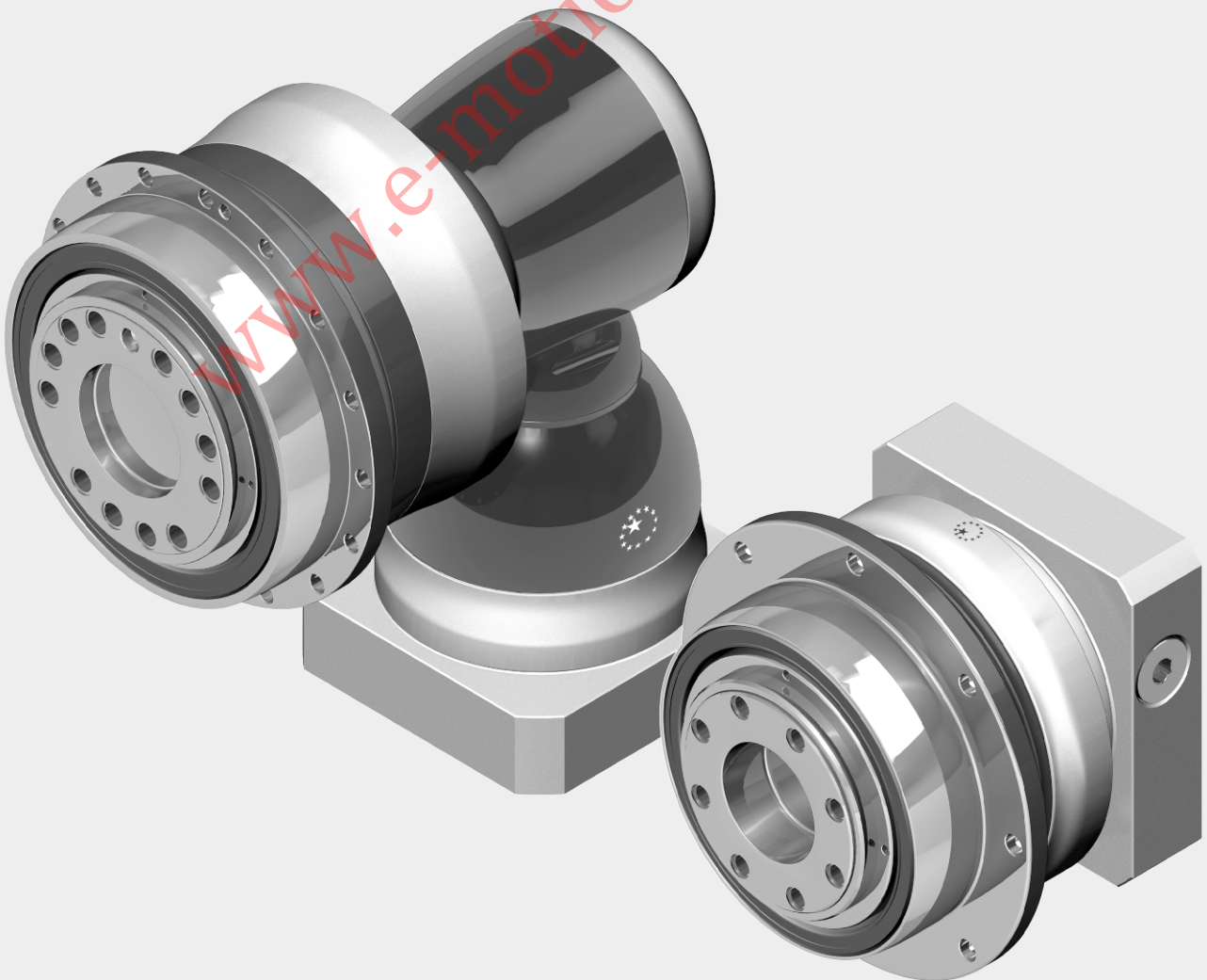

APEX DYNAMICS, INC.

**NEW GENERATION
PLANETARY GEARBOX**

AH / AHK Series



Gearbox Series - AH / AHK

► Features:

- High Torque
- High efficiency
- Long-Term persistence of reduced backlash
- Low noise
- Long service life
- Limited temperature rise
- Optimized output torque
- Optimized Inertia moment
- Flexible mounting diameters



Ordering Code - AH / AHK Gearbox

AH090	—	005⁽¹⁾	/	MOTOR
AHS090	—	005⁽¹⁾		
AHK090	—	005⁽¹⁾	/	MOTOR
AHKA285⁽³⁾				Motor Type
AHKB090⁽³⁾				Ratio
				Gearbox Size

AHS is the AH version with input “SHAFT” instead of input “HUB”⁽⁴⁾

Gearbox Size

AH 064 / 090 / 110 / 140 / 200 / 255 / 285 / 355 / 450

AHK 064 / 090 / 110 / 140 / 200 / 255 / 285 / 355 / 450

Ratio⁽²⁾

**AH 4 / 5 / 7 / 10
16 / 20 / 21 / 25 / 28 / 31 / 35 / 40 / 46 / 50 / 61 / 70 / 91 / 100**

AHK (2 Stg.) 12 / 15 / 16 / 20 / 25 / 28 / 35 / 40 / 49 / 50 / 70 / 100

AHKA (3 Stg.) 100 / 125 / 140 / 175 / 200 / 250 / 350 / 500 / 700 / 1,000

AHKB (3 Stg.) 64 / 84 / 100 / 125 / 140 / 175 / 200 / 250 / 280 / 350 / 400 / 500 / 700 / 1,000

AHK (4 Stg.) 1,225 / 1,400 / 1,750 / 2,000 / 2,800 / 3,500 / 5,000 / 7,000 / 10,000

AHKC 4 / 5 / 7 / 8 / 10 / 21 / 31 / 46 / 61 / 91

Motor Type

Manufacturer and Model

(1) Ratio (I=N_{in}/N_{out}).

(2) Please refer to the specifications for the ratios provided in each series.

(3) Please refer to page 06.

(4) The customization detail please contact with APEX sales.



©2020 by APEX DYNAMICS, INC.

APEX DYNAMICS, INC. reserves modification and copyrights of all technical specifications, illustrations and drawings in this catalog in allowance for continuous products development and advancement. For the newest data and information, please visit <http://www.e-motionsupply.com/>

Performance - AH Gearbox

Model No.	Stage	Ratio ⁽¹⁾	AH064	AH090	AH110	AH140	AH200	AH255	AH285	AH355	AH450	
Nominal Output Torque T_{2N} By n_{1N}	1	4	100	205	380	765	1,415	-	-	-	-	
		5	85	185	325	660	1,225	1,905	3,505	6,250	11,520	
		7	60	135	260	515	980	1,530	2,630	5,045	9,875	
		10	24	55	160	315	700	1,070	1,810	3,345	7,160	
	2	16	100	205	400	805	1,485	-	-	-	-	
		20	100	205	400	810	1,495	1,990	3,660	-	-	
		21	90	195	345	700	1,295	2,005	3,685	6,525	12,405	
		25	90	195	345	700	1,295	2,005	3,685	-	-	
		28	60	205	405	820	1,510	-	-	-	-	
		31	60	135	280	560	1,050	1,620	2,590	5,280	10,510	
		35	75	195	350	705	1,310	2,030	3,725	-	-	
		40	40	96	220	615	1,260	-	-	-	-	
		46	24	55	160	335	660	1,005	1,700	3,400	7,125	
		50	50	120	275	715	1,325	2,050	3,765	-	-	
		61	60	135	300	585	1,095	1,670	2,675	5,445	10,795	
		70	60	135	300	585	1,095	1,670	2,675	-	-	
		91	24	55	160	345	660	1,005	1,700	3,400	7,000	
100	24	55	160	345	660	1,005	1,700	-	-			
Emergency Stop Torque T_{2NOT}	Nm	1,2	4~100	3 times T_{2N}								
Max. Acceleration Torque T_{2B}	Nm	1,2	4~100	1.5 times T_{2N}								
No Load Running Torque ⁽³⁾	Nm	1	4~10	0.45	0.7	1.4	3.5	7	11	14	25	40
		2	16~100	0.2	0.3	0.6	1.3	2.2	3.5	4.5	13	21
Backlash ⁽²⁾	arcmin	1	4~10	≤ 2	≤ 1	≤ 1	≤ 1	≤ 1	≤ 1	≤ 1	≤ 1	≤ 1
		2	16~100	≤ 3	≤ 2	≤ 2	≤ 2	≤ 2	≤ 2	≤ 2	≤ 2	≤ 2
Torsional Rigidity	Nm/arcmin	1,2	4~100	8	22	60	115	395	650	1,050	2,850	5,700
Nominal Input Speed n_{1N}	rpm	1	4~10	5,000	3,600	3,600	3,000	2,700	2,400	2,100	1,500	1,000
		2	16~100	5,000	4,600	4,600	4,000	3,700	3,400	3,100	2,500	2,000
Max. Input Speed n_{1B}	rpm	1	4~10	7,000	6,000	6,000	5,000	4,500	4,000	3,500	3,000	2,500
		2	16~100	7,000	7,000	7,000	6,000	5,500	5,000	4,500	4,000	3,500
Max. Axial Load F_{2a} ⁽⁴⁾	N	1,2	4~100	1,690	2,220	4,070	8,530	17,000	26,900	39,200	101,500	143,700
Max. Tilting Moment M_{2K} ⁽⁴⁾	Nm	1,2	4~100	120	280	480	1,310	3,530	5,920	9,230	29,100	63,300
Operating Temp	°C	1,2	4~100	-10° C ~ 90° C								
Degree of Gearbox Protection		1,2	4~100	IP67								
Lubrication		1,2	4~100	Synthetic lubrication grease								
Mounting Position		1,2	4~100	All directions								
Running Noise ⁽³⁾	dB(A)	1	4~10	≤ 58	≤ 59	≤ 64	≤ 65	≤ 66	≤ 66	≤ 66	≤ 68	≤ 70
		2	16~100	≤ 58	≤ 59	≤ 60	≤ 63	≤ 66	≤ 66	≤ 66	≤ 68	≤ 70
Efficiency η	%	1	4~10	≥ 97%								
		2	16~100	≥ 94%								

(1) Ratio ($i = N_{in} / N_{out}$).

(2) Backlash is measured at 2% of Nominal Output Torque T_{2N} .

(3) The dB values are measured by gearbox with ratio 10 (1-stage) or ratio 100 (2-stage), no loading at 3,000 RPM or at the respective Nominal Input Speed by bigger model size.

By lower ratio and/or higher RPM, the noise level could be 3 to 5 dB higher.

(4) Applied to the output flange center at 100 rpm.

(5) Continuous operation is not recommended.

Inertia - AH Gearbox

Model No.	AH064		AH090		AH110		AH140		AH200		AH255		AH285		AH355		AH450																			
	∅ ^(A) (C3)		1-st.	2-st.	1-st.	2-st.	1-st.	2-st.	1-st.	2-st.	1-st.	2-st.	1-st.	2-st.	1-st.	2-st.	1-st.	2-st.																		
8	kg.cm ²																		-	0.1	-	-	-	-	-	-	-	-	-	-	-	-	-	-	-	
11																			0.17	0.16	-	0.17	-	-	-	-	-	-	-	-	-	-	-	-	-	-
14																			0.21	0.2	0.53	0.21	-	0.53	-	-	-	-	-	-	-	-	-	-	-	-
19																			0.63	-	0.68	0.63	1.83	0.68	-	1.83	-	-	-	-	-	-	-	-	-	-
24																			-	-	4.52	-	5.04	4.52	5.63	5.04	-	5.63	-	-	-	-	-	-	-	-
28																			-	-	-	-	6.33	-	7.18	6.33	-	7.18	-	-	-	-	-	-	-	-
32																			-	-	-	-	8.73	-	10.1	8.73	12.63	10.1	-	12.63	-	-	-	-	-	-
35																			-	-	-	-	14.04	-	15.54	14.04	17.75	15.54	17.35	17.75	28.18	20.8	-	-	-	-
38																			-	-	-	-	19.05	-	21.32	19.05	23.26	21.32	23.61	23.26	28.18	27.05	-	23.6	-	-
42																			-	-	-	-	-	-	23.2	-	25.4	23.2	25.5	25.4	30.52	28.95	-	25.37	-	30.37
48																			-	-	-	-	-	-	56.07	-	61.02	56.07	61.22	61.02	66.85	64.66	-	89.35	-	96.45
55																			-	-	-	-	-	-	-	-	88.51	-	88.86	-	94.91	-	-	102	-	109.06
60																			-	-	-	-	-	-	-	-	-	-	-	-	117.73	-	-	-	-	117.75

(A) ∅ = Input shaft diameter.

(B) For 1-st. of AH355/AH450 please contact APEX for details.

Flange Shaft - AH

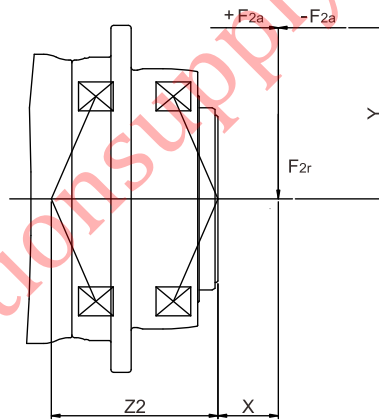
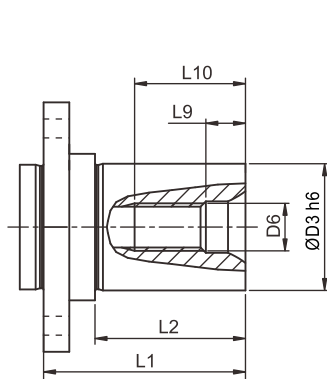

$$M_{2K} = \frac{F_{2a} * Y + F_{2r} * (X + Z2)}{1000}$$

$$M_{2K} : \text{[Nm]}$$

$$F_{2a}, F_{2r} : \text{[N]}$$

$$X, Y, Z2 : \text{[mm]}$$

Dimension	L1	L2	D3 h6	D6	L9	L10	Order Code
AH064	33	23	16	M5	4.8	12.5	FLS-AH064-S16
			22	M8	7.2	19	FLS-AH064-S22
AH090	41	30	22	M8	7.2	19	FLS-AH090-S22
			32	M12	10	28	FLS-AH090-S32
AH110	51	38	32	M12	10	28	FLS-AH110-S32
			40	M16	12	36	FLS-AH110-S40
AH140	54	38	40	M16	12	36	FLS-AH140-S40
			55	M20	15	42	FLS-AH140-S55
AH200	73	52	55	M20	15	42	FLS-AH200-S55
			75	M20	15	42	FLS-AH200-S75
AH255	150	123	90	M24	18	50	FLS-AH255-S90

Note: Dimensions are related to gearbox flange interface.

M2K

AH / AHK	064	090	110	140	200	255	285	355	450
Z2 [mm]	63.7	84.5	106.2	90	122.8	133.2	175.5	220.6	275.3

Note : Applied to the output flange center at 100 rpm

Dimension AH Gearbox

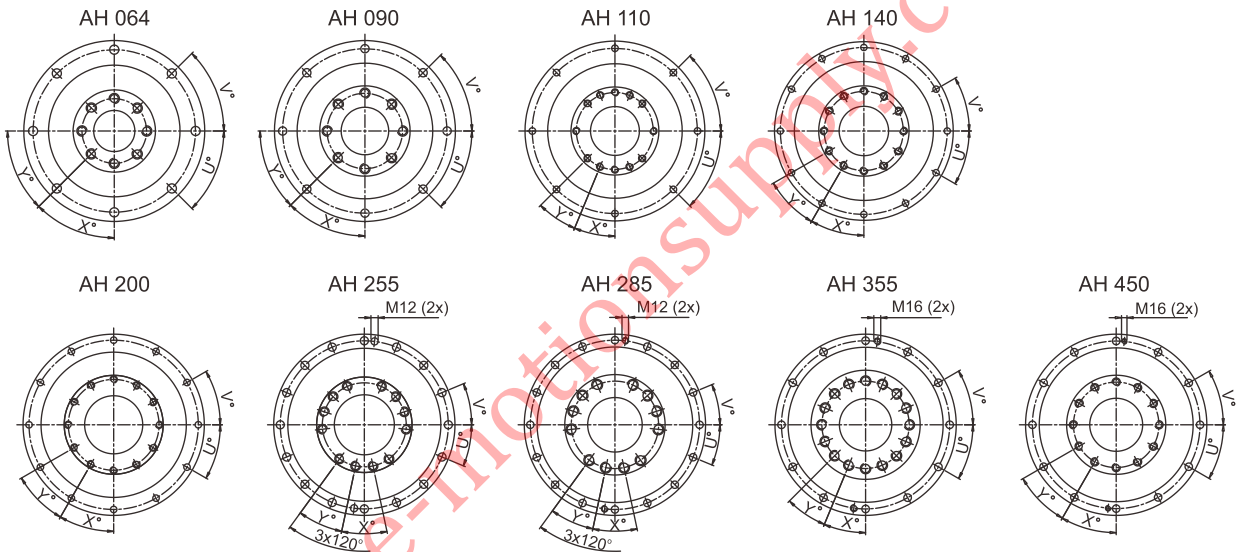
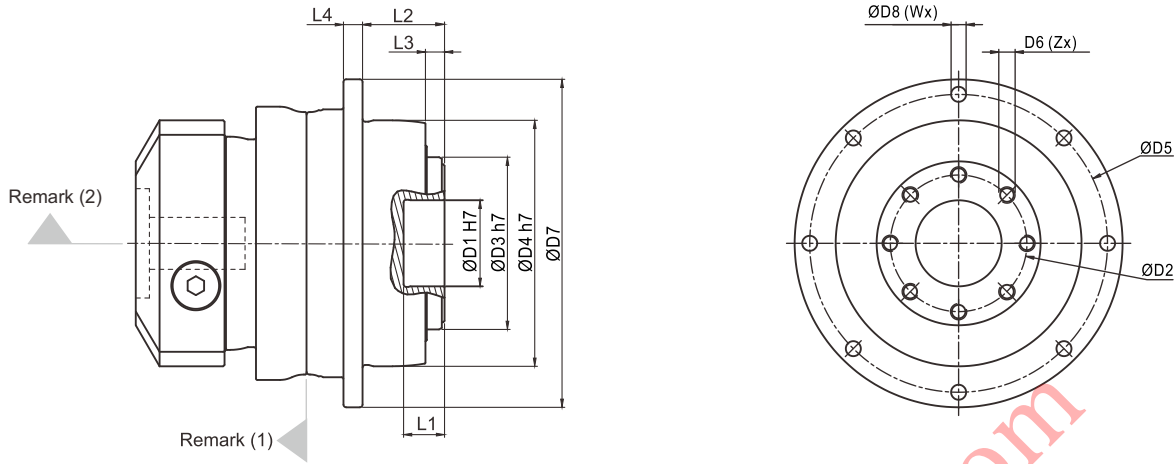

Dimension	AH064	AH090	AH110	AH140	AH200	AH255	AH285	AH355	AH450
D1 H7	20	31.5	40	50	80	100	100	120	155
D2	31.5	50	63	80	125	140	160	200	250
D3 h7	40	63	80	100	160	180	200	250	315
D4 h7	64	90	110	140	200	255	285	355	450
D5	79	109	135	168	233	280	310	385	490
D6 x Pitch x Deep	M5x0.8Px8	M6x1Px10	M6x1Px11	M8x1.25Px15	M10x1.5Px20	M16x2Px25	M20x2.5Px31	M24x3Px32	M30x3.5Px40
D7	88	120	147	180	249.5	302	332	415	530
D8	4.5	5.5	5.5	6.6	9	13.5	13.5	17.5	22
L1	8	15	15	15	16	16	16	35	24
L2	19.5	30	29	38	50	66	75	80	85
L3	4	7	7	7.5	8.5	13.5	16.5	20	20
L4	5	7	8	10	12	18	20	45	60
X in Degree	45	45	22.5	30	30	24	24	22.5	30
Y in Degree	45	45	22.5	30	30	24	24	22.5	30
Z	8	8	12	12	12	12	12	16	12
U in Degree	45	45	45	30	30	22.5	22.5	30	30
V in Degree	45	45	45	30	30	22.5	22.5	30	30
W	8	8	8	12	12	16	16	12	12

(1) Dimensions are related to motor interface. Please contact APEX for details.

(2) As alternative to input "HUB", input "SHAFT" is also available, please find in page 06.

Dimension - AHS (Input Shaft as Option)

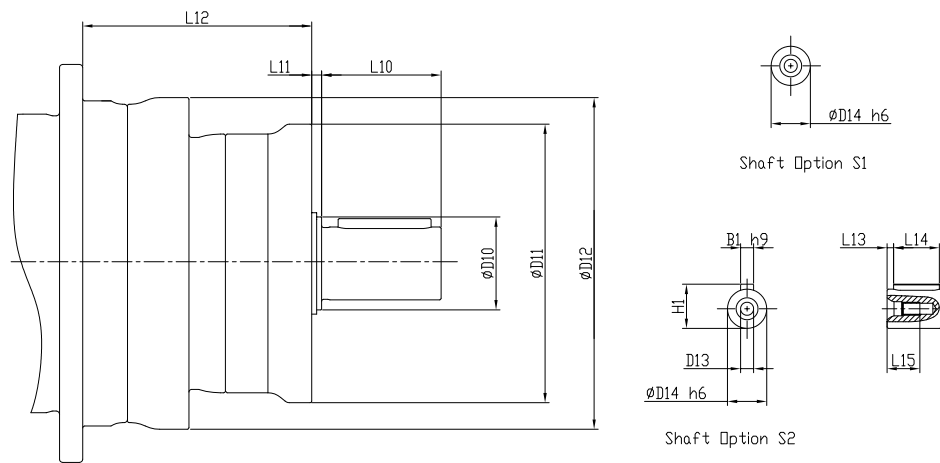

Dimension	Stage	AHS064	AHS090	AHS100	AHS140	AHS200	AHS255	AHS285	AHS355	AHS450
D10	1	20	28	35	50	70	70	75	-	-
	2	17	20	28	35	50	70	70	75	75
D11	1	68	84	93	118	178	180	225	-	-
	2	60	68	84	93	118	178	180	225	225
D12	1,2	76	100	132	160	232	262	301.5	362	466
D13	1	M4x0.7P	M8x1.25P	M10x1.5P	M12x1.75P	M16x2P	M20x2.5P	M20x2.5P	-	-
	2	M3x0.5P	M4x0.7P	M8x1.25P	M10x1.5P	M12x1.75P	M16x2P	M20x2.5P	M20x2.5P	M20x2.5P
D14 h6	1	12	22	28	38	45	55	60	-	-
	2	10	12	22	28	38	45	55	55	60
L10	1	18	36	42	58	82	82	105	-	-
	2	15	18	36	42	58	82	82	82	105
L11	1	3	3	4	5	10	11	11	-	-
	2	3	3	3	4	5	10	11	11	11
L12	1	57.5	69	88	107.5	151.5	149	216	-	-
	2	73	85	110	136	174.5	210	255.5	278.5	374
L13	1	2	3	5	5	5	6	2.5	-	-
	2	2	2	3	5	5	5	6	6	2.5
L14	1	14	28	32	40	65	70	100	-	-
	2	10	14	28	32	40	65	70	70	100
L15	1	10	19	22	28	36	42	42	-	-
	2	9	10	19	22	28	36	42	42	42
B1 h9	1	4	6	8	10	14	16	18	-	-
	2	3	4	6	8	10	14	16	16	18
H1	1	13.5	24.5	31	41	48.5	59	64	-	-
	2	11.2	13.5	24.5	31	41	48.5	59	59	64

Performance - AHS (Input Shaft as Option)

Model No.		Stage	Ratio ⁽¹⁾	AHS064	AHS090	AHS110	AHS140	AHS200	AHS255	AHS285	AHS355	AHS450
Max. Radial Load $F_{1rB}^{(2)}$	N	1	4~10	460	600	800	1,025	2,720	2,940	3,620	-	-
		2	16~100	275	460	600	800	1,025	2,720	2,940	3,240	3,620
Max. Axial Load $F_{1aB}^{(2)}$	N	1	4~10	230	300	400	512	1,360	1,470	1,810	-	-
		2	16~100	137	230	300	400	512	1,360	1,470	1,620	1,810
Moment of Inertia	Kg·cm ²	1	4~10	0.19	0.62	1.78	7.72	44.73	55.41	133.12	-	-
		2	16~100	0.06	0.19	0.62	1.78	7.72	44.73	53.41	133.12	111.15

(1) Ratio ($i = N_{in} / N_{out}$).

(2) Applied to the input shaft center at 1000 rpm

(3) The customization detail please contact with APEX sales.

AHK Gearbox

AHK Structure

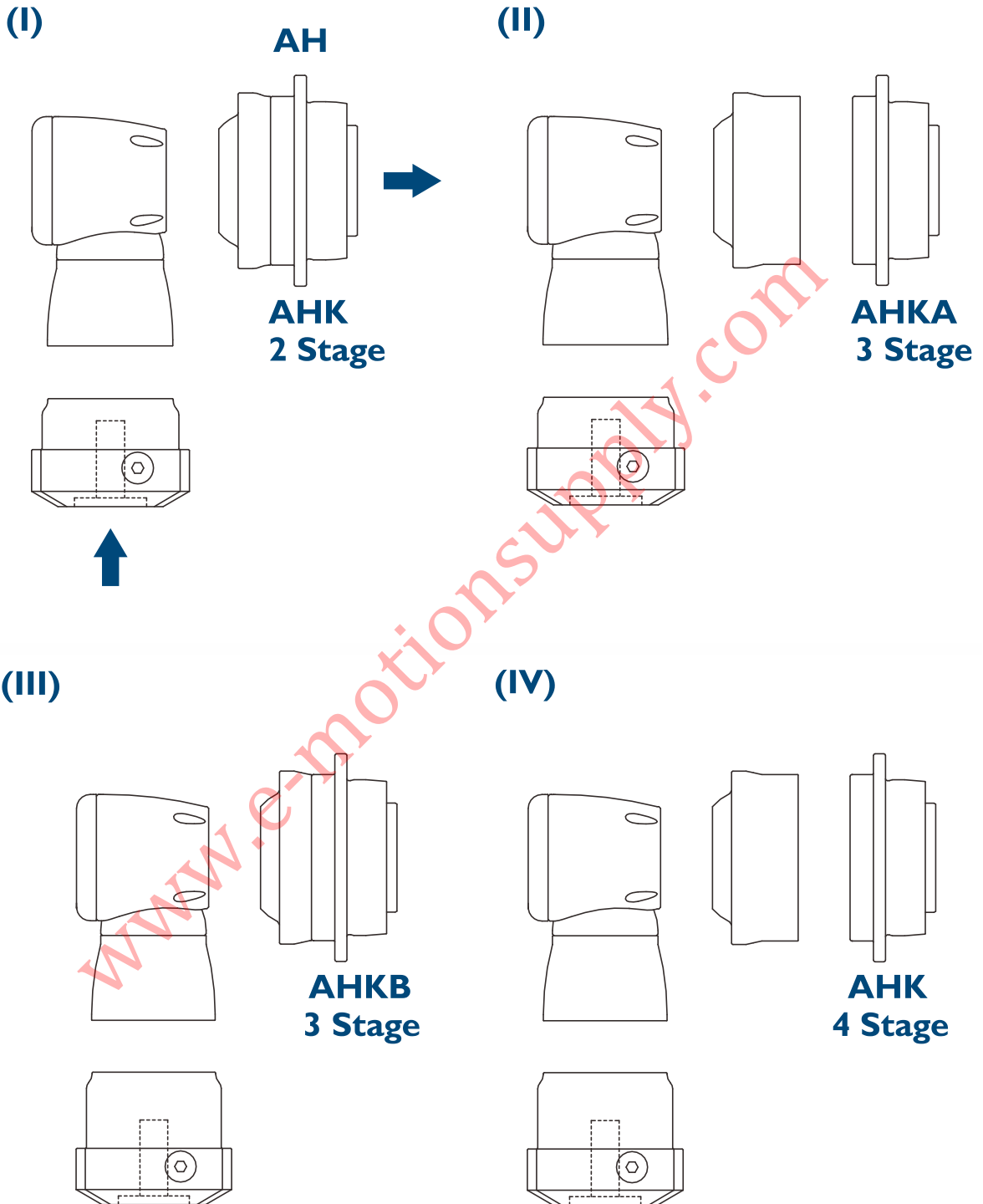

Performance - AHK (2 Stage) Gearbox

Model No.	Stage	Ratio ⁽¹⁾	AHK064	AHK090	AHK110	AHK140	AHK200	AHK255	AHK285	AHK355	
Nominal Output Torque T_{2N} By n_{IN}	Nm	2	12	100	200	400	805	1,495	-	-	-
			15	-	-	-	-	-	2,005	3,675	6,510
			16	100	225	405	815	1,510	-	-	-
			20	100	230	405	820	1,520	1,780	3,710	6,570
			25	95	195	350	710	1,320	1,775	3,735	6,615
			28	92	200	400	800	1,535	-	-	-
			35	95	200	355	715	1,330	1,950	3,750	6,675
			40	72	160	340	680	1,440	-	-	-
			49	63	135	290	585	1,105	1,680	2,685	5,470
			50	90	200	360	725	1,345	1,800	3,000	5,500
70	60	130	250	440	990	1,510	2,550	4,820			
100	24	57	160	350	655	1,005	1,685	3,315			
Emergency Stop Torque T_{2NOT}	Nm	2	12~100	2 times T_{2N}							
Max. Acceleration Torque T_{2B}	Nm	2	12~100	1.5 times T_{2N}							
No Load Running Torque ⁽³⁾	Nm	2	12~100	1	1.3	2	3.1	6	13	16	20
Backlash ⁽²⁾	arcmin	2	12~100	≤ 3	≤ 2	≤ 2	≤ 2	≤ 2	≤ 2	≤ 2	≤ 2
Torsional Rigidity	Nm/arcmin	2	12~100	12	27	56	112	389	642	1,275	2,500
Nominal Input Speed n_{IN}	rpm	2	12~100	3,000	3,000	2,800	2,700	2,200	2,100	2,000	1,600
Max. Input Speed n_{IB}	rpm	2	12~100	6,000	6,000	6,000	4,500	4,500	4,000	3,000	2,500
Max. Axial Load F_{2a} ⁽⁴⁾	N	2	12~100	1,690	2,220	4,070	8,530	17,000	26,900	39,200	101,500
Max. Tilting Moment M_{2k} ⁽⁴⁾	Nm	2	12~100	120	280	480	1,310	3,530	5,920	9,230	29,100
Operating Temp	°C	2	12~100	-10° C ~ 90° C							
Degree of Gearbox Protection		2	12~100	IP67							
Lubrication		2	12~100	Synthetic lubrication grease							
Mounting Position		2	12~100	All directions							
Running Noise ⁽³⁾	dB(A)	2	12~100	≤ 64	≤ 66	≤ 68	≤ 68	≤ 70	≤ 70	≤ 72	≤ 74
Efficiency η	%	2	12~100	≥ 94%							

(1) Ratio ($i = N_{in} / N_{out}$).

(2) Backlash is measured at 2% of Nominal Output Torque T_{2N} .

(3) The dB values are measured by gearbox with ratio 100 (2-stage), no loading at 3,000 RPM or at the respective Nominal Input Speed by bigger model size.

By lower ratio and/or higher RPM, the noise level could be 3 to 5 dB higher.

(4) Applied to the output flange center at 100 rpm.

(5) Continuous operation is not recommended.

Inertia - AHK (2 Stage) Gearbox

Model No.	AHK064	AHK090	AHK110	AHK140	AHK200	AHK255	AHK285	AHK355
8	0.1	-	-	-	-	-	-	-
11	0.17	0.18	-	-	-	-	-	-
14	0.21	0.5	0.52	-	-	-	-	-
19	-	0.65	1.69	1.71	-	-	-	-
24	-	-	4.89	5.05	6.92	-	-	-
28	-	-	-	6.55	6.98	-	-	-
32	-	-	-	9.47	10.18	10.18	-	-
35	-	-	-	14.91	15.21	15.21	15.68	-
38	-	-	-	20.69	20.7	20.7	21.69	23.46
42	-	-	-	-	22.83	22.83	23.59	25.28
48	-	-	-	-	58.45	58.45	59.3	61.61
55	-	-	-	-	-	-	-	89.67

(A) \varnothing = Input shaft diameter.

Dimension AHK (2 stage) Gearbox (Ratio i=12~100)

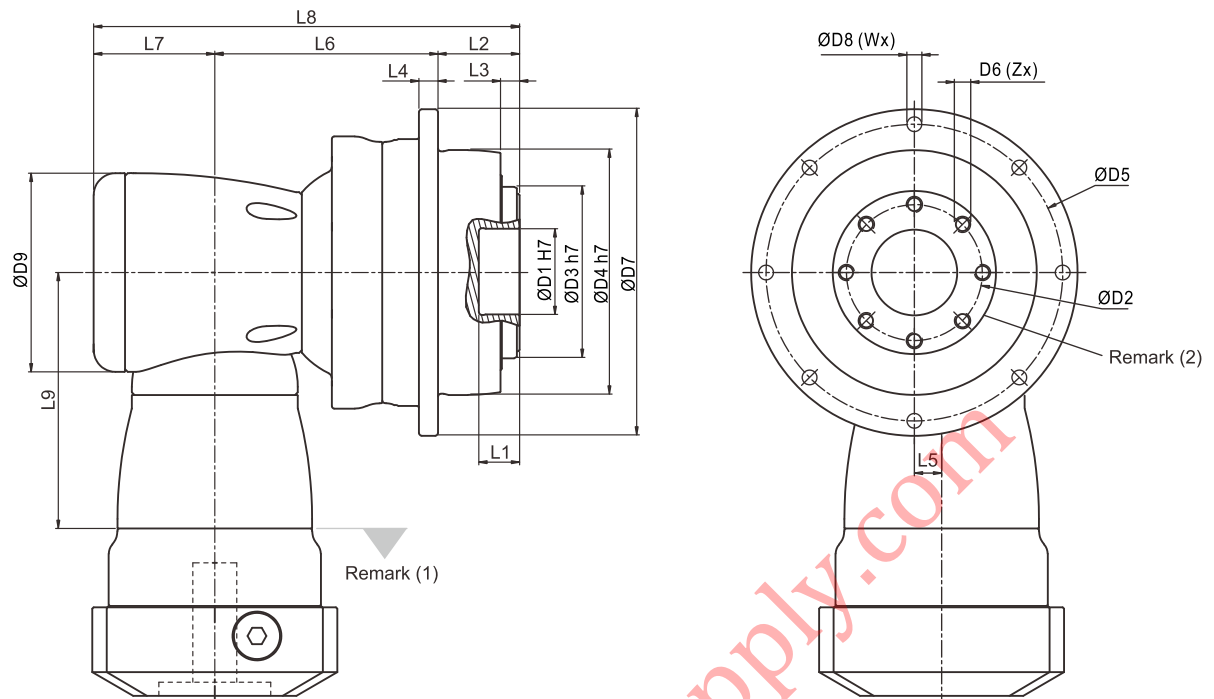

Dimension	AHK064	AHK090	AHK110	AHK140	AHK200	AHK255	AHK285	AHK355
D1 H7	20	31.5	40	50	80	100	100	120
D2	31.5	50	63	80	125	140	160	200
D3 h7	40	63	80	100	160	180	200	250
D4 h7	64	90	110	140	200	255	285	355
D5	79	109	135	168	233	280	310	385
D6 x Pitch x Deep	M5x0.8Px8	M6x1Px10	M6x1Px11	M8x1.25Px15	M10x1.5Px20	M16x2Px25	M20x2.5Px31	M24x3Px32
D7	88	120	147	180	249.5	302	332	415
D8	4.5	5.5	5.5	6.6	9	13.5	13.5	17.5
D9	73	94	116	163	210	210	255	300
L1	8	15	15	15	16	16	16	35
L2	19.5	30	29	38	50	66	75	80
L3	4	7	7	7.5	8.5	13.5	16.5	20
L4	5	7	8	10	12	18	20	45
L5	10	13	17	25	31	31	36	43
L6	87	90.5	114	147.5	175	191.5	249.5	290
L7	44.5	53	68.3	89	115	115	131	165
L8	151	173.5	211.3	274.5	340	372.5	455.5	535
L9	94	114.5	129	173.5	228	228	265.5	294.5
X in Degree	45	45	22.5	30	30	24	24	22.5
Y in Degree	45	45	22.5	30	30	24	24	22.5
Z	8	8	12	12	12	12	12	16
U in Degree	45	45	45	30	30	22.5	22.5	30
V in Degree	45	45	45	30	30	22.5	22.5	30
W	8	8	8	12	12	16	16	12

(1) Dimensions are related to motor interface. Please contact APEX for details.

(2) Refer to the AH series (Page 05) for flange interface.

Performance - AHKA (3 stage) Gearbox

Model No.		Stage	Ratio ⁽¹⁾	AHKA285	AHKA355	AHKA450
Nominal Output Torque T_{2N} By n_{1N}	Nm	3	100	3,875	6,815	12,930
			125	3,900	6,855	12,995
			140	3,910	6,870	13,030
			175	3,930	6,910	13,090
			200	3,945	6,930	12,000
			250	3,970	6,970	13,195
			350	4,000	7,030	13,150
			500	4,035	5,350	9,050
			700	3,090	6,190	11,960
			1,000	1,770	3,400	7,055
Emergency Stop Torque T_{2NOT}	Nm	3	100~1,000	2 times T_{2N}		
Max. Acceleration Torque T_{2B}	Nm	3	100~1,000	1.5 times T_{2N}		
No Load Running Torque ⁽³⁾	Nm	3	100~1,000	6	6	13
Backlash ⁽²⁾	arcmin	3	100~1,000	≤ 2	≤ 2	≤ 2
Torsional Rigidity	Nm/arcmin	3	100~1,000	1,275	2,500	5,100
Nominal Input Speed n_{1N}	rpm	3	100~1,000	2,100	2,100	2,000
Max. Input Speed n_{1B}	rpm	3	100~1,000	4,000	4,000	3,000
Max. Axial Load F_{2a} ⁽⁴⁾	N	3	100~1,000	39,200	101,500	143,700
Max. Tilting Moment M_{2K} ⁽⁴⁾	Nm	3	100~1,000	9,230	29,100	63,300
Operating Temp	°C	3	100~1,000	-10° C ~ 90° C		
Degree of Gearbox Protection		3	100~1,000	IP65		
Lubrication		3	100~1,000	Synthetic lubrication grease		
Mounting Position		3	100~1,000	All directions		
Running Noise ⁽³⁾	dB(A)	3	100~1,000	≤ 72	≤ 74	≤ 76
Efficiency η	%	3	100~1,000	$\geq 92\%$		

(1) Ratio ($i = N_{in} / N_{out}$).

(2) Backlash is measured at 2% of Nominal Output Torque T_{2N} .

(3) The dB values are measured by gearbox with ratio 1,000 (3-stage), no loading at 3,000 RPM or at the respective Nominal Input Speed by bigger model size.

By lower ratio and/or higher RPM, the noise level could be 3 to 5 dB higher.

(4) Applied to the output flange center at 100 rpm.

(5) Continuous operation is not recommended.

Inertia - AHKA (3 stage) Gearbox

Model No.		AHKA285	AHKA355	AHKA450
Input Shaft (C3) $\varnothing^{(A)}$				
32	kg.cm ²	10.18	10.18	-
35		15.21	15.21	15.68
38		20.7	20.7	21.69
42		22.83	22.83	23.59
48		58.45	58.45	59.3
55		-	-	86.95

(A) \varnothing = Input shaft diameter.

Dimension AHKA (3 Stage) Gearbox (Ratio $i = 100 \sim 1,000$)

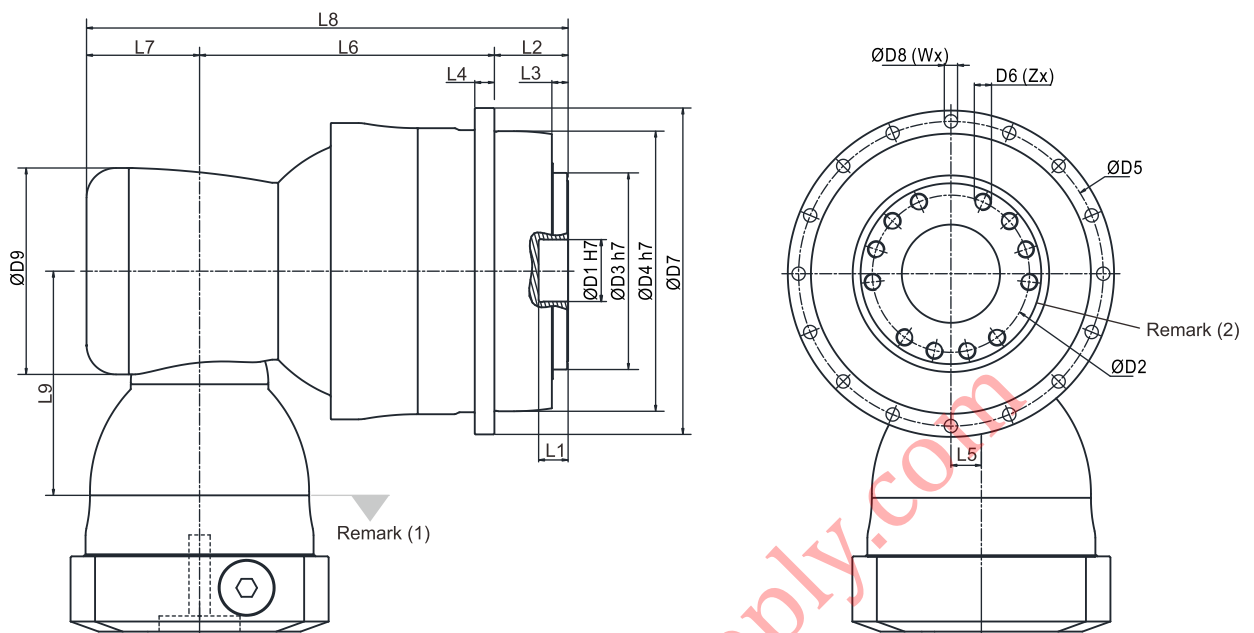

Dimension	AHKA285	AHKA355	AHKA450
D1 H7	100	120	155
D2	160	200	250
D3 h7	200	250	315
D4 h7	285	355	450
D5	310	385	490
D6 x Pitch x Deep	M20x2.5Px31	M24x3Px32	M30x3.5Px40
D7	332	415	530
D8	13.5	17.5	22
D9	210	210	255
L1	16	35	24
L2	75	80	85
L3	16.5	20	20
L4	20	45	60
L5	31	31	36
L6	300	332	447.5
L7	115	115	131
L8	490	527	663.5
L9	228	228	265.5
X in Degree	24	22.5	30
Y in Degree	24	22.5	30
Z	12	16	12
U in Degree	22.5	30	30
V in Degree	22.5	30	30
W	16	12	12

(1) Dimensions are related to motor interface. Please contact APEX for details.

(2) Refer to the AH series (Page 05) for flange interface.

Performance - AHKB (3 stage) Gearbox

Model No.	Stage	Ratio ⁽¹⁾	AHKB090	AHKB110	AHKB140	AHKB200	AHKB255	AHKB285	AHKB355	
Nominal Output Torque T_{2N} By n_{1N}	Nm	3	64	205	415	840	1,545	-	-	-
			84	200	420	845	1,555	-	-	-
			100	205	420	845	1,565	2,085	3,830	6,745
			125	200	365	730	1,355	2,095	3,850	6,785
			140	205	425	845	1,580	1,750	3,860	6,805
			175	205	365	740	1,370	2,115	3,885	6,845
			200	205	430	845	1,590	1,780	3,900	6,865
			250	205	370	745	1,380	2,135	3,920	6,905
			280	200	400	800	1,560	1,780	-	-
			350	210	375	755	1,395	1,950	3,750	6,965
			400	160	340	680	1,440	-	-	-
			500	200	380	760	1,405	1,800	3,000	5,500
			700	135	325	670	1,240	1,875	3,005	6,060
			1,000	55	160	380	660	1,065	1,725	3,325
Emergency Stop Torque T_{2NOT}	Nm	3	64~1,000	2 times T_{2N}						
Max. Acceleration Torque T_{2B}	Nm	3	64~1,000	1.5 times T_{2N}						
No Load Running Torque ⁽³⁾	Nm	3	64~1,000	0.2	0.2	0.3	0.4	1	1.2	1.5
Backlash ⁽²⁾	arcmin	3	64~1,000	≤ 2	≤ 2	≤ 2	≤ 2	≤ 2	≤ 2	≤ 2
Torsional Rigidity	Nm/arcmin	3	64~1,000	27	56	112	389	642	1,275	2,500
Nominal Input Speed n_{1N}	rpm	3	64~1,000	5,500	4,600	4,600	4,000	3,700	3,400	3,100
Max. Input Speed n_{1B}	rpm	3	64~1,000	7,000	7,000	7,000	6,000	5,500	5,000	4,500
Max. Axial Load F_{2a} ⁽⁴⁾	N	3	64~1,000	2,220	4,070	8,530	17,000	26,900	39,200	101,500
Max. Tilting Moment M_{2K} ⁽⁴⁾	Nm	3	64~1,000	280	480	1,310	3,530	5,920	9,230	29,100
Operating Temp	°C	3	64~1,000	-10° C ~ 90° C						
Degree of Gearbox Protection		3	64~1,000	IP65						
Lubrication		3	64~1,000	Synthetic lubrication grease						
Mounting Position		3	64~1,000	All directions						
Running Noise ⁽³⁾	dB(A)	3	64~1,000	≤ 66	≤ 68	≤ 68	≤ 70	≤ 70	≤ 72	≤ 74
Efficiency η	%	3	64~1,000	≥ 92%						

(1) Ratio ($i = N_{in} / N_{out}$).

(2) Backlash is measured at 2% of Nominal Output Torque T_{2N} .

(3) The dB values are measured by gearbox with ratio 1,000 (3-stage), no loading at 3,000 RPM or at the respective Nominal Input Speed by bigger model size.

By lower ratio and/or higher RPM, the noise level could be 3 to 5 dB higher.

(4) Applied to the output flange center at 100 rpm.

(5) Continuous operation is not recommended.

Inertia - AHKB (3 stage) Gearbox

Model No.	AHKB090	AHKB110	AHKB140	AHKB200	AHKB255	AHKB285	AHKB355
8	0.17	-	-	-	-	-	-
11	0.17	0.52	-	-	-	-	-
14	0.21	0.53	1.83	-	-	-	-
19	-	0.68	1.83	5.6	-	-	-
24	-	-	5.04	5.63	5.63	-	-
28	-	-	-	7.18	7.18	-	-
32	-	-	-	10.1	10.1	12.63	-
35	-	-	-	15.54	15.54	17.75	17.35
38	-	-	-	21.32	21.32	23.26	23.61
42	-	-	-	-	23.2	25.4	25.5
48	-	-	-	-	56.07	61.02	61.22

(A) \emptyset = Input shaft diameter.

Dimension AHKB (3 stage) Gearbox (Ratio $i = 64 \sim 1,000$)

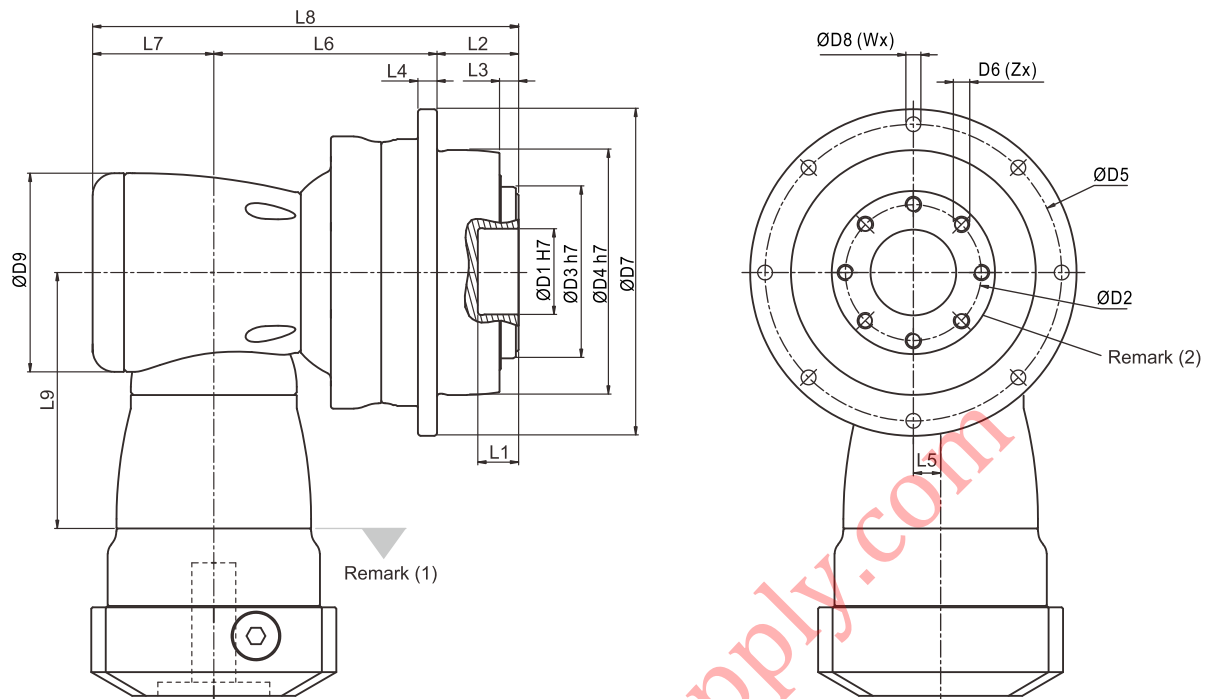

Dimension	AHKB090	AHKB110	AHKB140	AHKB200	AHKB255	AHKB285	AHKB355
D1 H7	31.5	40	50	80	100	100	120
D2	50	63	80	125	140	160	200
D3 h7	63	80	100	160	180	200	250
D4 h7	90	110	140	200	255	285	355
D5	109	135	168	233	280	310	385
D6 x Pitch x Deep	M6x1Px10	M6x1Px11	M8x1.25Px15	M10x1.5Px20	M16x2Px25	M20x2.5Px31	M24x3Px32
D7	120	147	180	249.5	302	332	415
D8	5.5	5.5	6.6	9	13.5	13.5	17.5
D9	94	116	163	210	210	255	300
L1	15	15	15	16	16	16	35
L2	30	29	38	50	66	75	80
L3	7	7	7.5	8.5	13.5	16.5	20
L4	7	8	10	12	18	20	45
L5	13	17	25	31	31	36	43
L6	90.5	114	147.5	175	191.5	249.5	290
L7	53	68.3	89	115	115	131	165
L8	173.5	211.3	274.5	340	372.5	455.5	535
L9	114.5	129	173.5	228	228	265.5	294.5
X in Degree	45	22.5	30	30	24	24	22.5
Y in Degree	45	22.5	30	30	24	24	22.5
Z	8	12	12	12	12	12	16
U in Degree	45	45	30	30	22.5	22.5	30
V in Degree	45	45	30	30	22.5	22.5	30
W	8	8	12	12	16	16	12

(1) Dimensions are related to motor interface. Please contact APEX for details.

(2) Refer to the AH series (Page 05) for flange interface.

Performance - AHK (4 Stage) Gearbox

Model No.		Stage	Ratio ⁽¹⁾	AHK285	AHK355	AHK450
Nominal Output Torque T_{2N} By n_{1N}	Nm	4	1,225	4,070	7,145	13,490
			1,400	4,085	7,170	13,535
			1,750	4,100	7,200	13,585
			2,000	4,120	7,200	12,000
			2,800	3,185	6,320	12,145
			3,500	4,180	7,330	13,150
			5,000	4,285	5,350	9,050
			7,000	3,445	6,780	12,670
			10,000	2,240	4,425	9,370
Emergency Stop Torque T_{2NOT}	Nm	4	1,225~10,000	2 times T_{2N}		
Max. Acceleration Torque T_{2B}	Nm	4	1,225~10,000	1.5 times T_{2N}		
No Load Running Torque ⁽³⁾	Nm	4	1,225~10,000	0.4	0.4	1
Backlash ⁽²⁾	arcmin	4	1,225~10,000	≤ 2	≤ 2	≤ 2
Torsional Rigidity	Nm/arcmin	4	1,225~10,000	1,275	2,500	5,100
Nominal Input Speed n_{1N}	rpm	4	1,225~10,000	3,700	3,700	3,400
Max. Input Speed n_{1B}	rpm	4	1,225~10,000	5,500	5,500	5,000
Max. Axial Load F_{2a} ⁽⁴⁾	N	4	1,225~10,000	39,200	101,500	143,700
Max. Tilting Moment M_{2K} ⁽⁴⁾	Nm	4	1,225~10,000	9,230	29,100	63,300
Operating Temp	°C	4	1,225~10,000	-10° C ~ 90° C		
Degree of Gearbox Protection		4	1,225~10,000	IP65		
Lubrication		4	1,225~10,000	Synthetic lubrication grease		
Mounting Position		4	1,225~10,000	All directions		
Running Noise ⁽³⁾	dB(A)	4	1,225~10,000	≤ 72	≤ 74	≤ 76
Efficiency η	%	4	1,225~10,000	$\geq 90\%$		

(1) Ratio ($i = N_{in} / N_{out}$).

(2) Backlash is measured at 2% of Nominal Output Torque T_{2N} .

(3) The dB values are measured by gearbox with ratio 10,000 (4-stage), no loading at 3,000 RPM or at the respective Nominal Input Speed by bigger model size.

By lower ratio and/or higher RPM, the noise level could be 3 to 5 dB higher.

(4) Applied to the output flange center at 100 rpm.

(5) Continuous operation is not recommended.

Inertia - AHK (4 Stage) Gearbox

Model No.		AHK285	AHK355	AHK450
Input Shaft (C3) $\varnothing^{(A)}$				
24	kg.cm ²	5.63	5.63	-
28		7.18	7.18	-
32		10.1	10.1	12.63
35		15.54	15.54	17.75
38		21.32	21.32	23.26

(A) \varnothing = Input shaft diameter.

Dimension AHK (4 Stage) Gearbox (Ratio i = 1,225~10,000)

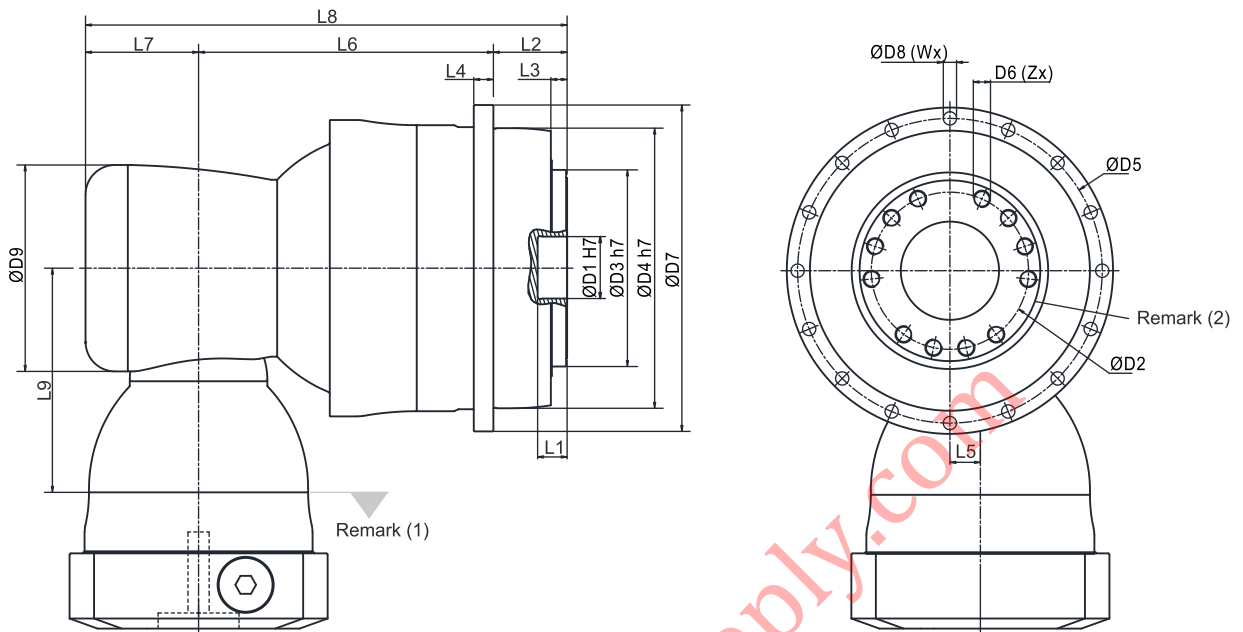

Dimension	AHK285	AHK355	AHK450
D1 H7	100	120	155
D2	160	200	250
D3 h7	200	250	315
D4 h7	285	355	450
D5	310	385	490
D6 x Pitch x Deep	M20x2.5Px31	M24x3Px32	M30x3.5Px40
D7	332	415	530
D8	13.5	17.5	22
D9	210	210	255
L1	16	35	24
L2	75	80	85
L3	16.5	20	20
L4	20	45	60
L5	31	31	36
L6	300	332	447.5
L7	115	115	131
L8	490	527	663.5
L9	228	228	265.5
X in Degree	24	22.5	30
Y in Degree	24	22.5	30
Z	12	16	12
U in Degree	22.5	30	30
V in Degree	22.5	30	30
W	16	12	12

(1) Dimensions are related to motor interface. Please contact APEX for details.

(2) Refer to the AH series (Page 05) for flange interface.

Performance AHKC Gearbox

Model No.	Stage	Ratio ⁽¹⁾	AHKC064	AHKC090	AHKC110	AHKC140	AHKC200	AHKC255	AHKC285	AHKC355	AHKC450	
Nominal Output Torque T_{2N} By n_{1N}	2	4	100	205	380	775	1,440	2,240	4,160	-	-	
		5	85	185	330	670	1,250	1,930	3,610	-	-	
		7	60	135	260	525	1,000	1,750	2,535	-	-	
		8	96	205	395	800	1,320	-	-	-	-	
	3	10	90	165	340	690	1,290	2,000	3,700	-	-	
		21	-	195	345	700	1,310	2,100	3,750	6,590	12,630	
		31	-	135	275	565	1,070	1,790	2,660	5,720	10,800	
		46	-	57	160	340	675	1,080	1,890	3,460	7,800	
3	61	-	135	285	590	1,115	1,790	2,750	5,720	11,110		
	91	-	57	160	350	675	985	1,600	3,460	6,430		
Emergency Stop Torque T_{2NOT}	Nm	2,3	4~91	2 times T_{2N}								
Max. Acceleration Torque T_{2B}	Nm	2,3	4~91	1.5 times T_{2N}								
No Load Running Torque ⁽³⁾	Nm	2	4~10	2	2.5	5.8	12	25	48	95	-	-
		3	21~91	1	1.5	2.5	4	9	18.5	35	75	148
Backlash ⁽²⁾	arcmin	2	4~10	≤ 3	≤ 2	≤ 2	≤ 2	≤ 2	≤ 2	≤ 2	-	-
		3	21~91	-	≤ 2	≤ 2	≤ 2	≤ 2	≤ 2	≤ 2	≤ 2	≤ 2
Torsional Rigidity	Nm/arcmin	2,3	4~91	12	27	56	112	389	642	1,275	2,500	5,100
Nominal Input Speed n_{1N}	rpm	2	4~10	5,000	3,600	3,000	2,300	1,800	1,500	1,100	-	-
		3	21~91	-	4,600	4,000	3,000	2,300	1,800	1,500	1,500	1,100
Max. Input Speed n_{1B}	rpm	2	4~10	7,000	6,000	5,500	4,500	3,500	3,000	2,200	-	-
		3	21~91	-	7,000	6,500	5,500	4,500	3,500	3,000	3,000	2,200
Max. Axial Load F_{2a} ⁽⁴⁾	N	2,3	4~91	1,690	2,220	4,070	8,530	17,000	26,900	39,200	101,500	143,700
Max. Tilting Moment M_{2K} ⁽⁴⁾	Nm	2,3	4~91	120	280	480	1,310	3,530	5,920	9,230	29,100	63,300
Operating Temp	°C	2,3	4~91	-10° C ~ 90° C								
Degree of Gearbox Protection		2,3	4~91	IP65								
Lubrication		2,3	4~91	Synthetic lubrication grease								
Mounting Position		2,3	4~91	All directions								
Running Noise ⁽³⁾	dB(A)	2	4~10	≤ 68	≤ 68	≤ 68	≤ 70	≤ 70	≤ 72	≤ 74	-	-
		3	21~91	-	≤ 68	≤ 68	≤ 70	≤ 70	≤ 72	≤ 74	≤ 74	≤ 76
Efficiency η	%	2	4~10	≥ 95%								
		3	21~91	≥ 93%								

(1) Ratio ($i = N_{in} / N_{out}$).

(2) Backlash is measured at 2% of Nominal Output Torque T_{2N} .

(3) The dB values are measured by gearbox with ratio 10 (2-stage) or ratio 91 (3-stage), no loading at 3,000 RPM or at the respective Nominal Input Speed by bigger model size.

By lower ratio and/or higher RPM, the noise level could be 3 to 5 dB higher.

(4) Applied to the output flange center at 100 rpm.

(5) Continuous operation is not recommended.

Inertia AHKC Gearbox (Ratio $i = 4 \sim 10 / 21 \sim 91$)

Model No.	AHKC064	AHKC090	AHKC110	AHKC140	AHKC200	AHKC255	AHKC285	AHKC355	AHKC450						
$\emptyset^{(A)}$ (C3)	2-st.	2-st.	3-st.	2-st.	3-st.	2-st.	3-st.	2-st.	3-st.	2-st.	3-st.	2-st.	3-st.	3-st.	3-st.
8	0.1	-	0.1	-	-	-	-	-	-	-	-	-	-	-	-
11	0.17	0.52	0.17	-	-	-	-	-	-	-	-	-	-	-	-
14	0.21	0.52	0.21	-	0.52	-	-	-	-	-	-	-	-	-	-
19	0.62	1.69	0.62	1.71	1.69	-	1.71	-	-	-	-	-	-	-	-
24	-	4.89	-	5.05	4.89	6.92	5.05	-	6.92	-	-	-	-	-	-
28	-	-	-	6.55	-	6.98	6.55	-	6.98	-	-	-	-	-	-
32	-	-	-	9.47	-	10.18	9.47	10.18	10.18	-	10.18	-	-	-	-
35	-	-	-	14.91	-	15.21	14.91	15.21	15.21	15.68	15.21	23.46	15.68	-	-
38	-	-	-	20.69	-	20.7	20.69	20.7	20.7	21.69	20.7	23.46	21.69	21.69	-
42	-	-	-	-	-	22.83	-	22.83	22.83	23.59	22.83	25.28	23.59	23.59	25.28
48	-	-	-	-	-	58.45	-	58.45	58.45	59.3	58.45	61.61	59.3	59.3	61.61
55	-	-	-	-	-	-	-	-	-	86.95	-	89.67	-	86.95	89.67
60	-	-	-	-	-	-	-	-	-	-	-	112.49	-	-	112.49

(A) \emptyset = Input shaft diameter.

Dimension AHKC Gearbox (Ratio $i=4\sim 10 / 21\sim 91$)

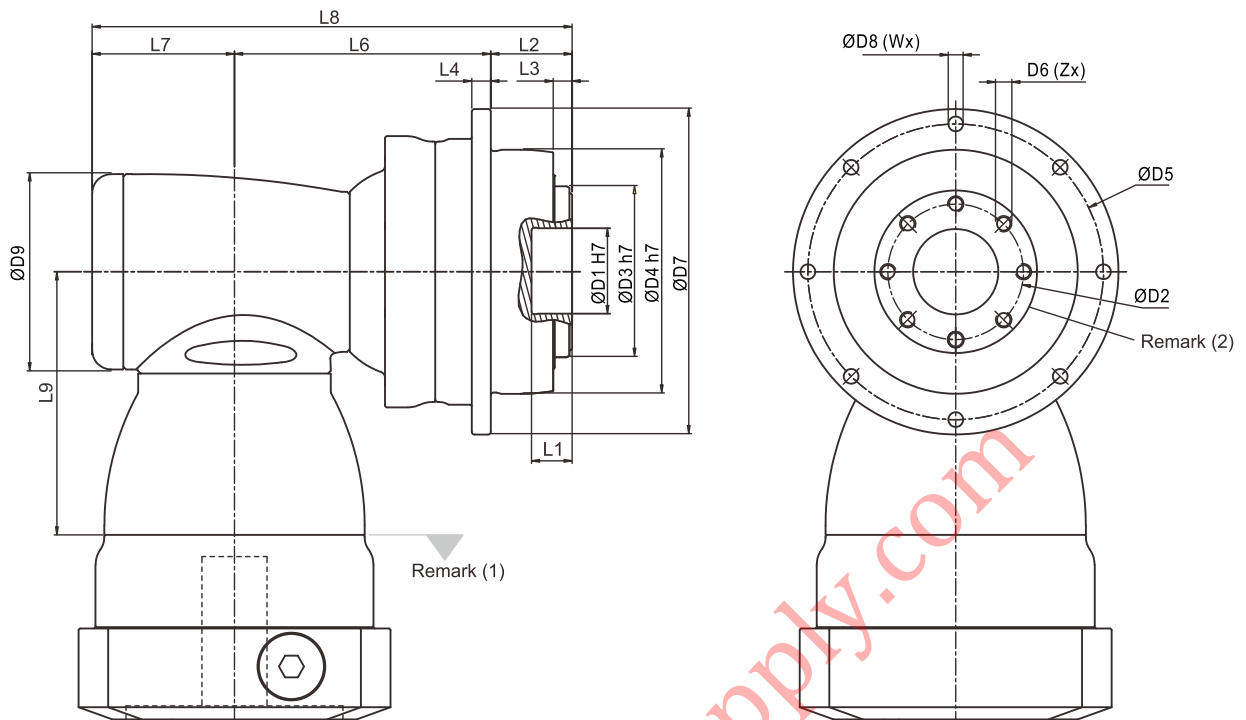

Dimension	AHKC064		AHKC090		AHKC110		AHKC140		AHKC200		AHKC255		AHKC285		AHKC355	AHKC450
	2-st.	3-st.	2-st.	3-st.	2-st.	3-st.	2-st.	3-st.	2-st.	3-st.	2-st.	3-st.	2-st.	3-st.	3-st.	3-st.
D1 H7	20	31.5	40	50	80	100	100	120	155							
D2	31.5	50	63	80	125	140	160	200	250							
D3 h7	40	63	80	100	160	180	200	255	285	355	450					
D4 h7	64	90	110	140	200	255	285	355	450							
D5	79	109	135	168	233	280	310	385	490							
D6 x Pitch x Deep	M5x0.8Px8	M6x1Px10	M6x1Px11	M8x1.25Px15	M10x1.5Px20	M16x2Px25	M20x2.5Px31	M24x3Px32	M30x3.5Px40							
D7	88	120	147	180	249.5	302	332	415	530							
D8	4.5	5.5	5.5	6.6	9	13.5	13.5	17.5	22							
D9	64	92 64	116 92	156 116	156 156	195 156	240 195	195	240							
L1	8	15	15	15	16	16	16	35	24							
L2	19.5	30	29	38	50	66	75	80	85							
L3	4	7	7	7.5	8.5	13.5	16.5	20	20							
L4	5	7	8	10	12	18	20	45	60							
L6	92	100.5 121.5	124.5 142	175.5 174.5	185 244.5	199 264.5	265.5 307.5	339.5	463.5							
L7	46.5	61.5 46.5	76 61.5	97.5 76	97.5 97.5	105.5 97.5	141 105.5	105.5	141							
L8	158	192 198	229.5 232.5	311 288.5	332.5 392	370.5 428	481.5 488	525	689.5							
L9	81.5	113.5 81.5	147.5 113.5	196.5 147.5	196.5 196.5	229 196.5	260 229	229	260							
X in Degree	45	45	22.5	30	30	24	24	22.5	30							
Y in Degree	45	45	22.5	30	30	24	24	22.5	30							
Z	8	8	12	12	12	12	12	16	12							
U in Degree	45	45	45	30	30	22.5	22.5	30	30							
V in Degree	45	45	45	30	30	22.5	22.5	30	30							
W	8	8	8	12	12	16	16	12	12							

(1) Dimensions are related to motor interface. Please contact APEX for details.
 (2) Refer to the AH series (Page 05) for flange interface.

Selection of the optimum gearbox

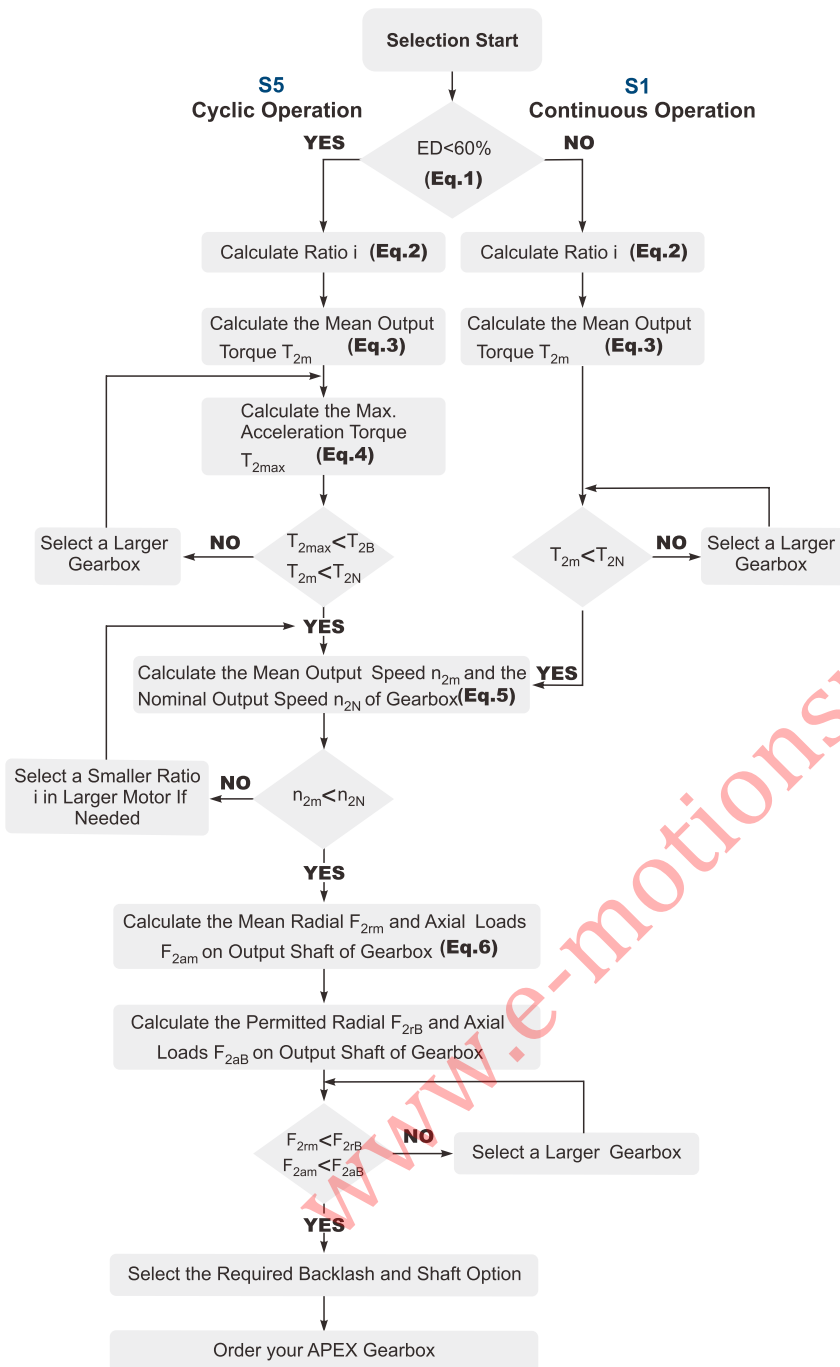

Recommended (for S5 Cycle Operation)

The general design is given for

$$\frac{J_L}{i^2} \leq 4 \times J_m$$

The optimal design is given for

$$\frac{J_L}{i^2} \cong J_m$$

J_L Load Inertia

J_m Motor Inertia

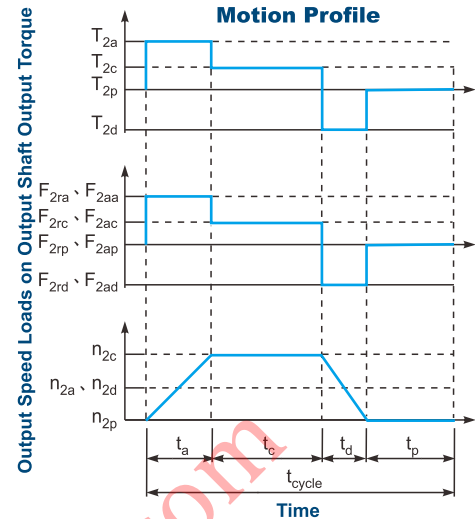

$$1. ED = \frac{t_a + t_c + t_d}{t_{cycle}} \times 100\%$$

Index : a. Acceleration, c. Constant, d. Deceleration, p. Pause

(Eq.1)

$$2. i \cong \frac{n_m}{n_{work}}$$

n_m Output Speed of the Motor

n_{work} Working Speed

(Eq.2)

$$3. T_{2m} = 3 \sqrt{\frac{n_{2a} \times t_a \times T_{2a}^3 + n_{2c} \times t_c \times T_{2c}^3 + n_{2d} \times t_d \times T_{2d}^3}{n_{2a} \times t_a + n_{2c} \times t_c + n_{2d} \times t_d}}$$

(Eq.3)

$$4. T_{2max} = T_{mB} \times i \times K_s \times \eta$$

where K_s is

K_s	No. of Cycles / hr
1.0	0 ~ 1,000
1.1	1,000 ~ 1,500
1.3	1,500 ~ 2,000
1.6	2,000 ~ 3,000
1.8	3,000 ~ 5,000

T_{mB} Max. Output Torque of the Motor

η Efficiency of the Gearbox

(Eq.4)

$$5. n_{2a} = n_{2d} = \frac{1}{2} \times n_{2c}$$

$$n_{2m} = \frac{n_{2a} \times t_a + n_{2c} \times t_c + n_{2d} \times t_d}{t_a + t_c + t_d}$$

$$n_{2N} = \frac{n_{1N}}{i}$$

(Eq.5)

$$6. F_{2rm} = 3 \sqrt{\frac{n_{2a} \times t_a \times F_{2ra}^3 + n_{2c} \times t_c \times F_{2rc}^3 + n_{2d} \times t_d \times F_{2rd}^3}{n_{2a} \times t_a + n_{2c} \times t_c + n_{2d} \times t_d}}$$

$$F_{2am} = 3 \sqrt{\frac{n_{2a} \times t_a \times F_{2aa}^3 + n_{2c} \times t_c \times F_{2ac}^3 + n_{2d} \times t_d \times F_{2ad}^3}{n_{2a} \times t_a + n_{2c} \times t_c + n_{2d} \times t_d}}$$

(Eq.6)

Glossary

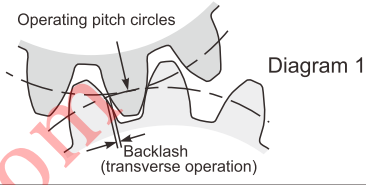
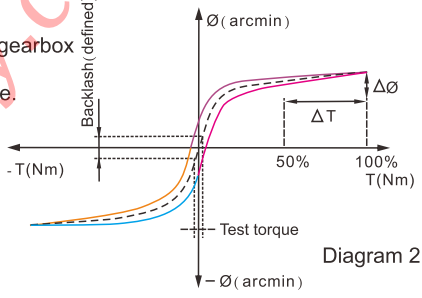
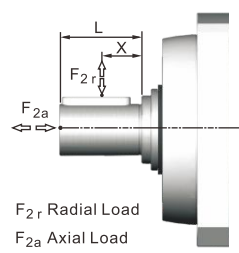
Emergency Stop Torque T_{2NOT}	Nm	The Emergency Stop Torque is the maximum permitted torque at the output of gearbox. This may happen only occasionally and may not exceed 1,000 times during the whole service life.
Max. Acceleration Torque T_{2B}	Nm	Under the Cyclic Operation (S5), the Max. Acceleration Torque is the maximum torque which can be transmitted only briefly to the output of gearbox up to 1,000 cycles/hr.
No Load Running Torque	Nm	The No Load Running Torque is the min. torque to overcome the internal friction of a gearbox without loading*.
Nominal Input Speed n_{1N}	rpm	The Nominal Input Speed is the permitted input speed of gearbox by the Continuous Operation (S1) while the housing temperature does not exceed 90°C. This value is measured at environment temperature 25°C.
Max. Input Speed n_{1B}	rpm	The Max. Input Speed is the max. permitted input speed of gearbox by the Cyclic operation (S5). This value is measured at environment temperature 25°C and serves as the absolute limit of the gearbox.
Backlash	arcmin	<p>The Backlash is the maximum angular measurement between two teeth of gears when the transverse operation occurs (refer to Diagram 1). The arcmin is the measurement unit for the backlash. One arcmin equals 1/60 degree, symbolized as 1'.</p> 
Torsional Rigidity	Nm/arcmin	<p>Torsional Rigidity is the quotient ($\Delta T / \Delta \theta$) between the applied torque and resulting torsion angle. This value indicates how much torque is needed on the gearbox to rotate the output shaft for 1 arcmin. The Torsional Rigidity can be determined by Hysteresis Curve.</p> <p>Hysteresis Curve When the input shaft is locked, increase torque at the output slowly up to T_{2B} in both directions and then release the torque gradually. According to the measured torque and torsion angle, a closed curve will be acquired as in the Diagram 2.</p> 
Radial Load And Axial Load	N	<p>The permitted radial and axial loads on output shaft of the gearbox depend on the design of the gearbox supporting bearings.</p> <p>For more information, please refer to APEX website.</p> 
Efficiency η	%	The transmission efficiency of the gears inside a gearbox (without friction).
Operating Temperature	°C	The Operating Temperature indicates the temperature of gearbox housing.
Degree of Protection		IP code stands for International Protection standard. The IP65 as example: the first IP number stands for protection degree against dust; the second IP number stands for protection against liquid.
Lubrication		APEX uses synthetic lubrication grease. Alternate greases are available, please contact APEX.
Running Noise	dB(A)	The Running Noise is measured depends on gearbox size, the ratio and the speed*. Higher speed usually induces higher noise level, while higher ratio induces lower noise level.
Moment of Inertia J_1	kg.cm ²	The Moment of Inertia J_1 is a measurement of the effort applied to an object to maintain its momentary condition at rest or rotating.
Breakaway Torque	Nm	The Breakaway Torque is the minimum torque to start the rotation from the input side of gearbox. A smaller size or a higher ratio gearbox requests less Breakaway Torque.
Back Driving Torque	Nm	The Back Driving Torque is the minimum torque to start the rotation from the output side of gearbox. A larger size or a higher ratio gearbox requires greater Back Driving Torque.

* This value is measured at environment temperature 25°C and the input speed 3,000 rpm. If the Nominal Input Speed n_{1N} of gearbox is lower than 3,000 rpm, this value is measured by that specific Nominal Input Speed.