



APEX DYNAMICS, INC.

**HIGH TORQUE
HIGH PRECISION
PLANETARY GEARBOX**

**AP / APK
APC / APCK - SERIES**



Gearbox Series - AP / APK / APC / APCK

► Features:

- High Torque
- Optimized Output Torque & Inertia Moment
- High Precision
- Long Service Life
- Low Noise
- Limited Temperature Rise
- Support Flange/Curvic Interface
- Suitable for Rack & Pinion Applications



AP



APC



APK



APCK

Order Code

AP090	—	005.5⁽¹⁾	/	MOTOR
APK090	—	005.5⁽¹⁾	/	MOTOR
				Motor Type
				Ratio
				Gearbox Size

Gearbox Size

AP 090 / 110 / 140 / 200 / 255 / 285 / 355 / 450

APC 090 / 110 / 140 / 200 / 255 / 285 / 355 / 450

APK 090 / 110 / 140 / 200 / 255 / 285 / 355 / 450

APCK 090 / 110 / 140 / 200 / 255 / 285 / 355 / 450

Ratio

AP/APC (1 Stg.) 4 / 5.5

AP/APC (2 Stg.) 16 / 20 / 22 / 27.5 / 28 / 38.5 / 40 / 55

AP/APC (3 Stg.) 64 / 88 / 100 / 110 / 140 / 154 / 160 / 200 / 220 / 280 / 400

APK/APCK (2 Stg.) 4 / 5.5 / 8 / 11

APK/APCK (2 Stg.) 16 / 20 / 22 / 27.5 / 28 / 38.5 / 40 / 55

APK/APCK (3 Stg.) 64 / 88 / 100 / 110 / 137.5 / 140 / 154 / 160 / 200 / 220 / 280 / 385

**APK/APCK (4 Stg.) 400 / 440 / 500 / 550 / 700 / 770 / 1000 / 1078 / 1400 / 1540 / 1600
2000 / 2695 / 2800 / 3850 / 4000 / 5500**

Motor Type : Manufacturer and Model

(1) Ratio ($i = N_{in} / N_{out}$).



©2019 by APEX DYNAMICS, INC.

APEX DYNAMICS, INC. reserves modification and copyrights of all technical specifications, illustrations and drawings in this catalog in allowance for continuous products development and advancement.

For the newest data and information, please visit <http://www.e-motionsupply.com/>

Performance - AP / APC Gearbox

Model No.	Stage	Ratio ⁽¹⁾	AP 090 APC 090	AP 110 APC 110	AP 140 APC 140	AP 200 APC 200	AP 255 APC 255	AP 285 APC 285	AP 355 APC 355	AP 450 APC 450	
Nominal Output Torque T_{2N} By n_{1N}	1	4	205	505	790	1,885	2,920	5,380	-	-	
		5.5	230	435	735	1,635	2,535	4,580	8,300	16,050	
		2	16	300	530	895	1,980	3,055	5,615	-	-
			20	300	535	900	1,995	3,080	5,660	-	-
			22	240	460	770	1,710	2,640	4,755	8,565	16,430
			27.5	240	460	775	1,720	2,660	4,785	8,620	16,530
			28	250	540	910	2,015	3,110	5,720	-	-
			38.5	245	465	785	1,740	2,690	4,830	8,700	16,680
			40	96	225	650	1,610	3,145	5,780	-	-
			55	130	315	795	1,740	2,715	4,875	8,775	16,830
	3	64	310	500	930	2,060	3,180	5,840	-	-	
		88	250	470	800	1,780	2,720	4,920	8,830	16,930	
		100	315	560	945	2,085	3,215	5,910	-	-	
		110	250	475	810	1,790	2,760	4,945	8,875	17,020	
		140	315	565	950	2,105	3,245	5,965	-	-	
		154	250	480	815	1,805	2,785	4,980	8,940	17,150	
		160	210	385	915	2,110	3,255	5,985	-	-	
		200	265	480	960	2,125	3,270	6,020	-	-	
		220	255	480	825	1,820	2,810	5,020	9,010	17,275	
		280	325	575	970	2,140	3,300	6,070	-	-	
400	325	580	980	2,160	3,330	6,120	-	-			
Emergency Stop Torque T_{2NOT}	Nm	1,2,3	4~400								3 times T_{2N}
Max. Acceleration Torque T_{2a}	Nm	1,2,3	4~400								1.5 times T_{2N}
No Load Running Torque ⁽²⁾	Nm	1	4~5.5	1.5	2.5	7.1	14	22	28	42	75
		2	16~55	0.6	1.1	3.7	8	12	18	17	26
		3	64~400	0.35	0.7	1.6	4	4.5	6.5	6	12
Backlash ⁽³⁾	arcmin	1	4~5.5								≤ 1
		2,3	16~400								≤ 2
Torsional Rigidity	Nm/arcmin	1,2,3	4~400	42	95	205	650	1,200	1,800	2,850	5,700
Nominal Input Speed n_{1N}	rpm	1	4~5.5	3,600	3,600	3,000	2,700	2,400	2,100	1,500	1,000
		2	16~55	4,600	4,600	4,000	3,700	3,400	3,100	2,500	2,000
		3	64~400	5,000	5,000	4,600	4,000	3,700	3,400	3,100	2,500
Max. Input Speed n_{1B}	rpm	1	4~5.5	6,000	6,000	5,000	4,500	4,000	3,500	3,000	2,000
		2	16~55	7,000	7,000	6,000	5,500	5,000	4,500	4,000	3,500
		3	64~400	7,000	7,000	7,000	6,000	5,500	5,000	4,500	4,000
Max. Axial Load F_{2a} ⁽⁴⁾	N	1,2,3	4~400	2,220	4,070	8,530	17,000	26,900	39,200	101,500	143,700
Max. Tilting Moment M_{2K} ⁽⁴⁾	Nm	1,2,3	4~400	280	480	1,310	3,530	5,920	9,230	29,100	63,300
Operating Temp.	°C	1,2,3	4~400								-10° C ~ 90° C
Degree of Gearbox Protection		1,2,3	4~400								IP65
Lubrication		1,2,3	4~400								Synthetic lubrication grease
Mounting Position		1,2,3	4~400								All directions
Running Noise ⁽²⁾	dB(A)	1	4~5.5	≤ 59	≤ 64	≤ 66	≤ 66	≤ 68	≤ 68	≤ 68	≤ 70
		2	16~55	≤ 60	≤ 62	≤ 64	≤ 66	≤ 67	≤ 67	≤ 68	≤ 70
		3	64~400	≤ 60	≤ 62	≤ 64	≤ 66	≤ 66	≤ 67	≤ 67	≤ 68
Efficiency η	%	1	4~5.5								≥ 97%
		2	16~55								≥ 94%
		3	64~400								≥ 92%

(1) Ratio ($i = N_{in} / N_{out}$).

(2) The dB values are measured by gearbox with ratio 5.5 (1-stage), 55 (2-stage) or ratio 220 (3-stage), no loading at 3,000 RPM or at the respective Nominal Input Speed by bigger model size.
By lower ratio and/or higher RPM, the noise level could be 3 to 5 dB higher.

(3) Backlash is measured at 2% of Nominal Output Torque T_{2N} .

(4) Applied to the output flange/curvic center at 100 rpm. The calculation formula please refer to Fig. 1.

(5) Continuous operation is not recommended.

$$\text{Max. Tilting Moment } M_{2K} = \frac{F_{2a} * Y + F_{2r} * (X+Z2)}{1000}$$

M_{2K} : [Nm]
 F_{2a}, F_{2r} : [N]
 $X, Y, Z2$: [mm]

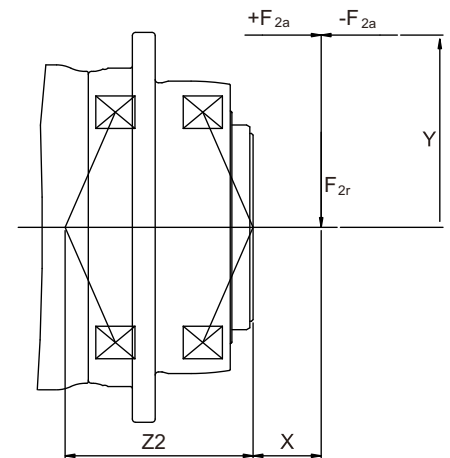

Fig. 1

AP / APK	090	110	140	200	255	285	355	450
Z2 [mm]	84.5	106.2	90	122.8	133.2	175.5	220.6	275.3

Note : Applied to the output flange center at 100 rpm.

Max. Inertia - AP / APC Gearbox

Model No.		AP/APC 090			AP/APC 110			AP/APC 140			AP/APC 200			AP/APC 255		
Ø ^(A)	Stage	1	2	3	1	2	3	1	2	3	1	2	3	1	2	3
11	kg.cm ²	-	-	0.16	-	-	-	-	-	-	-	-	-	-	-	-
14		0.42	0.21	0.19	-	-	0.21	-	-	-	-	-	-	-	-	-
19		0.66	0.6	-	1.84	0.66	0.6	-	-	0.66	-	-	-	-	-	-
24		3.94	-	-	4.11	3.94	-	4.61	4.11	3.94	-	-	4.11	-	-	-
28		-	-	-	5.48	-	-	6.14	5.48	-	-	-	5.48	-	-	6.14
32		-	-	-	7.36	-	-	8.17	7.36	-	-	8.17	7.36	-	-	8.17
35		-	-	-	14.04	-	-	15.54	14.04	-	17.75	15.54	14.04	-	17.75	15.54
38		-	-	-	16.71	-	-	18.19	16.71	-	20.17	18.19	16.71	-	20.17	18.19
42		-	-	-	-	-	-	23.2	-	-	25.4	23.2	-	28.88	25.4	-
48		-	-	-	-	-	-	52.42	-	-	55.18	52.42	-	58.64	55.18	-
55		-	-	-	-	-	-	-	-	-	88.51	-	-	92.48	-	-
60		-	-	-	-	-	-	-	-	-	-	-	-	-	-	-

Model No.		AP/APC 285			AP/APC 355			AP/APC 450		
Ø ^(A)	Stage	1	2	3	I ^(B)	2	3	I ^(B)	2	3
11	kg.cm ²	-	-	-	-	-	-	-	-	-
14		-	-	-	-	-	-	-	-	-
19		-	-	-	-	-	-	-	-	-
24		-	-	-	-	-	-	-	-	-
28		-	-	-	-	-	-	-	-	-
32		-	-	-	-	-	-	-	-	-
35		-	-	17.75	-	-	-	-	-	-
38		-	23.66	20.17	-	-	20.17	-	-	23.66
42		-	28.88	25.4	-	28.79	25.4	-	-	28.95
48		69.78	58.64	55.18	-	92.76	55.18	-	106.06	58.64
55		104.22	92.48	-	-	105.41	-	-	118.67	-
60		127.69	-	-	-	-	-	-	127.37	-

(A) Ø = Input shaft diameter.

(B) For Istage of AP/APC355/450 please contact APEX for details.

Dimension - AP Gearbox

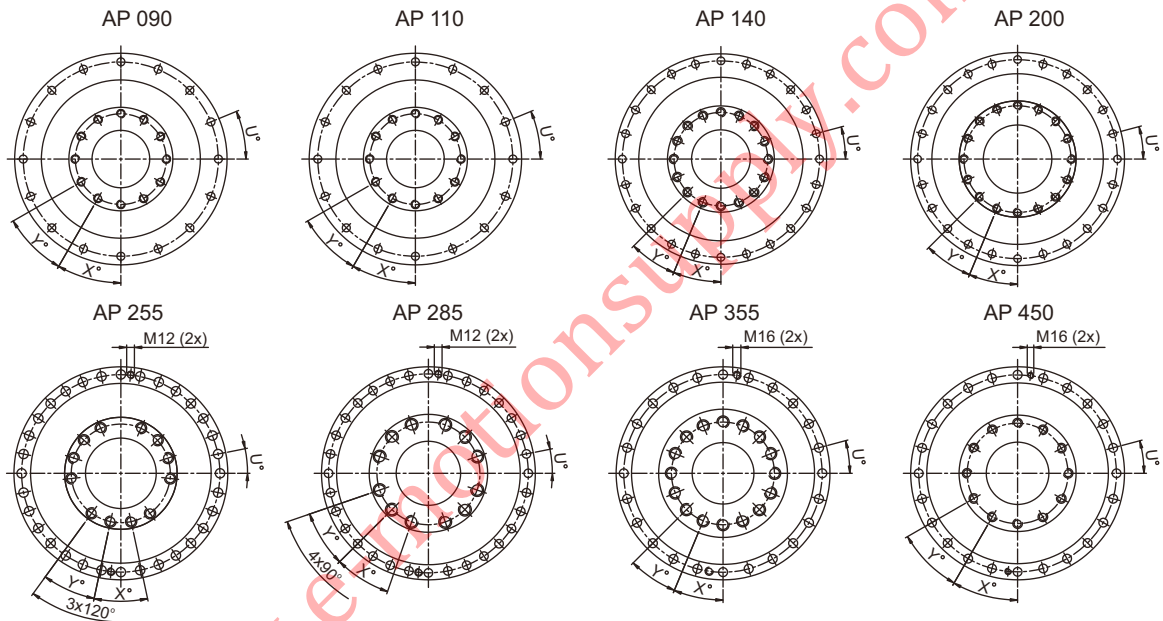
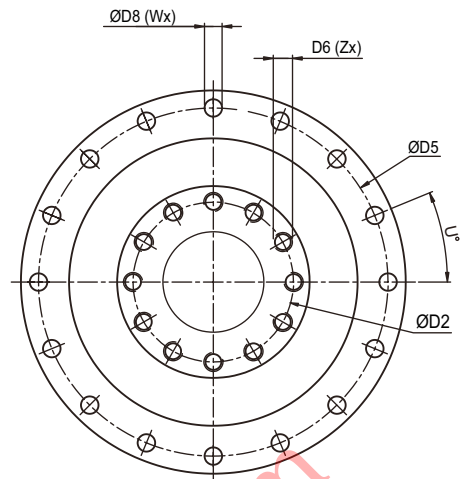
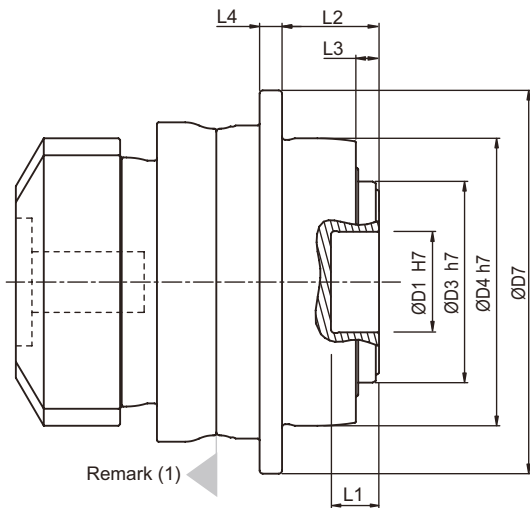

Dimension	AP 090	AP 110	AP 140	AP 200	AP 255	AP 285	AP 355	AP 450
D1 H7	31.5	40	50	80	100	100	120	155
D2	50	63	80	125	140	160	200	250
D3 h7	63	80	100	160	180	200	250	315
D4 h7	90	110	140	200	255	285	355	450
D5	109	135	168	233	280	310	385	490
D6 x Pitch x Deep	M6x1Px11	M8x1.25Px12	M8x1.25Px15	M10x1.5Px20	M16x2Px25	M24x3Px37	M24x3Px32	M30x3.5Px40
D7	120	147	180	249.5	302	332	415	530
D8	5.5	5.5	6.6	9	13.5	13.5	17.5	22
L1	15	15	15	16	16	16	35	24
L2	30	29	38	50	66	75	80	85
L3	7	7	7.5	8.5	13.5	16.5	20	20
L4	7	8	10	12	18	20	45	60
X in Degree	30	30	22.5	22.5	24	26	22.5	30
Y in Degree	30	30	22.5	22.5	24	26	22.5	30
Z	12	12	16	16	12	12	16	12
U in Degree	22.5	22.5	15	15	11.25	11.25	15	15
W	16	16	24	24	32	32	24	24

(I) Dimensions are related to motor interface. Please contact APEX for details.

Dimension - APC Gearbox

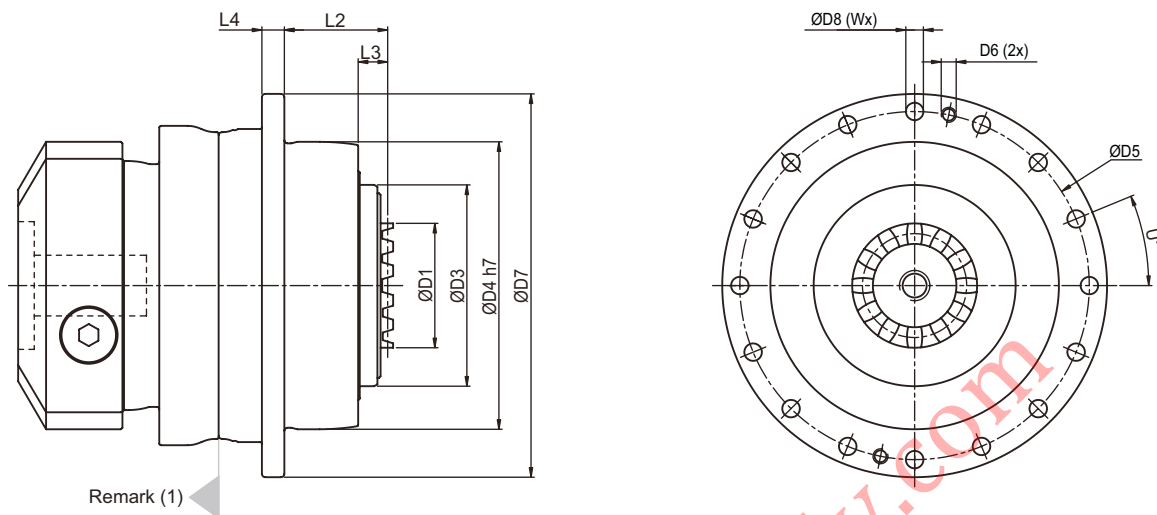

Dimension	APC 090	APC 110	APC 140	APC 200	APC 255	APC 285	APC 355	APC 450
D1	36	46	60	80	90	120	120	132
D3	63	80	100	160	180	200	250	315
D4 h7	90	110	140	200	255	285	355	450
D5	109	135	168	233	280	310	385	490
D6	-	-	-	-	M12	M12	M16	M16
D7	120	147	180	249.5	302	332	415	530
D8	5.5	5.5	6.6	9	13.5	13.5	17.5	22
L2	32.5	31.5	40.5	52.5	68.5	77.5	82.5	87.5
L3	9.5	9.5	10	11	16	19	22.5	22.5
L4	7	8	10	12	18	20	45	60
U in Degree	22.5	22.5	15	15	11.25	11.25	15	15
W	16	16	24	24	32	32	24	24

(1) Dimensions are related to motor interface. Please contact APEX for details.

Performance - APK / APCK Gearbox

Model No.	Stage	Ratio ⁽¹⁾	APK 090 APCK 090	APK 110 APCK 110	APK 140 APCK 140	APK 200 APCK 200	APK 255 APCK 255	APK 285 APCK 285	APK 355 APCK 355	APK 450 APCK 450	
Nominal Output Torque T_{2N} By n_{1N}	2	16	255	528	848	1,800	2,015	3,935	-	-	
		20	255	528	848	1,800	2,015	3,935	-	-	
		22	245	465	780	1,740	2,685	4,815	8,670	-	
		27.5	245	465	785	1,750	2,700	4,840	8,720	-	
		28	240	480	848	1,800	1,872	3,600	-	-	
		38.5	245	470	795	1,770	2,574	4,885	8,795	-	
		40	192	408	816	1,725	1,728	2,880	-	-	
	55	250	475	805	1,785	2,376	3,790	7,260	-		
	3	64	-	565	845	2,080	3,220	5,815	-	-	
		88	-	480	815	1,800	2,185	4,970	8,910	17,020	
		100	-	565	845	2,105	3,260	5,815	-	-	
		110	-	480	820	1,810	2,800	4,990	8,950	17,105	
		137.5	-	480	825	1,820	2,815	5,020	8,995	17,190	
		140	-	565	840	2,125	3,285	5,815	-	-	
		154	-	485	825	1,825	2,820	5,035	8,580	16,500	
		160	-	565	845	2,130	3,295	5,760	-	-	
		200	-	565	845	2,145	3,315	5,815	-	-	
		220	-	490	835	1,840	2,850	5,070	7,920	13,200	
		280	-	540	845	2,160	3,345	5,815	-	-	
	4	385	-	495	850	1,845	2,890	5,130	9,195	17,565	
		400	-	565	845	2,155	3,320	5,815	-	-	
		440	-	450	835	1,840	2,840	5,060	9,070	17,335	
		500	-	565	845	2,165	3,340	5,815	-	-	
		550	-	490	845	1,860	2,870	5,110	9,155	17,485	
		700	-	590	995	2,185	3,370	6,195	-	-	
		770	-	495	850	1,870	2,895	5,150	9,225	17,600	
		1,000	-	565	810	2,205	3,400	5,815	-	-	
		1,078	-	500	860	1,890	2,920	5,180	8,580	16,500	
		1,400	-	540	845	2,220	3,430	5,815	-	-	
		1,540	-	500	870	1,910	2,945	5,220	7,920	13,200	
	1,600	-	565	845	2,225	3,435	5,760	-	-		
	2,000	-	565	810	2,240	3,455	5,815	-	-		
	2,695	-	510	880	1,935	2,980	5,275	9,440	18,015		
2,800	-	540	845	2,225	3,480	5,815	-	-			
3,850	-	510	980	1,610	2,995	5,365	9,585	18,245			
4,000	-	225	650	1,840	3,515	5,815	-	-			
5,500	-	315	895	1,980	3,110	5,515	9,825	18,715			
Emergency Stop Torque T_{2NOT}	Nm	2,3,4	2 times T_{2N}								
Max. Acceleration Torque T_{2B}	Nm	2,3,4	1.5 times T_{2N}								
No Load Running Torque ⁽²⁾	Nm	2	16~55	1.3	2	3.1	6	13	16	20	-
		3	64~385	-	1.4	2.4	4.6	7	8.5	10.5	13
		4	400~5,500	-	0.2	0.3	0.6	0.9	1.2	1.8	2.5
Backlash ⁽³⁾	arcmin	2,3,4	≤ 2								
Torsional Rigidity	Nm/arcmin	2	16~55	27	56	112	389	642	1,275	2,500	-
		3	64~385	-	56	112	389	642	1,275	2,500	5,100
		4	400~5,500	-	45	85	310	535	1,050	1,700	2,700
Nominal Input Speed n_{1N}	rpm	2	16~55	3,000	2,800	2,700	2,200	2,100	2,000	1,600	-
		3	64~385	-	3,000	2,800	2,700	2,200	2,100	2,100	2,000
		4	400~5,500	-	5,500	4,600	4,600	4,000	3,700	3,700	3,400
Max. Input Speed n_{1B}	rpm	2	16~55	6,000	6,000	4,500	4,500	4,000	3,000	2,500	-
		3	64~385	-	6,000	6,000	4,500	4,500	4,000	4,000	3,000
		4	400~5,500	-	7,000	7,000	7,000	6,000	5,500	5,500	5,000
Max. Axial Load F_{2a} ⁽⁴⁾	N	2,3,4	16~5,500	2,220	4,070	8,530	17,000	26,900	39,200	101,500	143,700
Max. Tilting Moment M_{2k} ⁽⁴⁾	Nm	2,3,4	16~5,500	280	480	1,310	3,530	5,920	9,230	29,100	63,300
Operating Temp.	°C	2,3,4	-10° C~ 90° C								
Degree of Gearbox Protection		2,3,4	IP65								
Lubrication		2,3,4	Synthetic lubrication grease								
Mounting Position		2,3,4	All directions								
Running Noise ⁽²⁾	dB(A)	2,3,4	16~5,500	≤ 68	≤ 68	≤ 68	≤ 70	≤ 70	≤ 72	≤ 74	≤ 76
Efficiency η	%	2	16~55	≥ 94%							
		3	64~385	≥ 92%							
		4	400~5,500	≥ 90%							

(1) Ratio ($i = N_{in} / N_{out}$).

(2) The dB values are measured by gearbox with ratio 55 (2-stage), 385 (3-stage) or ratio 5,500 (4-stage), no loading at 3,000 RPM or at the respective Nominal Input Speed by bigger model size.

By lower ratio and/or higher RPM, the noise level could be 3 to 5 dB higher.

(3) Backlash is measured at 2% of Nominal Output Torque T_{2N} .

(4) Applied to the output flange/curvic center at 100 rpm. The calculation formula please refer to page (3)

(5) Continuous operation is not recommended.

Max. Inertia - APK / APCK Gearbox

Model No.		APK/APCK 090			APK/APCK 110			APK/APCK 140			APK/APCK 200			APK/APCK 255			APK/APCK 285				
Ø ^(A)	Stage	2	3	4	2	3	4	2	3	4	2	3	4	2	3	4	2	3	4		
8	kg.cm ²	-	-	0.17	-	-	-	-	-	-	-	-	-	-	-	-	-	-	-		
11		-	-	0.17	-	-	-	-	-	-	-	-	-	-	-	-	-	-	-		
14		0.37	-	0.37	-	-	0.42	-	-	-	-	-	-	-	-	-	-	-	-		
19		0.6	1.61	0.6	-	-	1.61	0.66	-	-	1.83	-	-	-	-	-	-	-	-		
24		-	3.9	-	-	4.01	3.9	3.94	-	4.01	4.11	-	-	4.61	-	-	-	-	-		
28		-	-	-	-	5.53	5.15	-	-	5.53	-	-	5.61	6.14	-	-	-	-	-		
32		-	-	-	-	7.57	-	-	-	8.11	7.57	-	-	8.11	8.17	-	-	-	-		
35		-	-	-	-	14.95	-	-	-	15.32	14.95	-	-	15.32	15.32	15.54	-	-	15.32	15.54	
38		-	-	-	-	17.58	-	-	-	17.72	17.58	-	-	17.72	17.72	18.19	-	-	18.52	17.72	18.19
42		-	-	-	-	-	-	-	-	22.95	-	-	-	22.95	-	-	-	-	23.74	22.95	23.2
48		-	-	-	-	-	-	-	-	52.74	-	-	-	52.74	-	-	-	-	53.49	52.74	52.42
55		-	-	-	-	-	-	-	-	-	-	-	-	-	-	-	-	-	87.34	-	-

Model No.		APK/APCK 355			APK/APCK 450	
Ø ^(A)	Stage	2	3	4	3	4
8	kg.cm ²	-	-	-	-	-
11		-	-	-	-	-
14		-	-	-	-	-
19		-	-	-	-	-
24		-	-	-	-	-
28		-	-	-	-	-
32		-	-	-	-	-
35		-	-	15.54	-	17.76
38		-	17.72	18.19	18.52	20.17
42		25.5	22.95	23.2	23.74	25.4
48		55.14	52.74	52.42	53.49	55.18
55	89.59	-	-	-	-	

(A) Ø = Input shaft diameter.

www.e-motionsupply.com

Dimension - APK (2 Stage) Gearbox (Ratio $i = 16 \sim 55$)

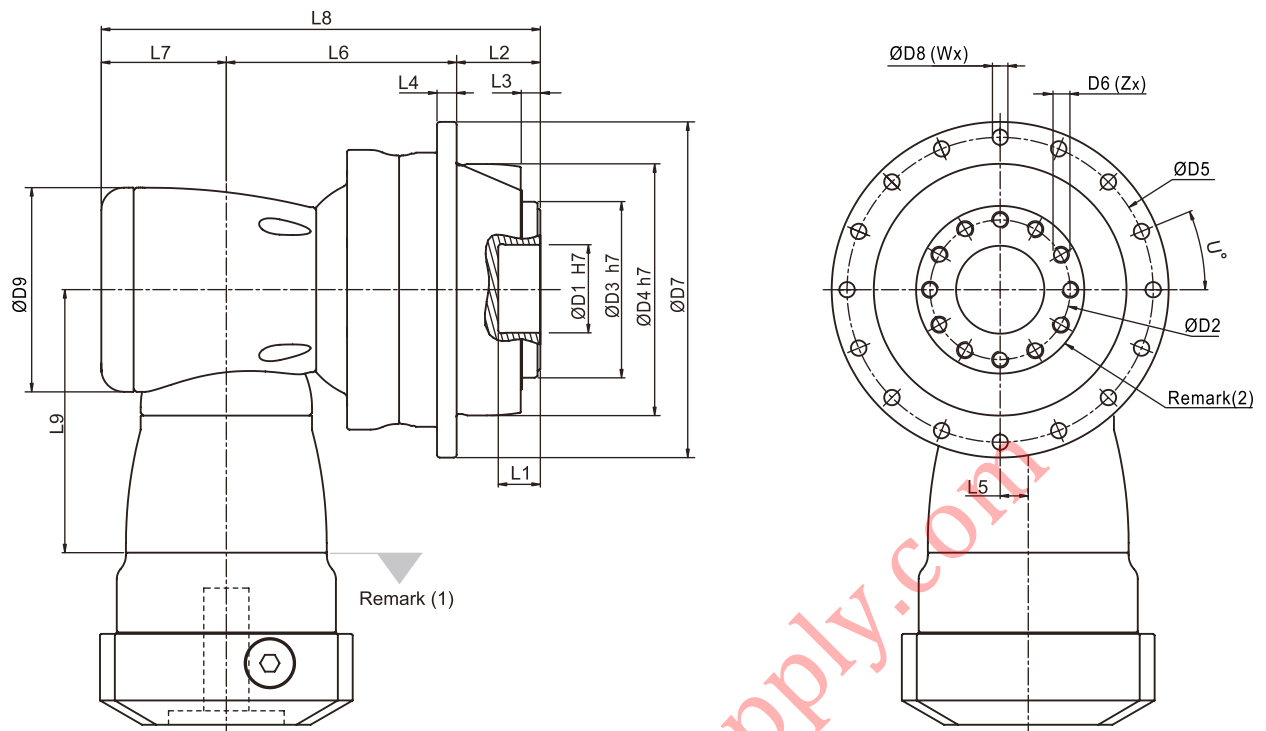

Dimension	APK 090	APK 110	APK 140	APK 200	APK 255	APK 285	APK 355
D1 H7	31.5	40	50	80	100	100	120
D2	50	63	80	125	140	160	200
D3 h7	63	80	100	160	180	200	250
D4 h7	90	110	140	200	255	285	355
D5	109	135	168	233	280	310	385
D6 x Pitch x Deep	M6x1Px11	M8x1.25Px12	M8x1.25Px15	M10x1.5Px20	M16x2Px25	M24x3Px37	M24x3Px32
D7	120	147	180	249.5	302	332	415
D8	5.5	5.5	6.6	9	13.5	13.5	17.5
D9	94	116	163	210	210	255	300
L1	15	15	15	16	16	16	35
L2	30	29	38	50	66	75	80
L3	7	7	7.5	8.5	13.5	16.5	20
L4	7	8	10	12	18	20	45
L5	13	17	25	31	31	36	43
L6	90.5	114	147.5	175	191.5	249.5	290
L7	53	68.3	89	115	115	131	165
L8	173.5	211.3	274.5	340	372.5	455.5	535
L9	114.5	129	173.5	228	228	265.5	294.5
X in Degree	30	30	22.5	22.5	24	26	22.5
Y in Degree	30	30	22.5	22.5	24	26	22.5
Z	12	12	16	16	12	12	16
U in Degree	22.5	22.5	15	15	11.25	11.25	15
W	16	16	24	24	32	32	24

(1) Dimensions are related to motor interface. Please contact APEX for details.

(2) Flange Interface, please refer to page (5).

Dimension - APK (3 Stage) Gearbox (Ratio i = 64 ~ 385)

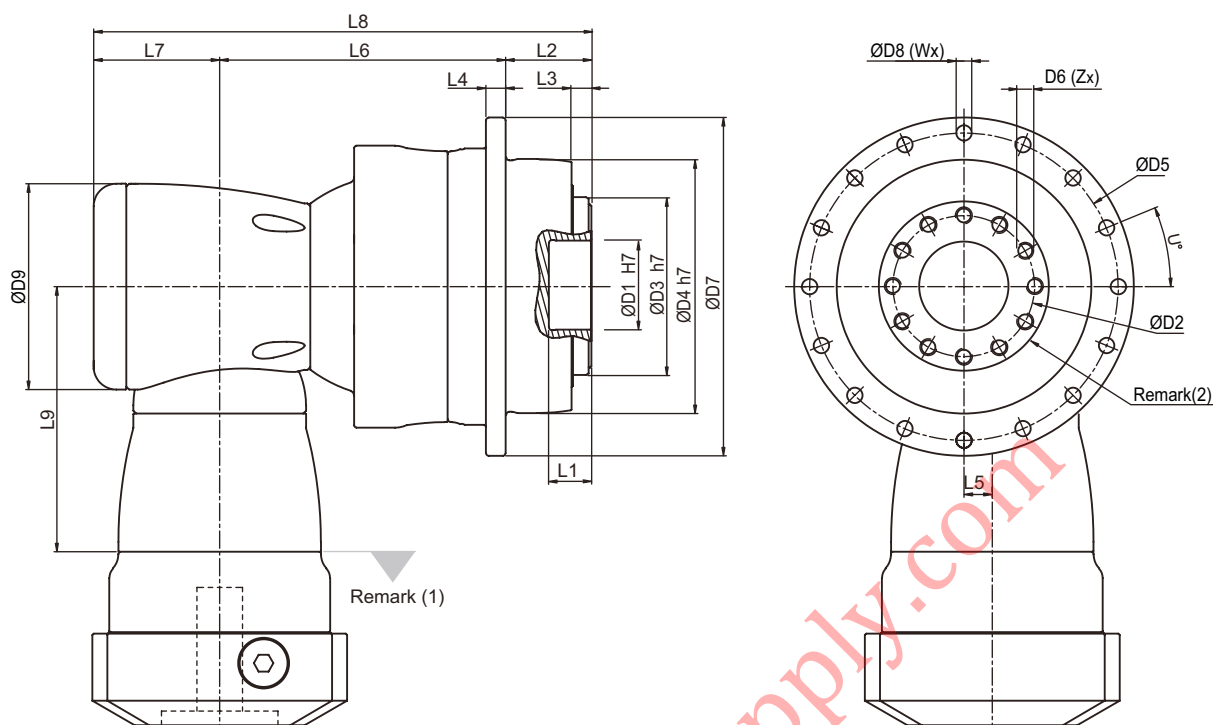

Dimension	APK 110	APK 140	APK 200	APK 255	APK 285	APK 355	APK 450
D1 H7	40	50	80	100	100	120	155
D2	63	80	125	140	160	200	250
D3 h7	80	100	160	180	200	250	315
D4 h7	110	140	200	255	285	355	450
D5	135	168	233	280	310	385	490
D6 x Pitch x Deep	M8x1.25Px12	M8x1.25Px15	M10x1.5Px20	M16x2Px25	M24x3Px37	M24x3Px32	M30x3.5Px40
D7	147	180	249.5	302	332	415	530
D8	5.5	6.6	9	13.5	13.5	17.5	22
D9	94	116	163	210	210	210	255
L1	15	15	16	16	16	35	24
L2	29	38	50	66	75	80	85
L3	7	7.5	8.5	13.5	16.5	20	20
L4	8	10	12	18	20	45	60
L5	13	17	25	31	31	31	36
L6	132	164	216.5	254.5	300	332	447.5
L7	53	68.3	89	115	115	115	131
L8	214	270.3	355.5	435.5	490	527	663.5
L9	114.5	129	173.5	228	228	228	265.5
X in Degree	30	22.5	22.5	24	26	22.5	30
Y in Degree	30	22.5	22.5	24	26	22.5	30
Z	12	16	16	12	12	16	12
U in Degree	22.5	15	15	11.25	11.25	15	15
W	16	24	24	32	32	24	24

(1) Dimensions are related to motor interface. Please contact APEX for details.

(2) Flange Interface, please refer to page (5).

Dimension - APK (4 Stage) Gearbox (Ratio i = 400 ~ 5,500)

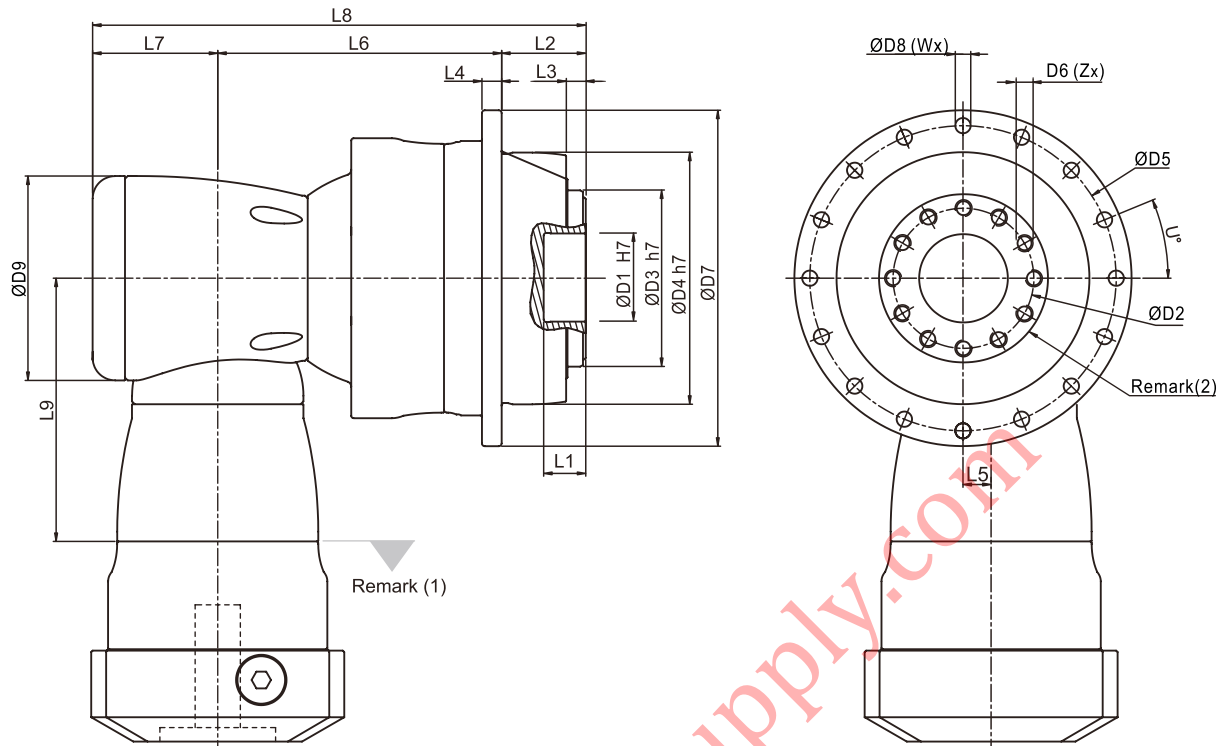

Dimension	APK 110	APK 140	APK 200	APK 255	APK 285	APK 355	APK 450
D1 H7	40	50	80	100	100	120	155
D2	63	80	125	140	160	200	250
D3 h7	80	100	160	180	200	250	315
D4 h7	110	140	200	255	285	355	450
D5	135	168	233	280	310	385	490
D6 x Pitch x Deep	M8x1.25Px12	M8x1.25Px15	M10x1.5Px20	M16x2Px25	M24x3Px37	M24x3Px32	M30x3.5Px40
D7	147	180	249.5	302	332	415	530
D8	5.5	6.6	9	13.5	13.5	17.5	22
D9	94	116	163	210	210	210	255
L1	15	15	16	16	16	35	24
L2	29	38	50	66	75	80	85
L3	7	7.5	8.5	13.5	16.5	20	20
L4	8	10	12	18	20	45	60
L5	13	17	25	31	31	31	36
L6	132	164	216.5	254.5	300	332	447.5
L7	53	68.3	89	115	115	115	131
L8	214	270.3	355.5	435.5	490	527	663.5
L9	114.5	129	173.5	228	228	228	265.5
X in Degree	30	22.5	22.5	24	26	22.5	30
Y in Degree	30	22.5	22.5	24	26	22.5	30
Z	12	16	16	12	12	16	12
U in Degree	22.5	15	15	11.25	11.25	15	15
W	16	24	24	32	32	24	24

(1) Dimensions are related to motor interface. Please contact APEX for details.

(2) Flange Interface, please refer to page (5).

Dimension - APCK (2 Stage) Gearbox (Ratio $i = 16 \sim 55$)

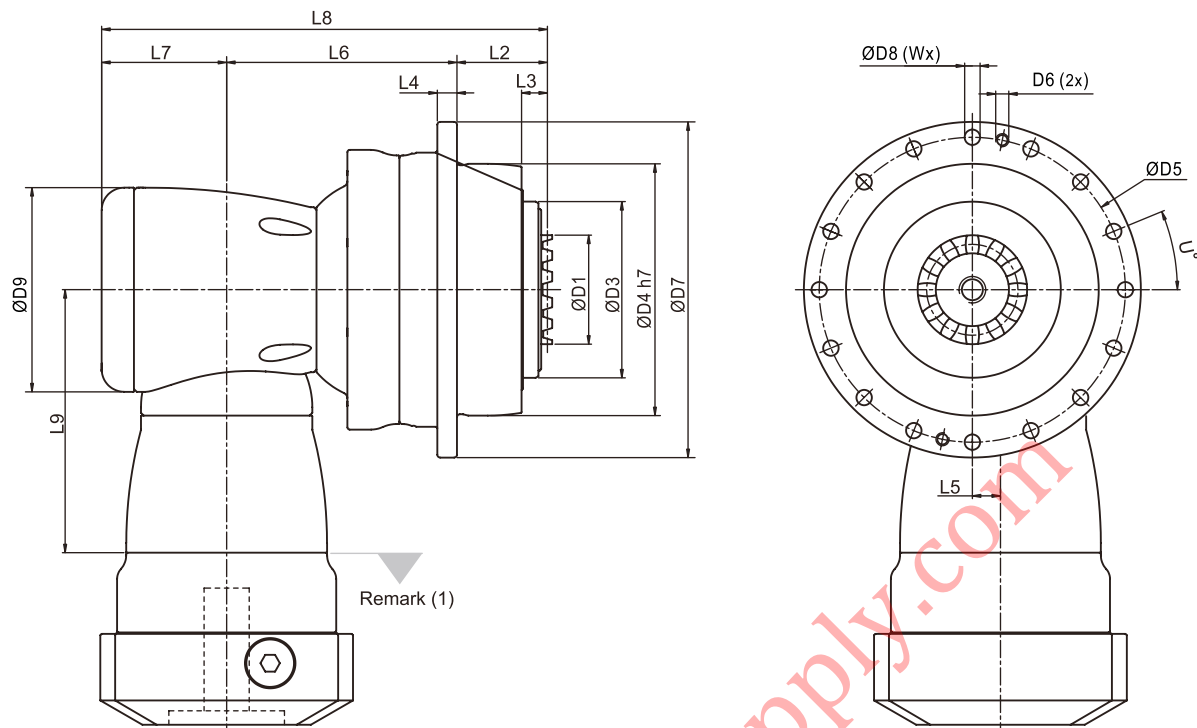

Dimension	APCK 090	APCK 110	APCK 140	APCK 200	APCK 255	APCK 285	APCK 355
D1	36	46	60	80	90	120	120
D3	63	80	100	160	180	200	250
D4 h7	90	110	140	200	255	285	355
D5	109	135	168	233	280	310	385
D6	-	-	-	-	M12	M12	M16
D7	120	147	180	249.5	302	332	415
D8	5.5	5.5	6.6	9	13.5	13.5	17.5
D9	94	116	163	210	210	255	300
L2	32.5	31.5	40.5	52.5	68.5	77.5	82.5
L3	9.5	9.5	10	11	16	19	22.5
L4	7	8	10	12	18	20	45
L5	13	17	25	31	31	36	43
L6	90.5	114	147.5	175	191.5	249.5	290
L7	53	68.3	89	115	115	131	165
L8	176	213.8	277	342.5	375	458	537.5
L9	114.5	129	173.5	228	228	265.5	294.5
U in Degree	22.5	22.5	15	15	11.25	11.25	15
W	16	16	24	24	32	32	24

(1) Dimensions are related to motor interface. Please contact APEX for details.

Dimension - APCK (3 Stage) Gearbox (Ratio i = 64 ~ 385)

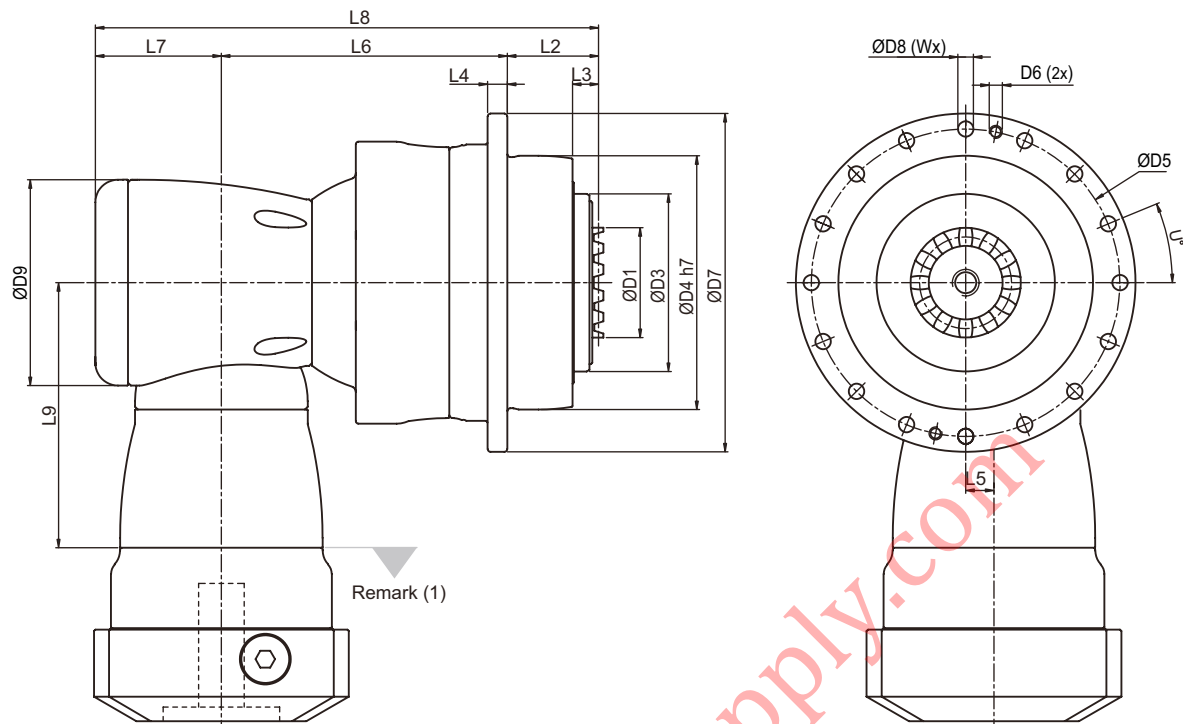

Dimension	APCK 110	APCK140	APCK 200	APCK 255	APCK 285	APCK 355	APCK 450
D1	46	60	80	90	120	120	132
D3	80	100	160	180	200	250	315
D4 h7	110	140	200	255	285	355	450
D5	135	168	233	280	310	385	490
D6	-	-	-	M12	M12	M16	M16
D7	147	180	249.5	302	332	415	530
D8	5.5	6.6	9	13.5	13.5	17.5	22
D9	94	116	163	210	210	210	255
L2	31.5	40.5	52.5	68.5	77.5	82.5	87.5
L3	9.5	10	11	16	19	22.5	22.5
L4	8	10	12	18	20	45	60
L5	13	17	25	31	31	31	36
L6	132	164	216.5	254.5	300	332	447.5
L7	53	68.3	89	115	115	115	131
L8	216.5	272.8	358	438	492.5	529.5	666
L9	114.5	129	173.5	228	228	228	265.5
U in Degree	22.5	15	15	11.25	11.25	15	15
W	16	24	24	32	32	24	24

(1) Dimensions are related to motor interface. Please contact APEX for details.

Dimension - APCK (4 Stage) Gearbox (Ratio $i = 400 \sim 5,500$)

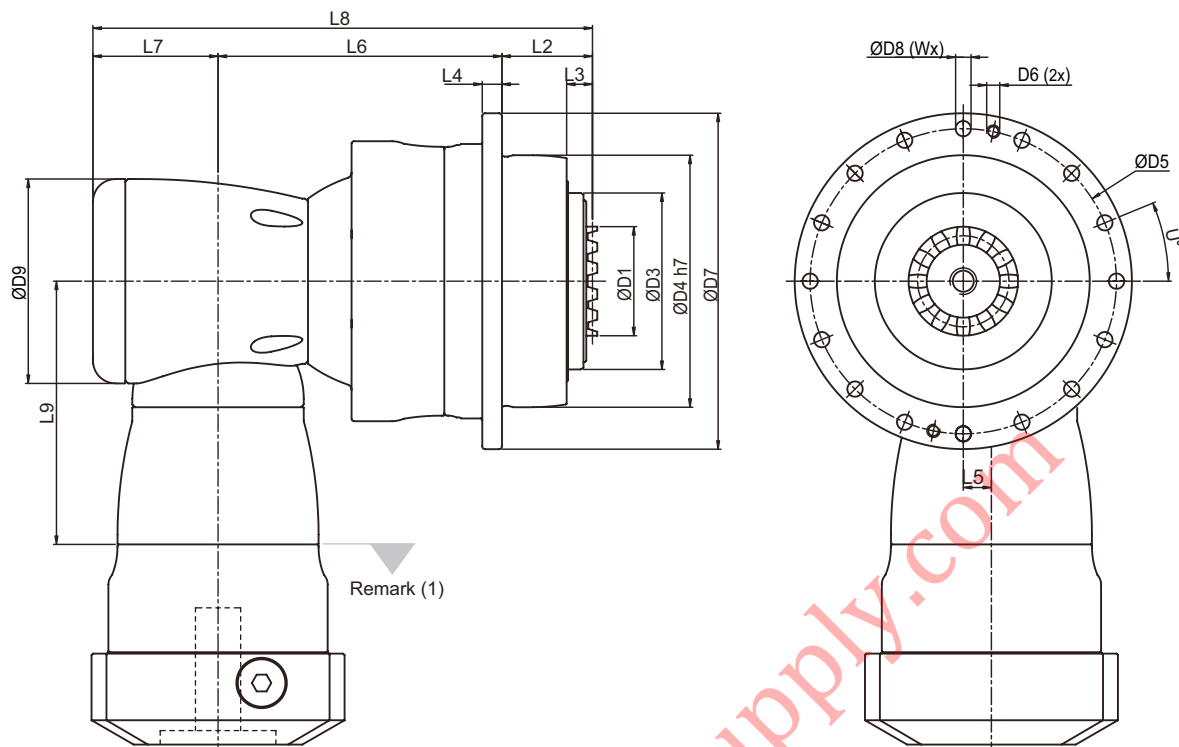

Dimension	APCK 110	APCK140	APCK 200	APCK 255	APCK 285	APCK 355	APCK 450
D1	46	60	80	90	120	120	132
D3	80	100	160	180	200	250	315
D4 h7	110	140	200	255	285	355	450
D5	135	168	233	280	310	385	490
D6	-	-	-	M12	M12	M16	M16
D7	147	180	249.5	302	332	415	530
D8	5.5	6.6	9	13.5	13.5	17.5	22
D9	94	116	163	210	210	210	255
L2	31.5	40.5	52.5	68.5	77.5	82.5	87.5
L3	9.5	10	11	16	19	22.5	22.5
L4	8	10	12	18	20	45	60
L5	13	17	25	31	31	31	36
L6	132	164	216.5	254.5	300	332	447.5
L7	53	68.3	89	115	115	115	131
L8	216.5	272.8	358	438	492.5	529.5	666
L9	114.5	129	173.5	228	228	228	265.5
U in Degree	22.5	15	15	11.25	11.25	15	15
W	16	24	24	32	32	24	24

(1) Dimensions are related to motor interface. Please contact APEX for details.

Performance - APK / APCK (2 Stage) Gearbox (Ratio = 4~11)

Model No.		Stage	Ratio ⁽¹⁾	APK 090 APCK 090	APK 110 APCK 110	APK 140 APCK 140	APK 200 APCK 200	APK 255 APCK 255	APK 285 APCK 285
Nominal Output Torque T_{2N} By n_{1N}	Nm	2	4	75	510	845	1,728	2,805	5,545
			5.5	105	440	745	1,665	2,590	4,700
			8	150	525	845	1,584	2,610	5,680
			11	210	455	765	1,710	2,655	4,800
Emergency Stop Torque T_{2NOT}	Nm	2	4~11	2 times T_{2N}					
Max. Acceleration Torque T_{2B}	Nm	2	4~11	1.5 times T_{2N}					
No Load Running Torque ⁽²⁾	Nm	2	4~11	2.5	5.8	12	25	48	95
Backlash ⁽³⁾	arcmin	2	4~11	≤ 2					
Torsional Rigidity	Nm/arcmin	2	4~11	27	56	112	389	642	1,275
Nominal Input Speed n_{1N}	rpm	2	4~11	3,600	3,000	2,300	1,800	1,500	1,100
Max. Input Speed n_{1B}	rpm	2	4~11	6,000	5,500	4,500	3,500	3,000	2,200
Max. Axial Load F_{2a} ⁽⁴⁾	N	2	4~11	2,220	4,070	8,530	17,000	26,900	39,200
Max. Tilting Moment M_{2K} ⁽⁴⁾	Nm	2	4~11	280	480	1,310	3,530	5,920	9,230
Operating Temp.	°C	2	4~11	-10° C ~ 90° C					
Degree of Gearbox Protection		2	4~11	IP65					
Lubrication		2	4~11	Synthetic lubrication grease					
Mounting Position		2	4~11	All directions					
Running Noise ⁽²⁾	dB(A)	2	4~11	≤ 68	≤ 68	≤ 70	≤ 70	≤ 72	≤ 74
Efficiency η	%	2	4~11	≥ 95%					

(1) Ratio ($i = N_{in} / N_{out}$).

(2) The dB values are measured by gearbox with ratio 11 (2-stage), no loading at 3,000 RPM or at the respective Nominal Input Speed by bigger model size.
By lower ratio and/or higher RPM, the noise level could be 3 to 5 dB higher.

(3) Backlash is measured at 2% of Nominal Output Torque T_{2N} .

(4) Applied to the output flange/curvic center at 100 rpm. The calculation formula please refer to page (3).

(5) Continuous operation is not recommended.

Max. Inertia - APK / APCK (2 Stage) Gearbox (Ratio i = 4~11)

Model No.		APK/APCK 090	APK/APCK 110	APK/APCK 140	APK/APCK 200	APK/APCK 255	APK/APCK 285
$\varnothing^{(A)}$	Stage	2st	2st	2st	2st	2st	2st
11	kg.cm ²	0.41	-	-	-	-	-
14		0.41	-	-	-	-	-
19		1.61	1.61	-	-	-	-
24		3.9	4.01	5.61	-	-	-
28		-	5.53	5.61	-	-	-
32		-	7.57	8.11	-	-	-
35		-	14.95	15.32	15.32	-	-
38		-	17.58	17.72	17.72	-	-
42		-	-	22.95	22.95	23.74	-
48		-	-	52.74	52.74	53.49	55.14
55		-	-	-	-	87.34	89.59
60		-	-	-	-	-	113.06

(A) \varnothing = Input shaft diameter.

Dimension - APK (2 Stage) Gearbox (Ratio i = 4 ~ 11)

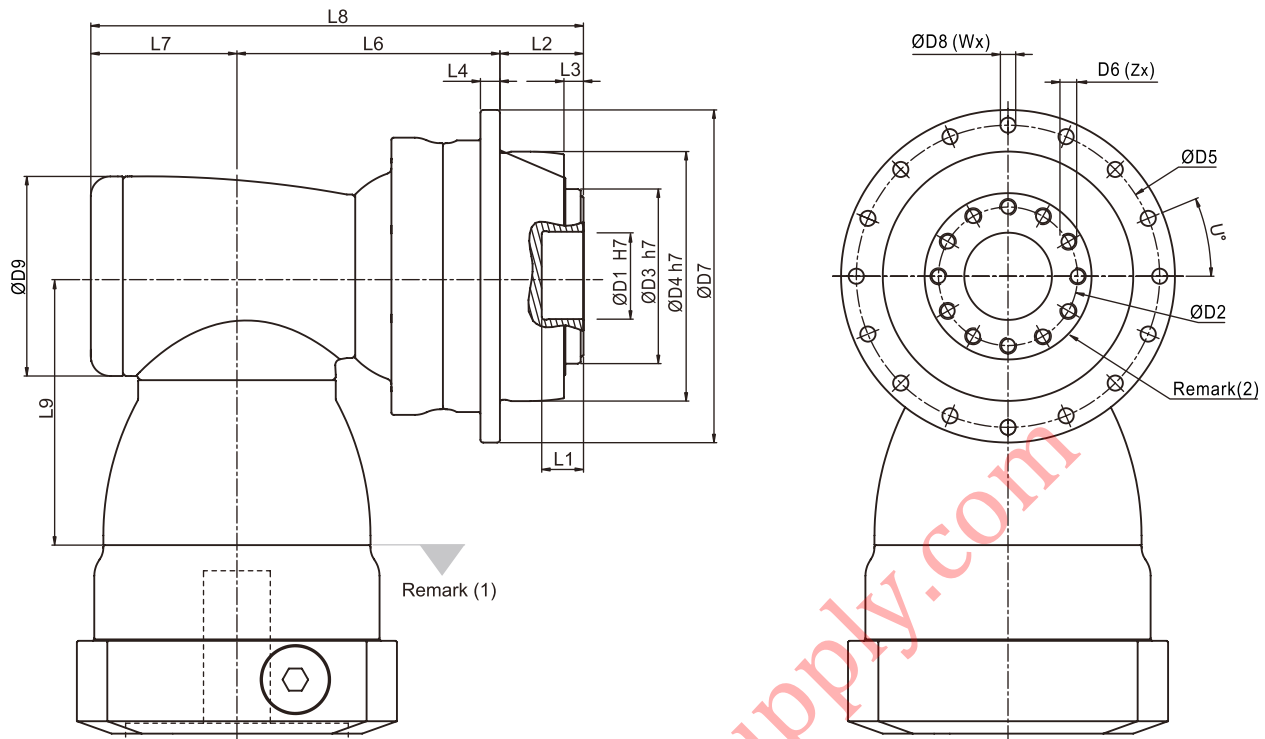

Dimension	APK 090	APK 110	APK 140	APK 200	APK 255	APK 285
D1 H7	31.5	40	50	80	100	100
D2	50	63	80	125	140	160
D3 h7	63	80	100	160	180	200
D4 h7	90	110	140	200	255	285
D5	109	135	168	233	280	310
D6 x Pitch x Deep	M6x1Px11	M8x1.25Px12	M8x1.25Px15	M10x1.5Px20	M16x2Px25	M24x3Px37
D7	120	147	180	249.5	302	332
D8	5.5	5.5	6.6	9	13.5	13.5
D9	92	116	156	156	195	240
L1	15	15	15	16	16	16
L2	30	29	38	50	66	75
L3	7	7	7.5	8.5	13.5	16.5
L4	7	8	10	12	18	20
L6	100.5	124.5	175.5	185	199	265.5
L7	61.5	76	97.5	97.5	105.5	141
L8	192	229.5	311	332.5	370.5	481.5
L9	113.5	147.5	196.5	196.5	229	260
X in Degree	30	30	22.5	22.5	24	26
Y in Degree	30	30	22.5	22.5	24	26
Z	12	12	16	16	12	12
U in Degree	22.5	22.5	15	15	11.25	11.25
W	16	16	24	24	32	32

(1) Dimensions are related to motor interface. Please contact APEX for details.

(2) Flange Interface, please refer to page (5).

Dimension - APCK (2 Stage) Gearbox (Ratio i = 4 ~ 11)

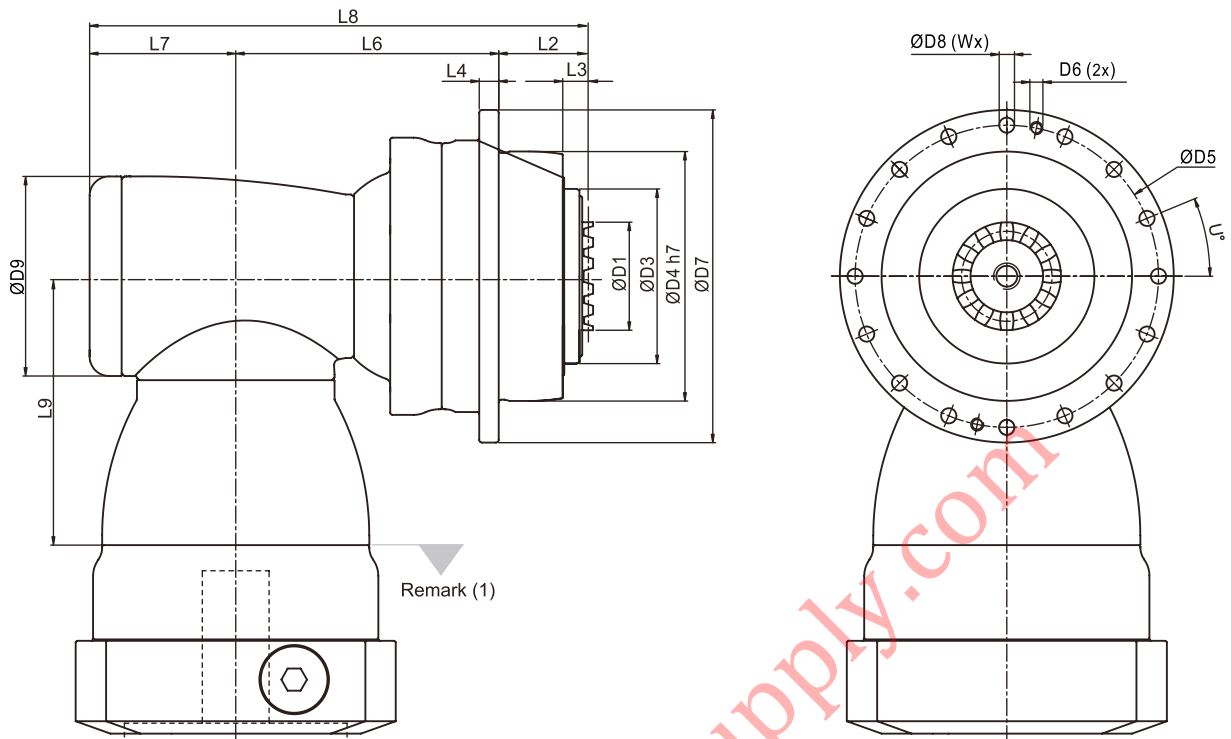

Dimension	APCK 090	APCK 110	APCK 140	APCK 200	APCK 255	APCK 285
D1	36	46	60	80	90	120
D3	63	80	100	160	180	200
D4 h7	90	110	140	200	255	285
D5	109	135	168	233	280	310
D6	-	-	-	-	M12	M12
D7	120	147	180	249.5	302	332
D8	5.5	5.5	6.6	9	13.5	13.5
D9	92	116	156	156	195	240
L2	32.5	31.5	40.5	52.5	68.5	77.5
L3	9.5	9.5	10	11	16	19
L4	7	8	10	12	18	20
L6	100.5	124.5	175.5	185	199	265.5
L7	61.5	76	97.5	97.5	105.5	141
L8	194.5	232	313.5	335	373	484
L9	113.5	147.5	196.5	196.5	229	260
U in Degree	22.5	22.5	15	15	11.25	11.25
W	16	16	24	24	32	32

(1) Dimensions are related to motor interface. Please contact APEX for details.

Rack and Pinion for AP series

Advantages of Curvic Coupling

- All-Teeth-Coupling between pinion and gearbox
- Zero backlash
- Automatic concentricity
- High torque transmission
- The Round-Out of the gearbox-pinion-set can be adjusted by switching the curvic positions.
- Quick assembly and disassembly or replacement
- More suitable pinion teeth-no. can be chosen, without interference with screwing.

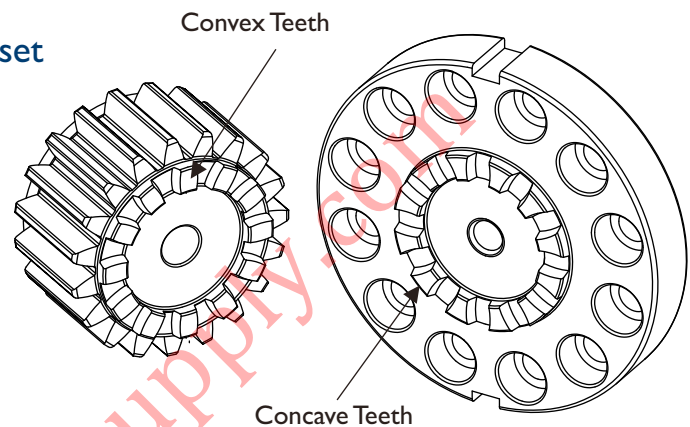

Rack with Helical Teeth

Quality 5

Module : 2~3 Alloy Steel / 4~10 Carbon Steel

Tooth Thickness Tolerance : -15 ~ 0 μm
 Right - Hand Helical
 Helical Angle β = 19° 31'42" (19.5283°)
 Pressure Angle α = 20°
 Induction Hardened
 Teeth Ground and All Sides Ground

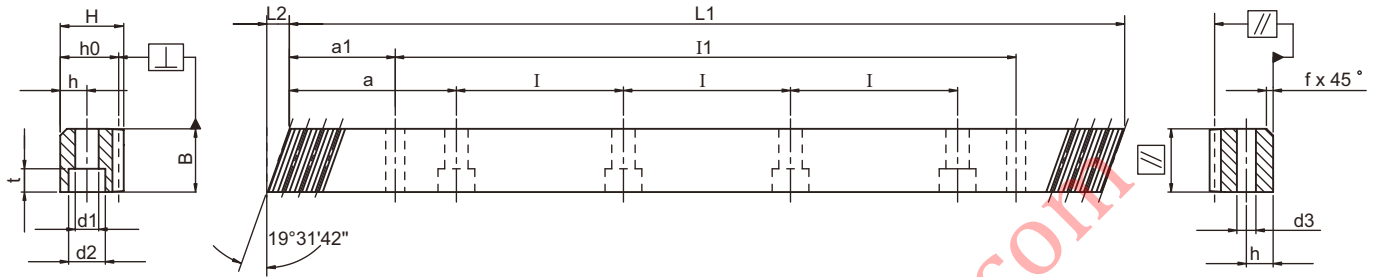

Mn	Pt ⁽¹⁾	L1	L2	Teeth No.	B	H	ho	f	a	I	Holes No.	h	d1	d2	t	a1	I1	d3	fp ⁽²⁾	Fp ⁽³⁾	Order Code
2	6.66668	500	8.5	75	24	24	22	2	62.5	125	4	8	7	11	7	31.7	436	5.7	0.0055	0.021	0205R050M10
2	6.66668	1000	8.5	150	24	24	22	2	62.5	125	8	8	7	11	7	31.7	936.6	5.7	0.006	0.024	0205R100M10
2	6.66668	1246.67	8.5	187	24	24	22	2	62.5	125	10	8	7	11	7	31.7	1183.3	5.7	0.006	0.024	0205R125M10
2	6.66668	1500	8.5	225	24	24	22	2	62.5	125	12	8	7	11	7	31.7	1436.6	5.7	0.006	0.024	0205R150M10
2	6.66668	1746.67	8.5	262	24	24	22	2	62.5	125	14	8	7	11	7	31.7	1683.3	5.7	0.006	0.024	0205R175M10
2	6.66668	2000	8.5	300	24	24	22	2	62.5	125	16	8	7	11	7	31.7	1936.6	5.7	0.007	0.027	0205R200M10
3	10.00002	500	10.3	50	29	29	26	2	62.5	125	4	9	10	15	9	35	430	7.7	0.006	0.023	0305R050M10
3	10.00002	1,000	10.3	100	29	29	26	2	62.5	125	8	9	10	15	9	35	930	7.7	0.006	0.026	0305R100M10
3	10.00002	1,250	10.3	125	29	29	26	2	62.5	125	10	9	10	15	9	35	1,180	7.7	0.006	0.026	0305R125M10
3	10.00002	1,500	10.3	150	29	29	26	2	62.5	125	12	9	10	15	9	35	1,430	7.7	0.006	0.026	0305R150M10
3	10.00002	1,750	10.3	175	29	29	26	2	62.5	125	14	9	10	15	9	35	1,680	7.7	0.006	0.026	0305R175M10
3	10.00002	2,000	10.3	200	29	29	26	2	62.5	125	16	9	10	15	9	35	1,930	7.7	0.007	0.03	0305R200M10
4	13.33335	506.67	13.8	38	39	39	35	3	62.5	125	4	12	10	15	9	33.3	433	7.7	0.007	0.025	0405R050C10
4	13.33335	1,000	13.8	75	39	39	35	3	62.5	125	8	12	10	15	9	33.3	933.4	7.7	0.007	0.028	0405R100C10
4	13.33335	1,000	13.8	75	39	39	35	3	62.5	125	8	12	14	20	13	33.3	933.4	11.7	0.007	0.028	0405R100CS0
4	13.33335	1,253.34	13.8	94	39	39	35	3	62.5	125	10	12	10	15	9	33.3	1186.7	7.7	0.007	0.028	0405R125C10
4	13.33335	1,506.67	13.8	113	39	39	35	3	62.5	125	12	12	10	15	9	33.3	1,433.4	7.7	0.007	0.028	0405R150C10
4	13.33335	1,506.67	13.8	113	39	39	35	3	62.5	125	12	12	14	20	13	33.3	1,433.4	11.7	0.007	0.028	0405R150CS0
4	13.33335	1,760	13.8	132	39	39	35	3	62.5	125	14	12	10	15	9	33.3	1,693.4	7.7	0.007	0.028	0405R175C10
4	13.33335	2,000	13.8	150	39	39	35	3	62.5	125	16	12	10	15	9	33.3	1,933.4	7.7	0.008	0.032	0405R200C10
4	13.33335	2,000	13.8	150	39	39	35	3	62.5	125	16	12	14	20	13	33.3	1,933.4	11.7	0.008	0.032	0405R200CS0
5	16.66669	1,000	17.4	60	49	39	34	3	62.5	125	8	12	14	20	13	37.5	925	11.7	0.007	0.028	0505R100C10
6	20.00003	1,000	20.9	50	59	49	43	3	62.5	125	8	16	18	26	17	37.5	925	15.7	0.007	0.028	0605R100C10
8	26.66671	960	28	36	79	79	71	3	60	120	8	25	22	33	21	120	720	19.7	0.008	0.031	0805R100C10
10	33.33339	1,000	35.1	30	99	99	89	3	62.5	125	8	32	33	48	32	125	750	19.7	0.008	0.031	1005R100C10

(1) Teeth Pitch Pt = Module x π / cos β (2) fp = Single Pitch Error (3) Fp = Total Pitch Error

● Please refer to APEX Rack & Pinion catalog for other models

Pinion with Curvic Coupling

Quality DIN4 / Alloy Steel

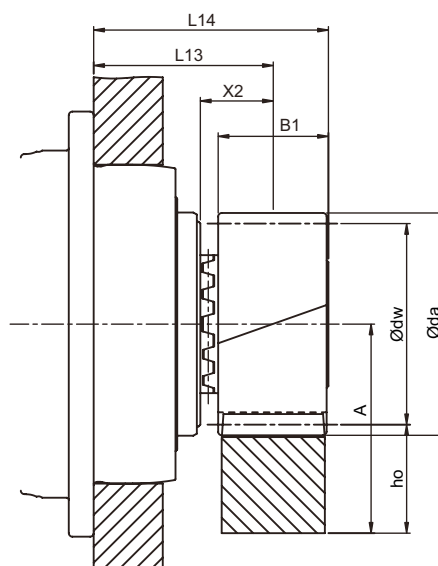

Tooth Thickness Tolerance : e24
 Left - Hand Helical
 Helical Angle $\beta = 19^\circ 31'42'' (19.5283^\circ)$
 Pressure Angle $\alpha = 20^\circ$
 Case - Hardened and Teeth Ground

$$A = h_o + \frac{\text{Ø}dw}{2}$$

Gearbox Model	Mn	Z ⁽¹⁾	X ⁽²⁾	da ⁽³⁾	d ⁽⁴⁾	dw ⁽⁵⁾	B1	X2	L13	L14	L ⁽⁶⁾	DI ⁽⁷⁾	Order Code
APC/APCK 090	3	17	0.441	62.76	54.113	56.76	31	20.5	50.5	66	170	36	A03L17
APC/APCK 110	3	20	0.3897	72	63.662	66	31	20.5	49.5	65	200	46	A03L20
APC/APCK 140	4	19	0.4102	91.92	80.639	83.92	41	25.5	63.5	84	253.335	60	A04L19
APC/APCK 200	5	19	0.4002	114.8	100.798	104.8	51	30.5	80.5	106	316.666	80	A05L19
APC/APCK 255	6	19	0.4035	137.8	120.958	125.8	61	35.5	101.5	132	380	90	A06L19
APC/APCK 285	8	19	0.4108	183.85	161.277	167.85	81	45.5	120.5	161	506.667	120	A08L19
APC/APCK 355	8	19	0.4108	183.85	161.277	167.85	81	45.5	125.5	166	506.667	120	A08L19
APC/APCK 450	10	18	0.4257	219.5	190.986	199.5	101	55.5	140.5	191	600	132	A10L18

(1) Number of teeth (2) Profile modification factor (3) Diameter of addendum circle (4) Pitch circle diameter (5) Working pitch circle diameter

(6) Pitch circle length $L = \pi \times d$ (7) Curvic specification

Pinion material carburized surface hardness reached 60 HRC.

Teeth surface ground to reduce noise and improve wear resistance.

■ Table I. The max permitted torque and feed-force of rack and pinion.

Unit	Mn	Z ⁽¹⁾	dw ⁽²⁾	F _{2T} ⁽³⁾	T _{2B} ⁽⁴⁾	M
Gearbox Model	[mm]		[mm]	[N]	[Nm]	[kg]
APC/APCK 090	3	17	56.76	18,110	390	0.7
APC/APCK 110	3	20	66	18,535	590	0.92
APC/APCK 140	4	19	83.92	31,003	1,250	1.98
APC/APCK 200	5	19	104.8	48,612	2,450	3.81
APC/APCK 255	6	19	125.8	63,907	3,865	6.61
APC/APCK 285	8	19	167.85	131,265	10,585	15.49
APC/APCK 355 ⁽⁵⁾	8	19	167.85	131,761	10,625	15.49
APC/APCK 450 ⁽⁵⁾	10	18	199.5	204,308	19,510	28.13

(1) Number of teeth (2) Working pitch circle diameter (3) Maximal Feed-Force (4) Maximal Driving Torque (5) Calculated under the basis of speed 1.5 m/s

- In Table I, the max. permissible torque of the curvic plate pinion and the rack is calculated under the basis of speed 3 m/s. This condition is under providing good lubrication (using the automatic lubrication system or applied grease manually every day), the tooth root strength factor $SF \geq 1.4$, teeth surface strength coefficient $SH \geq 1$, the safety factor $SB = 1$ and the required service life of 20,000 hours. By higher speed, the max. permissible torque reduced. The user needs to increase the safety factor for the application. Please visit APEX website (www.apexdyna.com/) for the backlash value by different center height.

Pinion with Helical Teeth (Interface : Curvic Plate / EN ISO 9409-I-A)

Quality DIN4 / Alloy Steel

Tooth Thickness Tolerance : e24
 Left - Hand Helical Teeth
 Helical Angle $\beta = 19^\circ 31'42'' (19.5283^\circ)$
 Pressure Angle $\alpha = 20^\circ$
 Case - Hardened and Teeth Ground

AP / APK 090

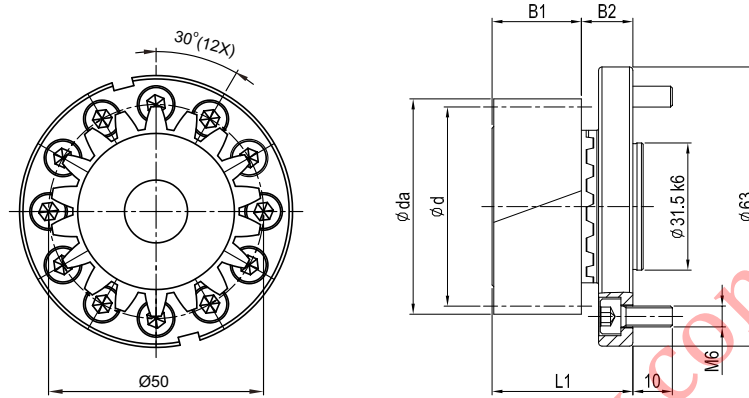

Mn	Z ⁽¹⁾	X ⁽²⁾	da ⁽³⁾	d ⁽⁴⁾	dw ⁽⁵⁾	B1	B2	L1	L ⁽⁶⁾	D1 ⁽⁷⁾	Locking screws for pinion	Order Code	
												Set	Pinion only
2	20	0.390	48	42.441	44	26	15	41	133.334	36	M10	A02L20P050	A02L20
3	17	0.441	62.76	54.113	56.76	31	15	46	170	36	M10	A03L17P050	A03L17

AP / APK 110

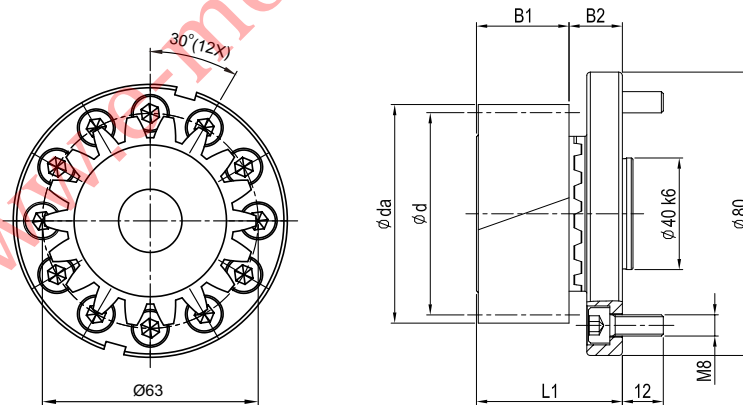

Mn	Z ⁽¹⁾	X ⁽²⁾	da ⁽³⁾	d ⁽⁴⁾	dw ⁽⁵⁾	B1	B2	L1	L ⁽⁶⁾	D1 ⁽⁷⁾	Locking screws for pinion	Order Code	
												Set	Pinion only
2	20	0.390	48	42.441	44	26	19.5	45.5	133.334	36	M10	A02L20C063	A02L20
3	20	0.390	72	63.662	66	31	19.5	50.5	200	46	M12	A03L20C063	A03L20

Pinion with Helical Teeth (Interface : Curvic Plate / EN ISO 9409-I-A)

Quality DIN4 / Alloy Steel

Tooth Thickness Tolerance : e24
 Left - Hand Helical Teeth
 Helical Angle $\beta = 19^\circ 31'42'' (19.5283^\circ)$
 Pressure Angle $\alpha = 20^\circ$
 Case - Hardened and Teeth Ground

AP / APK 140

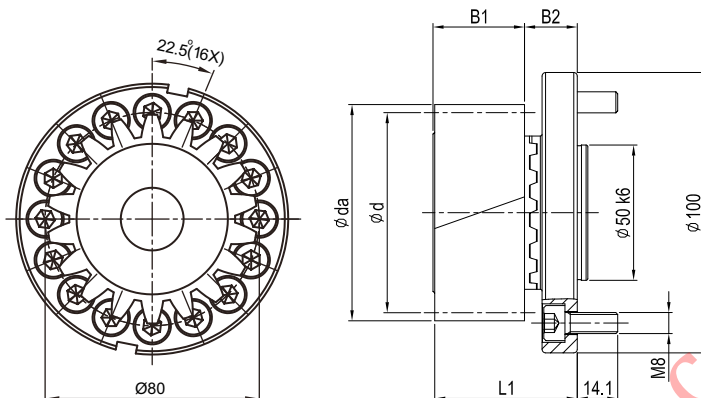

Mn	Z ⁽¹⁾	X ⁽²⁾	da ⁽³⁾	d ⁽⁴⁾	dw ⁽⁵⁾	B1	B2	L1	L ⁽⁶⁾	D1 ⁽⁷⁾	Locking screws for pinion	Order Code	
												Set	Pinion only
3	18	0.118	64	57.296	58	31	21.5	52.5	180	46	M12	A03L18P080	A03L18
	20	0.390	72	63.662	66	31	21.5	52.5	200	46	M12	A03L20P080	A03L20
4	19	0.410	91.92	80.639	83.92	41	21.5	62.5	253.335	60	M16	A04L19P080	A04L19

AP / APK 200

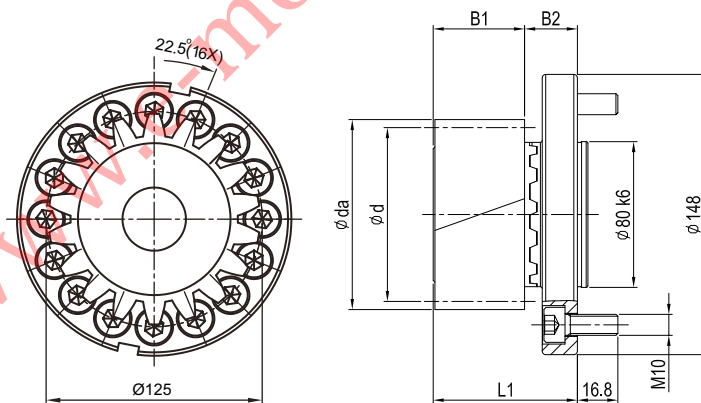

Mn	Z ⁽¹⁾	X ⁽²⁾	da ⁽³⁾	d ⁽⁴⁾	dw ⁽⁵⁾	B1	B2	L1	L ⁽⁶⁾	D1 ⁽⁷⁾	Locking screws for pinion	Order Code	
												Set	Pinion only
4	18	0.638	89.5	76.394	81.5	41	29	70	240	68	M16	A04L18P125	A04L18
	20	0.190	94.4	84.883	86.4	41	29	70	266.667	68	M16	A04L20P125	A04L20
5	19	0.400	114.8	100.798	104.8	51	29	80	316.666	80	M20	A05L19P125	A05L19

Pinion with Helical Teeth (Interface : Curvic Plate / EN ISO 9409-I-A)

Quality DIN4 / Alloy Steel

Tooth Thickness Tolerance : e24
 Left - Hand Helical Teeth
 Helical Angle $\beta = 19^\circ 31'42'' (19.5283^\circ)$
 Pressure Angle $\alpha = 20^\circ$
 Case - Hardened and Teeth Ground

AP / APK 255

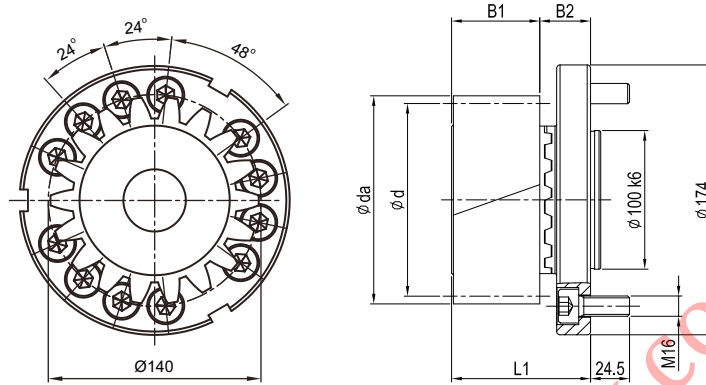

Mn	Z ⁽¹⁾	X ⁽²⁾	da ⁽³⁾	d ⁽⁴⁾	dw ⁽⁵⁾	B1	B2	L1	L ⁽⁶⁾	DI ⁽⁷⁾	Locking screws for pinion	Order Code	
												Set	Pinion only
5	18	0.251	108	95.493	98	51	38	89	300	80	M20	A05L18A140	A05L18
	19	0.400	114.8	100.798	104.8	51	38	89	316.667	80	M20	A05L19A140	A05L19
6	19	0.404	137.8	120.958	125.8	61	38	99	380	90	M24	A06L19A140	A06L19

AP / APK 285

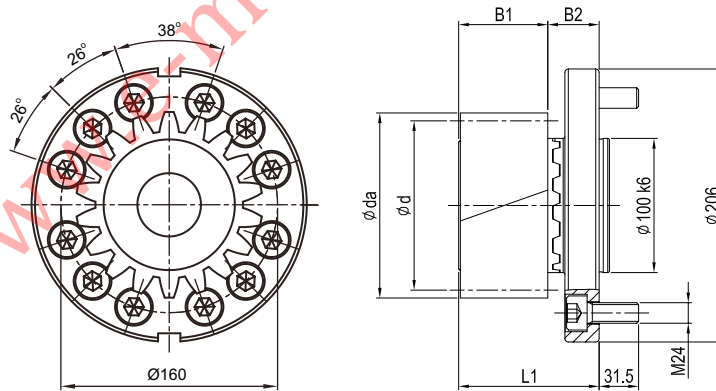

Mn	Z ⁽¹⁾	X ⁽²⁾	da ⁽³⁾	d ⁽⁴⁾	dw ⁽⁵⁾	B1	B2	L1	L ⁽⁶⁾	DI ⁽⁷⁾	Locking screws for pinion	Order Code	
												Set	Pinion only
6	18	0.201	129	114.592	117	61	49	110	360	90	M24	A06L18P160	A06L18
	19	0.404	137.8	120.958	125.8	61	49	110	380	90	M24	A06L19P160	A06L19
8	19	0.411	183.85	161.277	167.85	81	49	130	506.667	120	M30	A08L19P160	A08L19

Pinion with Helical Teeth (Interface : Curvic Plate / EN ISO 9409-I-A)

AP / APK 355

Quality DIN4 / Alloy Steel

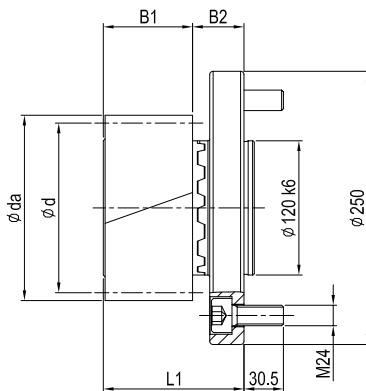
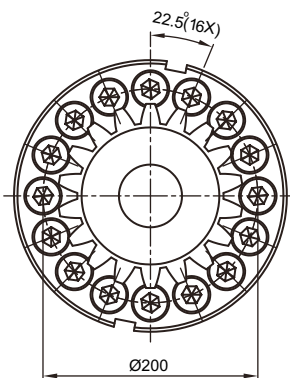

Tooth Thickness Tolerance : e24
 Left - Hand Helical Teeth
 Helical Angle $\beta = 19^\circ 31'42'' (19.5283^\circ)$
 Pressure Angle $\alpha = 20^\circ$
 Case - Hardened and Teeth Ground

Mn	Z ⁽¹⁾	X ⁽²⁾	da ⁽³⁾	d ⁽⁴⁾	dw ⁽⁵⁾	B1	B2	L1	L ⁽⁶⁾	D1 ⁽⁷⁾	Locking screws for pinion	Order Code	
												Set	Pinion only
8	15	0.355	149	127.324	133	81	50	131	400	108	M30	A08L15A200	A08L15
	19	0.411	183.85	161.277	167.85	81	50	131	506.667	120		A08L19A200	A08L19

AP / APK 450

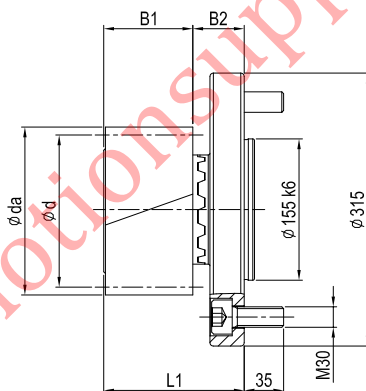
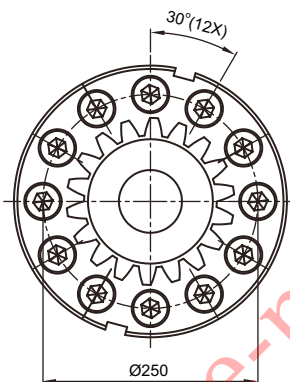

Mn	Z ⁽¹⁾	X ⁽²⁾	da ⁽³⁾	d ⁽⁴⁾	dw ⁽⁵⁾	B1	B2	L1	L ⁽⁶⁾	D1 ⁽⁷⁾	Locking screws for pinion	Order Code	
												Set	Pinion only
10	14	0.523	179	148.545	159	101	62	163	466.667	132	M36	A10L14A250	A10L14
	18	0.426	219.5	190.986	199.5	101	62	163	600	132		A10L18A250	A10L18

(1) Number of teeth (2) Profile modification factor (3) Diameter of addendum circle (4) Pitch circle diameter (5) Working pitch circle diameter (6) Pitch circle length $L = \pi \cdot d$ (7) Curvic specification

- Pinion material carburized, surface hardness reached 60 HRC.
- Teeth surface ground to reduce noise and improve wear resistance.
- Accessories include hexagon socket head cap screws (Strength 12.9 , DIN 912)
- The strength of screws is limits the max. transmission torque. Please refer to the table below :

PCD of Flange	Bolt / Screw Size	Max. Torque (Nm)
Ø50	M6 x 12 PCS	265
Ø63	M8 x 12 PCS	640
Ø80	M8 x 16 PCS	1,160
Ø125	M10 x 16 PCS	2,960
Ø140	M16 x 12 PCS	6,620
Ø160	M24 x 12 PCS	18,160
Ø200	M24 x 16 PCS	29,170
Ø250	M30 x 12 PCS	44,320

- Tightening torque recommended for bolt.

Screws	Screws tightening torque(Nm)
M5 x 0.8P	9.8
M6 x 1P	17
M8 x 1.25P	41
M10 x 1.5P	80
M12 x 1.75P	139
M16 x 2P	343
M20 x 2.5P	692
M24 x 3P	1,190
M30 x 3.5P	2,380
M36 x 4P	4,136

- The maximum permissible torque of the rack

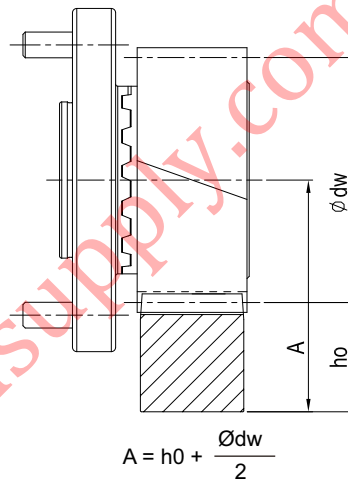

- In Table 2, the maximum permissible torque of the pinion Curvic Plate and the rack is calculated on the basis of a speed of 1.5 m/s and providing good lubrication (using an automatic lubrication system or manually applied grease every day), the tooth root strength factor $SF \geq 1.4$, tooth surface strength coefficient $SH \geq 1$, the safety factor $SB \geq 1$, and the required service life of 20,000 hours. By higher speed, the max. permissible torque reduced. The user needs to increase the safety factor for the application.
- Backlash changes by different center height. Please contact APEX under (WWW.APEXDYNA.COM).

■ Table 2. The max. permitted torque and feed-force of pinion Curvic Plate.

Mn [mm]	Z ⁽¹⁾ 【】	dw ⁽²⁾ [mm]	Fz ⁽³⁾ 【N】	TzB ⁽⁴⁾ 【Nm】
2	17	37.84	8,870	160
	20	44	9,896	210
3	17	56.76	18,110	390
	18	58	20,420	585
4	20	66	18,535	590
	18	81.5	30,761	1,175
5	19	83.92	32,247	1,300
	20	86.4	29,452	1,250
6	18	98	56,339	2,690
	19	104.8	56,649	2,855
8	18	117	77,580	4,445
	19	125.8	73,662	4,455
10	15	133	135,717	8,640
	19	167.85	131,761	10,625
10	14	159	189,707	14,090
	18	199.5	204,308	19,510

(1) Number of teeth (2) Working Pitch Circle Diameter (in mm) (3) Maximum Feed-Force (4) Maximum Driving Torque

Rack with Straight Teeth

Quality 5

Module : 2~3 Alloy Steel / 4~10 Carbon Steel

Tooth Thickness Tolerance : -15 ~ 0 μm

Straight teeth

Pressure Angle $\alpha = 20^\circ$

Induction Hardened

Teeth Ground and All Sides Ground

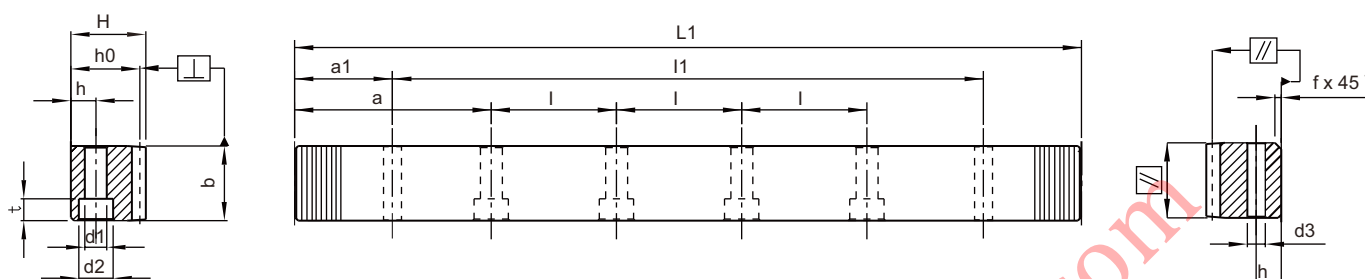

Mn	P ⁽¹⁾	L1	No. Teeth	B	H	h ₀	f	a	l	No. Holes	h	d1	d2	t	a1	l1	d3	fp ⁽²⁾	Fp ⁽³⁾	Order Code
2	6.28319	251.33	40	24	24	22	2	62.83	125.66	2	8	7	11	7	31.3	188.73	5.7	0.005	0.018	02051025M10
2	6.28319	502.66	80	24	24	22	2	62.83	125.66	4	8	7	11	7	31.3	440.06	5.7	0.0055	0.021	02051050M10
2	6.28319	1005.31	160	24	24	22	2	62.83	125.66	8	8	7	11	7	31.3	942.71	5.7	0.006	0.024	02051100M10
3	9.42478	254.47	27	29	29	26	2	63.62	127.23	2	9	10	15	9	34.4	185.67	7.7	0.0055	0.019	03051025M10
3	9.42478	508.94	54	29	29	26	2	63.62	127.23	4	9	10	15	9	34.4	440.14	7.7	0.006	0.023	03051050M10
3	9.42478	1017.88	108	29	29	26	2	63.62	127.23	8	9	10	15	9	34.4	949.05	7.7	0.006	0.026	03051100M10
4	12.56637	251.33	20	39	39	35	3	62.83	125.66	2	12	10	15	9	37.5	176.33	7.7	0.006	0.021	04051025C10
4	12.56637	502.66	40	39	39	35	3	62.83	125.66	4	12	10	15	9	37.5	427.66	7.7	0.007	0.026	04051050C10
4	12.56637	1005.31	80	39	39	35	3	62.83	125.66	8	12	10	15	9	37.5	930.31	7.7	0.007	0.028	04051100C10
4	12.56637	1005.31	80	39	39	35	3	62.83	125.66	8	12	14	20	13	37.5	930.31	11.7	0.007	0.028	04051100CS0
4	12.56637	1256.64	100	39	39	35	3	62.83	125.66	10	12	10	15	9	37.5	181.64	7.7	0.007	0.028	04051125C10
4	12.56637	1507.96	120	39	39	35	3	62.83	125.66	12	12	10	15	9	37.5	432.96	7.7	0.007	0.028	04051150C10
4	12.56637	1507.96	120	39	39	35	3	62.83	125.66	12	12	14	20	13	37.5	432.96	11.7	0.007	0.028	04051150CS0
4	12.56637	1759.29	140	39	39	35	3	62.83	125.66	14	12	10	15	9	37.5	684.29	7.7	0.007	0.028	04051175C10
4	12.56637	2010.62	160	39	39	35	3	62.83	125.66	16	12	10	15	9	37.5	935.62	7.7	0.008	0.032	04051200C10
4	12.56637	2010.62	160	39	39	35	3	62.83	125.66	16	12	14	20	13	37.5	935.62	11.7	0.008	0.032	04051200CS0
5	15.70796	1005.31	64	49	39	34	3	62.83	125.66	8	12	14	20	13	30.1	945.11	11.7	0.007	0.028	05051100C10
6	18.84956	1017.88	54	59	49	43	3	63.62	127.23	8	16	18	26	17	31.4	955.08	15.7	0.007	0.028	06051100C10
8	25.13274	1005.31	40	79	79	71	3	62.83	125.66	8	25	22	33	21	26.6	952.11	19.7	0.008	0.031	08051100C10
10	31.41593	1005.31	32	99	99	89	3	62.83	125.66	8	32	33	48	32	125.66	753.99	19.7	0.008	0.031	10051100C10

(1) Teeth Pitch $P_t = \text{Module} \times \pi / \cos \beta$ (2) $f_p = \text{Single Pitch Error}$ (3) $F_p = \text{Total Pitch Error}$

- Material Carburized.
- Induction hardened after carburized and ground.
- All sides ground.

Pinion with Straight Teeth (Interface : Curvic Plate / EN ISO 9409-I-A)

Quality DIN4 / Alloy Steel

Tooth Thickness Tolerance : e24
 Straight Teeth
 Pressure Angle $\alpha = 20^\circ$
 Case - Hardened and Teeth Ground

AP / APK 090

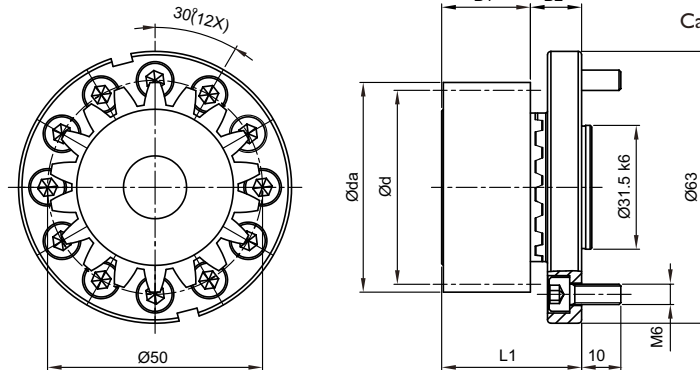

Mn	Z ⁽¹⁾	X ⁽²⁾	da ⁽³⁾	d ⁽⁴⁾	dw ⁽⁵⁾	B1	B2	L1	L ⁽⁶⁾	DI ⁽⁷⁾	Locking screws for pinion	Order Code	
												Set	Pinion only
2	21	0.5	48	42	44	26	15	41	131.947	36	M10	A02121P050	A02121

AP / APK 110

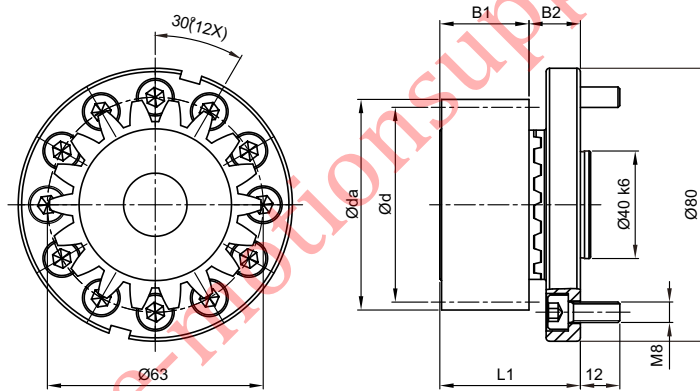

Mn	Z ⁽¹⁾	X ⁽²⁾	da ⁽³⁾	d ⁽⁴⁾	dw ⁽⁵⁾	B1	B2	L1	L ⁽⁶⁾	DI ⁽⁷⁾	Locking screws for pinion	Order Code	
												Set	Pinion only
2	21	0.5	48	42	44	26	19.5	45.5	131.947	36	M10	A02121C063	A02121

AP / APK 140

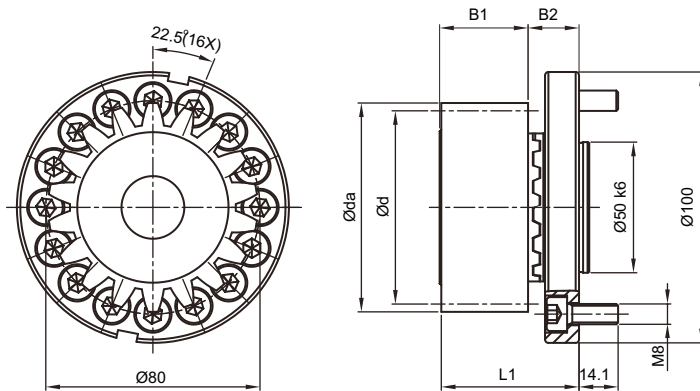

Mn	Z ⁽¹⁾	X ⁽²⁾	da ⁽³⁾	d ⁽⁴⁾	dw ⁽⁵⁾	B1	B2	L1	L ⁽⁶⁾	DI ⁽⁷⁾	Locking screws for pinion	Order Code	
												Set	Pinion only
3	19	0.1667	64	57	58	31	21.5	52.5	179.071	46	M12	A03119P080	A03119

Pinion with Straight Teeth (Interface : Curvic Plate / EN ISO 9409-I-A)

Quality DIN4 / Alloy Steel

Tooth Thickness Tolerance : e24

Straight Teeth

Pressure Angle $\alpha = 20^\circ$

Case - Hardened and Teeth Ground

AP / APK 200

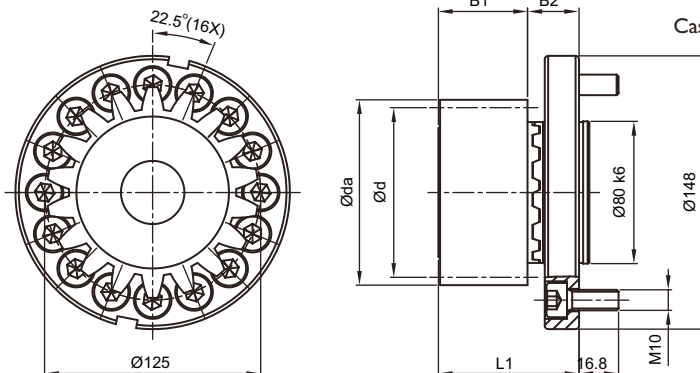

Mn	Z ⁽¹⁾	X ⁽²⁾	da ⁽³⁾	d ⁽⁴⁾	dw ⁽⁵⁾	B1	B2	L1	L ⁽⁶⁾	D1 ⁽⁷⁾	Locking screws for pinion	Order Code	
												Set	Pinion only
4	19	0.6875	89.5	76	81.5	41	29	70	238.761	68	M16	A04119P125	A04119

AP / APK 255

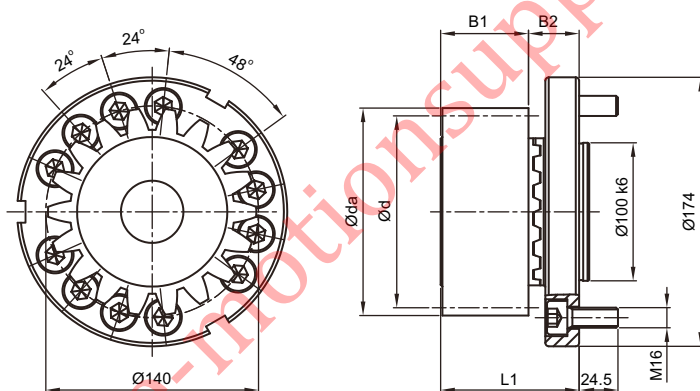

Mn	Z ⁽¹⁾	X ⁽²⁾	da ⁽³⁾	d ⁽⁴⁾	dw ⁽⁵⁾	B1	B2	L1	L ⁽⁶⁾	D1 ⁽⁷⁾	Locking screws for pinion	Order Code	
												Set	Pinion only
5	19	0.3	108	95	98	51	38	89	298.451	80	M20	A05119A140	A05119

AP / APK 285

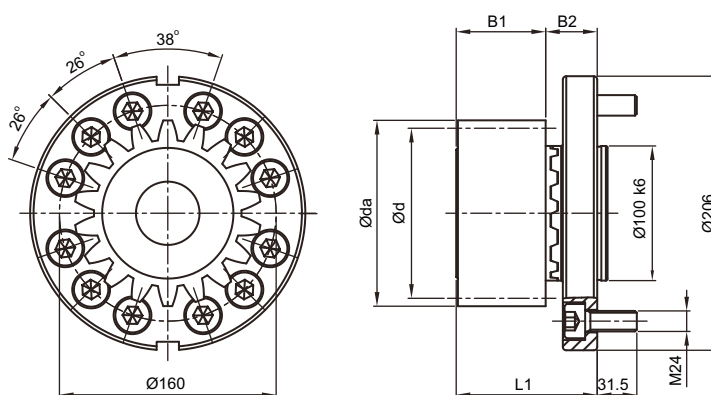

Mn	Z ⁽¹⁾	X ⁽²⁾	da ⁽³⁾	d ⁽⁴⁾	dw ⁽⁵⁾	B1	B2	L1	L ⁽⁶⁾	D1 ⁽⁷⁾	Locking screws for pinion	Order Code	
												Set	Pinion only
6	19	0.25	129	114	117	61	49	110	358.142	90	M24	A06119P160	A06119

Pinion with Straight Teeth (Interface : Curvic Plate / EN ISO 9409-I-A)

Quality DIN4 / Alloy Steel

AP / APK 355

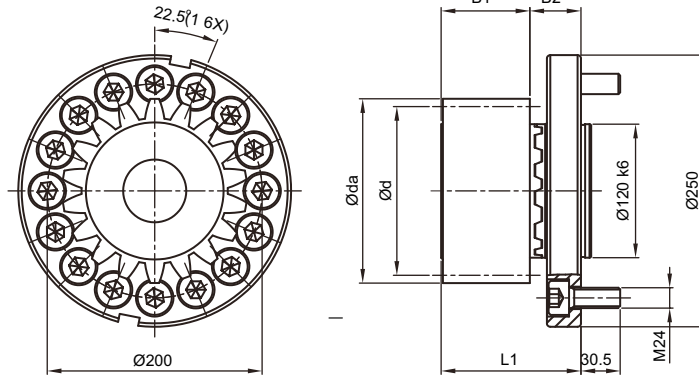

Tooth Thickness Tolerance : e24
 Straight Teeth
 Pressure Angle $\alpha = 20^\circ$
 Case - Hardened and Teeth Ground

Mn	Z ⁽¹⁾	X ⁽²⁾	da ⁽³⁾	d ⁽⁴⁾	dw ⁽⁵⁾	B1	B2	L1	L ⁽⁶⁾	DI ⁽⁷⁾	Locking screws for pinion	Order Code	
												Set	Pinion only
8	16	0.3125	0.3125	128	133	81	50	131	402.124	108	M30	A08116A200	A08116

AP / APK 450

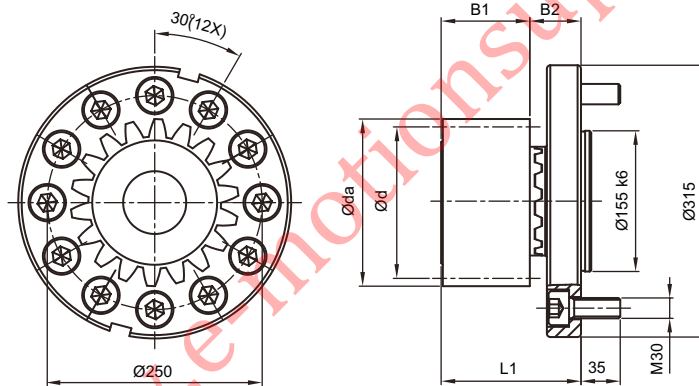

Mn	Z ⁽¹⁾	X ⁽²⁾	da ⁽³⁾	d ⁽⁴⁾	dw ⁽⁵⁾	B1	B2	L1	L ⁽⁶⁾	DI ⁽⁷⁾	Locking screws for pinion	Order Code	
												Set	Pinion only
10	15	0.45	179	150	159	101	62	163	471.239	132	M36	A10115A250	A10115

(1) Number of teeth (2) Profile modification factor (3) Diameter of addendum circle (4) Pitch circle diameter (5) Working pitch circle diameter (6) Pitch circle length $L = \pi * d$ (7) Curvic specification

- Pinion material carburized, surface hardness reached 60 HRC.
- Teeth surface ground to reduce noise and improve wear resistance.
- Accessories include hexagon socket head cap screws (Strength 12.9 , DIN 912)
- The strength of screws is limits the max. transmission torque. Please refer to the table below :

PCD of Flange	Bolt / Screw Size	Max. Torque (Nm)
Ø50	M6 x 12 PCS	265
Ø63	M8 x 12 PCS	640
Ø80	M8 x 16 PCS	1,160
Ø125	M10 x 16 PCS	2,960
Ø140	M16 x 12 PCS	6,620
Ø160	M24 x 12 PCS	18,160
Ø200	M24 x 16 PCS	29,170
Ø250	M30 x 12 PCS	44,320

- Tightening torque recommended for bolt.

Screws	Screws tightening torque(Nm)
M5 x 0.8P	9.8
M6 x 1P	17
M8 x 1.25P	41
M10 x 1.5P	80
M12 x 1.75P	139
M16 x 2P	343
M20 x 2.5P	692
M24 x 3P	1,190
M30 x 3.5P	2,380
M36 x 4P	4,136

- The maximum permissible torque of the rack

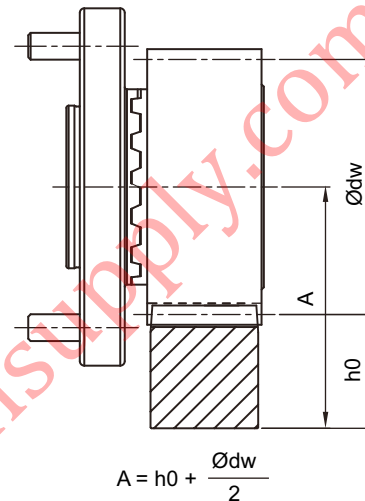
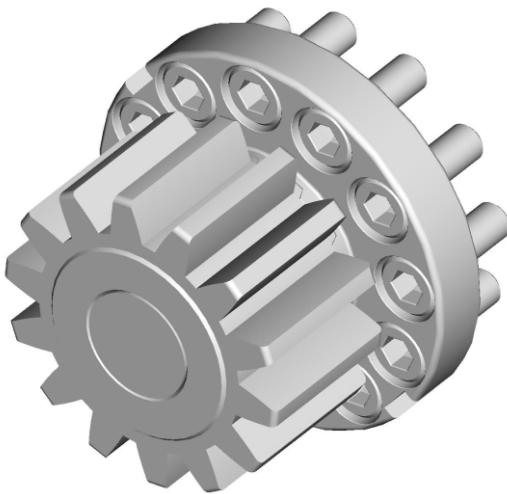

- In Table 2, the maximum permissible torque of the pinion Curvic Plate and the rack is calculated of the basis of a speed of 1.5 m/s and providing good lubrication (using an automatic lubrication system or manually applied grease every day), the tooth root strength factor $SF \geq 1.4$, tooth surface strength coefficient $SH \geq 1$, the safety factor $SB \approx 1$, and the required service life of 20,000 hours. By higher speed, the max. permissible torque reduced. The user needs to increase the safety factor for the application.
- Backlash changes by different center height. Please contact APEX under (WWW.APEXDYNA.COM).

■ Table 2. The max. permitted torque and feed-force of pinion Curvic Plate.

Mn [mm]	Z ⁽¹⁾ []	dw ⁽²⁾ [mm]	F _{2r} ⁽³⁾ [N]	T _{2B} ⁽⁴⁾ [Nm]
2	21	44	7,857	165
3	19	58	14,211	405
4	19	81.5	26,974	1,025
5	19	98	44,316	2,105
6	19	117	63,246	3,605
8	16	133	93,125	5,960
10	15	159	144,000	10,800

(1) Number of teeth (2) Working Pitch Circle Diameter (in mm) (3) Maximum Feed-Force

Selection of the optimum gearbox

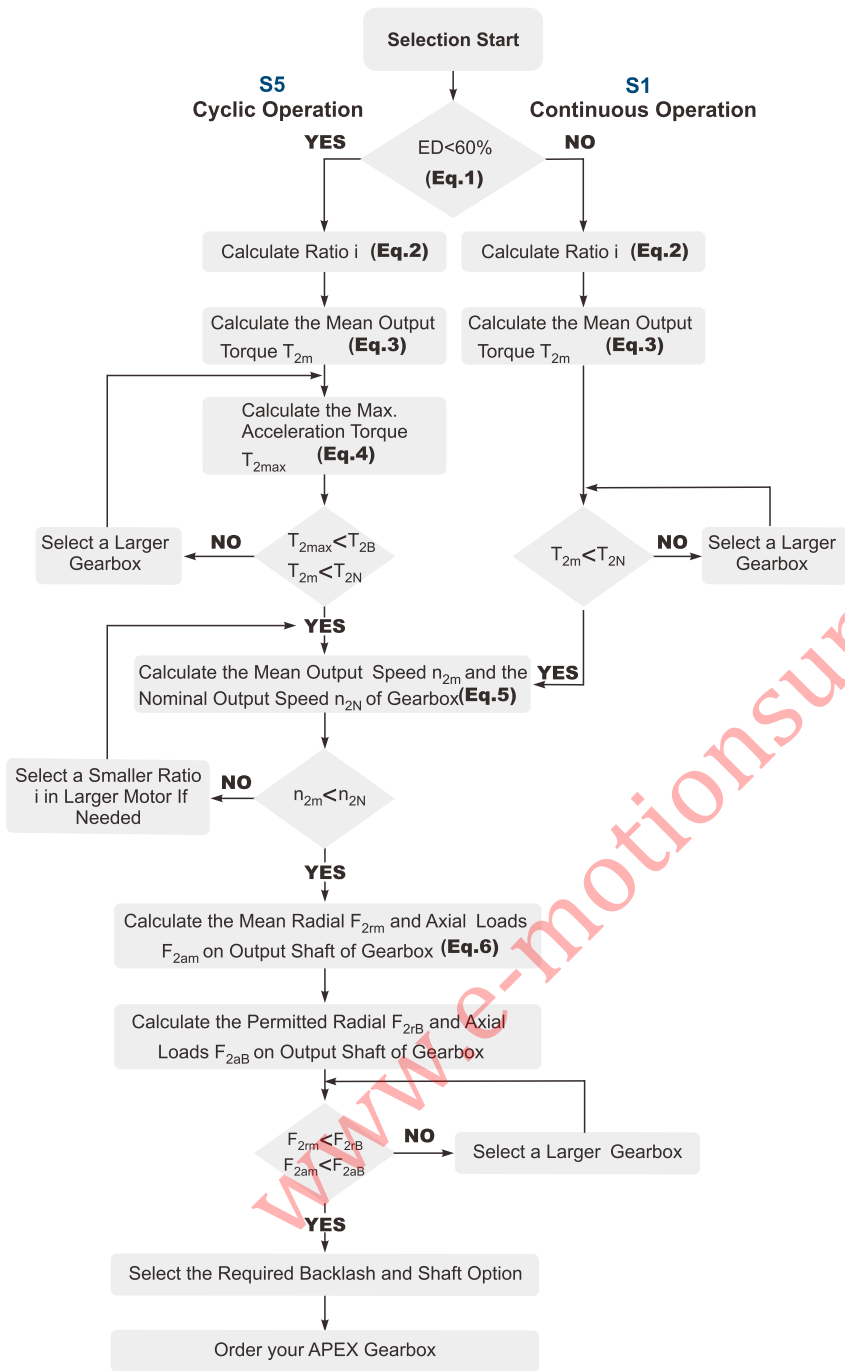

Recommended (for S5 Cycle Operation)

The general design is given for

$$\frac{J_L}{i^2} \leq 4 \times J_m$$

The optimal design is given for

$$\frac{J_L}{i^2} \cong J_m$$

J_L Load Inertia
 J_m Motor Inertia

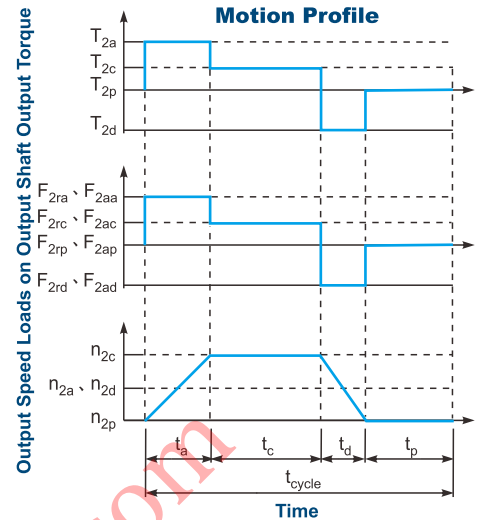

$$1. ED = \frac{t_a + t_c + t_d}{t_{cycle}} \times 100\% .$$

Index : a. Acceleration, c. Constant, d. Deceleration, p. Pause

(Eq.1)

$$2. i \cong \frac{n_m}{n_{work}}$$

n_m Output Speed of the Motor
 n_{work} Working Speed

(Eq.2)

$$3. T_{2m} = 3 \sqrt{\frac{n_{2a} \times t_a \times T_{2a}^3 + n_{2c} \times t_c \times T_{2c}^3 + n_{2d} \times t_d \times T_{2d}^3}{n_{2a} \times t_a + n_{2c} \times t_c + n_{2d} \times t_d}}$$

(Eq.3)

4. $T_{2max} = T_{mB} \times i \times K_s \times \eta$

where K_s is

K_s	No. of Cycles / hr
1.0	0 ~ 1,000
1.1	1,000 ~ 1,500
1.3	1,500 ~ 2,000
1.6	2,000 ~ 3,000
1.8	3,000 ~ 5,000

T_{mB} Max. Output Torque of the Motor
 η Efficiency of the Gearbox

(Eq.4)

$$5. n_{2a} = n_{2d} = \frac{1}{2} \times n_{2c}$$

$$n_{2m} = \frac{n_{2a} \times t_a + n_{2c} \times t_c + n_{2d} \times t_d}{t_a + t_c + t_d}$$

$$n_{2N} = \frac{n_{1N}}{i}$$

(Eq.5)

$$6. F_{2rm} = 3 \sqrt{\frac{n_{2a} \times t_a \times F_{2ra}^3 + n_{2c} \times t_c \times F_{2rc}^3 + n_{2d} \times t_d \times F_{2rd}^3}{n_{2a} \times t_a + n_{2c} \times t_c + n_{2d} \times t_d}}$$

$$F_{2am} = 3 \sqrt{\frac{n_{2a} \times t_a \times F_{2aa}^3 + n_{2c} \times t_c \times F_{2ac}^3 + n_{2d} \times t_d \times F_{2ad}^3}{n_{2a} \times t_a + n_{2c} \times t_c + n_{2d} \times t_d}}$$

(Eq.6)

Glossary

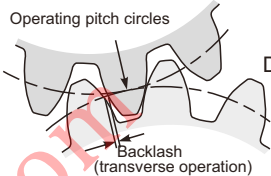
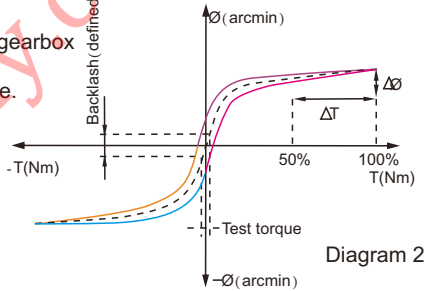
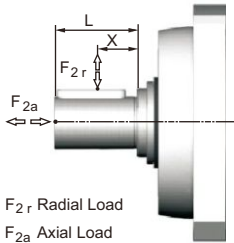
Emergency Stop Torque T_{2NOT}	Nm	The Emergency Stop Torque is the maximum permitted torque at the output of gearbox. This may happen only occasionally and may not exceed 1,000 times during the whole service life.
Max. Acceleration Torque T_{2B}	Nm	Under the Cyclic Operation (S5), the Max. Acceleration Torque is the maximum torque which can be transmitted only briefly to the output of gearbox up to 1,000 cycles/hr.
No Load Running Torque	Nm	The No Load Running Torque is the min. torque to overcome the internal friction of a gearbox without loading*.
Nominal Input Speed n_{1N}	rpm	The Nominal Input Speed is the permitted input speed of gearbox by the Continuous Operation (S1) while the housing temperature does not exceed 90°C. This value is measured at environment temperature 25°C.
Max. Input Speed n_{1B}	rpm	The Max. Input Speed is the max. permitted input speed of gearbox by the Cyclic operation (S5). This value is measured at environment temperature 25°C and serves as the absolute limit of the gearbox.
Backlash	arcmin	<p>The Backlash is the maximum angular measurement between two teeth of gears when the transverse operation occurs (refer to Diagram 1). The arcmin is the measurement unit for the backlash. One arcmin equals 1/60 degree, symbolized as 1'.</p>  <p style="text-align: right;">Diagram 1</p>
Torsional Rigidity	Nm/arcmin	<p>Torsional Rigidity is the quotient ($\Delta T / \Delta \varnothing$) between the applied torque and resulting torsion angle. This value indicates how much torque is needed on the gearbox to rotate the output shaft for 1 arcmin. The Torsional Rigidity can be determined by Hysteresis Curve.</p> <p>Hysteresis Curve When the input shaft is locked, increase torque at the output slowly up to T_{2B} in both directions and then release the torque gradually. According to the measured torque and torsion angle, a closed curve will be acquired as in the Diagram 2.</p>  <p style="text-align: right;">Diagram 2</p>
Radial Load And Axial Load	N	<p>The permitted radial and axial loads on output shaft of the gearbox depend on the design of the gearbox supporting bearings.</p> <p>For more information, please refer to APEX website.</p>  <p style="text-align: right;">F_{2r} Radial Load F_{2a} Axial Load</p>
Efficiency η	%	The transmission efficiency of the gears inside a gearbox (without friction).
Operating Temperature	°C	The Operating Temperature indicates the temperature of gearbox housing.
Degree of Protection		IP code stands for International Protection standard. The IP65 as example: the first IP number stands for protection degree against dust; the second IP number stands for protection against liquid.
Lubrication		APEX uses synthetic lubrication grease. Alternate greases are available, please contact APEX.
Running Noise	dB(A)	The Running Noise is measured depends on gearbox size, the ratio and the speed*. Higher speed usually induces higher noise level, while higher ratio induces lower noise level.
Moment of Inertia J_1	kg.cm ²	The Moment of Inertia J_1 is a measurement of the effort applied to an object to maintain its momentary condition at rest or rotating.
Breakaway Torque	Nm	The Breakaway Torque is the minimum torque to start the rotation from the input side of gearbox. A smaller size or a higher ratio gearbox requests less Breakaway Torque.
Back Driving Torque	Nm	The Back Driving Torque is the minimum torque to start the rotation from the output side of gearbox. A larger size or a higher ratio gearbox requires greater Back Driving Torque.

* This value is measured at environment temperature 25°C and the input speed 3,000 rpm. If the Nominal Input Speed n_{1N} of gearbox is lower than 3,000 rpm, this value is measured by that specific Nominal Input Speed.