

MAKING SMART
MACHINES **SMARTER**

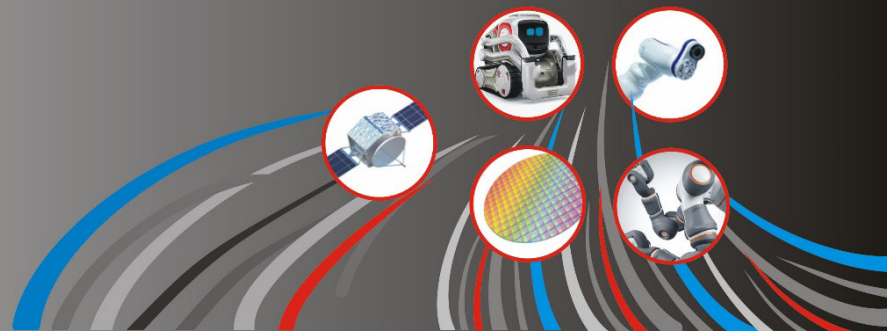

Gold Solo Triple Twitter Digital Servo Drive Installation Guide CAN and EtherCAT

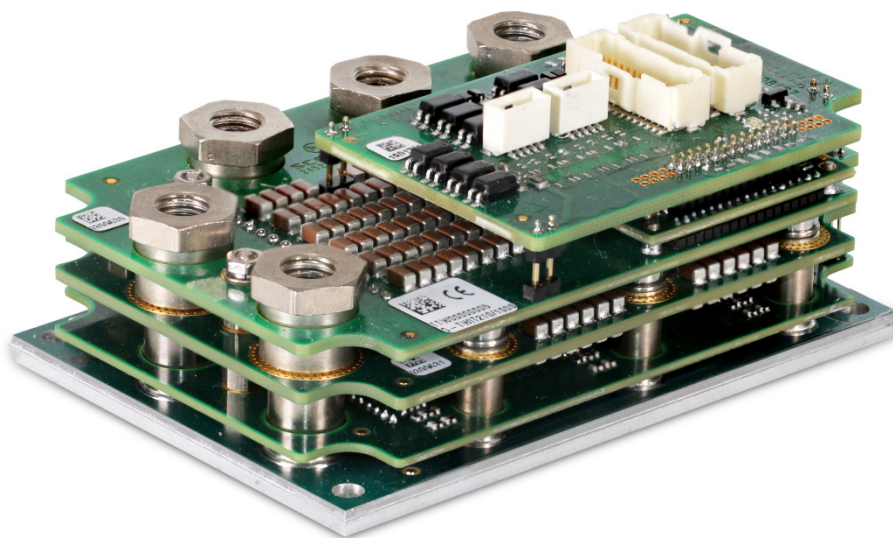

May 2022 (Ver. 1.009)

www.elmomc.com

Elmo
Motion Control

Notice

This guide is delivered subject to the following conditions and restrictions:

- This guide contains proprietary information belonging to Elmo Motion Control Ltd. Such information is supplied solely for the purpose of assisting users of the Gold Solo Triple Twitter servo drive in its installation.
- The text and graphics included in this manual are for the purpose of illustration and reference only. The specifications on which they are based are subject to change without notice.
- Information in this document is subject to change without notice.

Document no. MAN-G-SOLTTWI (Ver. 1.009)
 Copyright © 2022
 Elmo Motion Control Ltd.
 All rights reserved.

Catalog Number

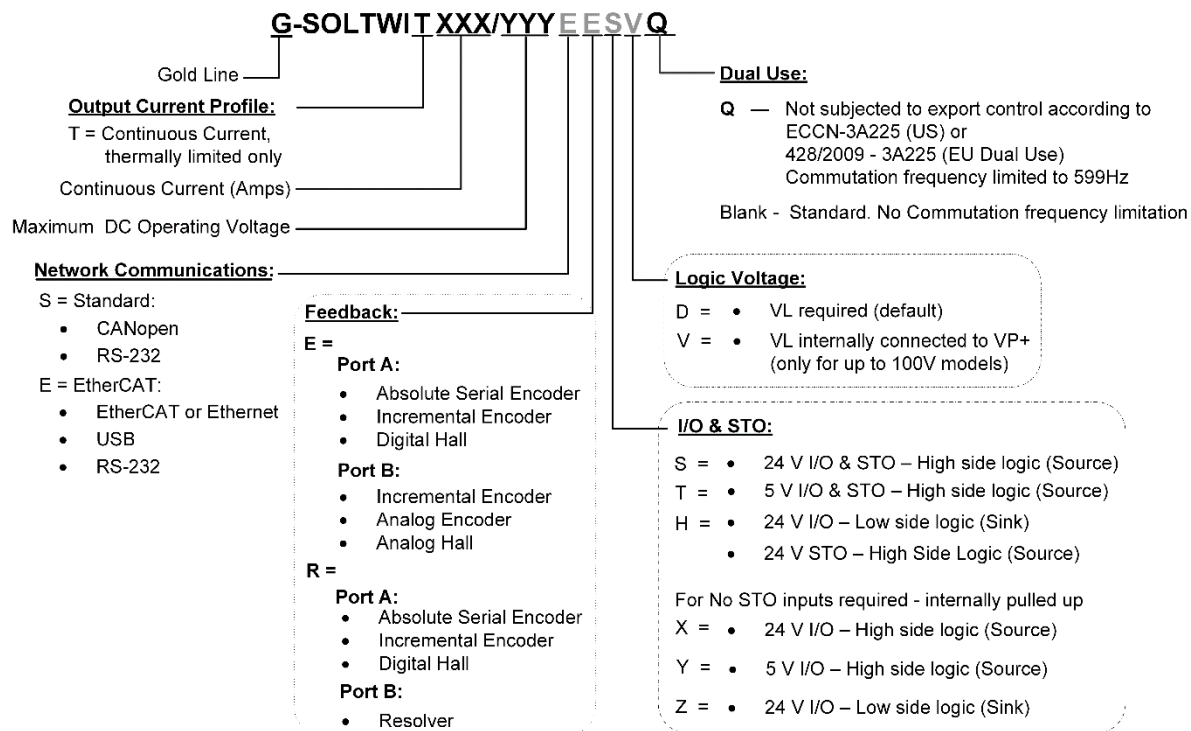

Revision History

Version	Date
Ver. 1.000	Feb 2020
Ver. 1.001	Jul 2020
Ver. 1.002	Dec 2020
Ver. 1.003	Jan 2021
Ver. 1.004	Mar 2021
Ver. 1.005	Sept 2021
Ver. 1.006	Nov 2021
Ver. 1.007	Mar 2022
Ver. 1.008	Apr 2022
Ver. 1.009	May 2022



- Chapter 1: This Installation Guide7**

- Chapter 2: Safety Information7**
 - 2.1. Warnings8
 - 2.2. Cautions.....8
 - 2.3. Warranty Information8

- Chapter 3: Product Description.....9**

- Chapter 4: Technical Information.....10**
 - 4.1. Physical Specifications.....10
 - 4.2. T Type Technical Data.....10
 - 4.3. Control Supply Input Voltage (VL).....11
 - 4.4. Product Features11
 - 4.5. Environmental Conditions.....12

- Chapter 5: Standards and Certifications13**
 - 5.1. Functional Safety13
 - 5.2. Electrical Safety13
 - 5.3. Electromagnetic Compatibility13
 - 5.4. Environmental14
 - 5.5. Other Compliant Standards.....14
 - 5.6. CE Declaration14
 - 5.7. Dual Use14

- Chapter 6: Installation.....15**
 - 6.1. Unpacking the Servo Drive Components.....15
 - 6.2. Mounting the Gold Solo Triple Twitter to a Heat Sink16
 - 6.3. The Gold Solo Triple Twitter Connection Diagrams17
 - 6.3.1. CAN Connection Diagram17
 - 6.3.2. EtherCAT Connection Diagram18

- Chapter 7: Wiring.....19**
 - 7.1. Wiring Legend.....19
 - 7.2. Connectors Types20
 - 7.2.1. Recommended Cable Lugs and Cabling.....21
 - 7.3. Mating Connectors, Wires, and Cables21
 - 7.4. Logic and Control Cabling and Wiring22
 - 7.4.1. J10 and J11 (Feedback ports, VL, RS232, USB, Analog Input).....22

7.4.2.	J11 (Digital Inputs/Outputs, STO).....	22
7.4.3.	J17, J18 EtherCAT or CAN Communication.....	22
7.4.4.	COMRET to PE Connection	22
7.5.	Wiring the Female Connectors.....	23
Chapter 8:	Connections	24
8.1.	Main, Control, and Motor Power	24
8.1.1.	Connecting the DC Power and the Motor Power Wires.....	24
8.1.2.	Motor Power Connections	26
8.1.3.	Motor Power	27
8.1.4.	Main Power and Control Supply.....	28
8.1.4.1.	Main Power	28
8.1.4.2.	Control Supply (J10).....	29
8.1.4.3.	Dual Power Supply (PN G-SOLTWITXXX/YYEESD).....	30
8.1.4.4.	Single Power Supply (PN G-SOLTWITXXX/YYEESV).....	32
8.2.	Drive Status Indicator	33
8.3.	J10 VL and Feedback Connector.....	34
8.3.1.	Port A.....	37
8.3.1.1.	Incremental Encoder	37
8.3.1.2.	Absolute Serial Encoder.....	38
8.3.1.3.	Hiperface	39
8.3.1.4.	Hall Sensors	39
8.3.2.	Port B.....	40
8.3.2.1.	Incremental Encoder	40
8.3.2.2.	Interpolated Analog Encoder	40
8.3.2.3.	Resolver	41
8.3.3.	Port C – Emulated Encoder Output (J10).....	41
8.4.	J11 I/O and Communication Connector	42
8.4.1.	Digital Inputs.....	45
8.4.1.1.	Source PLC Voltage Level Digital Input.....	45
8.4.1.2.	Sink PLC Voltage Level Digital Input	47
8.4.1.3.	Source 5V Logic Level Digital Input.....	49
8.4.2.	Digital Outputs.....	51
8.4.2.1.	Source PLC Voltage Level Digital Output.....	51
8.4.2.2.	Sink PLC Voltage Level Digital Output	53
8.4.2.3.	Digital Outputs Source 5V Logic Mode.....	55
8.4.3.	STO (Safe Torque Off).....	57

8.4.4.	Analog Input	58
8.4.5.	Standard RS-232	58
8.4.6.	USB 2.0 Communication (Only for EtherCAT version).....	59
8.5.	EtherCAT Communications Version	60
8.5.1.	EtherCAT IN/Ethernet Connector (J17)	60
8.5.2.	EtherCAT OUT Connector (J18)	61
8.5.3.	EtherCAT Option.....	62
8.5.3.1.	EtherCAT Communication	62
8.5.3.2.	EtherCAT Status Indicator (D2).....	63
8.5.3.3.	EtherCAT Link Indicators (D3, D4)	63
8.6.	CAN Communications Version	64
8.6.1.	CAN IN Connector (J17)	64
8.6.2.	CAN OUT Connector (J18).....	65
8.6.3.	CAN Option.....	66
8.6.3.1.	Interface	66
8.6.3.2.	CAN Layout	67
Chapter 9:	Powering Up	68
9.1.	Initializing the System	68
9.2.	Heat Dissipation	68
9.2.1.	Heat Dissipation Data	68
9.2.2.	How to Use the Chart	68
Chapter 10:	Dimensions	69
Chapter 11:	Cables and Accessories	71



Chapter 1: This Installation Guide

This installation Guide details the technical data, pinouts, and power connectivity of the Gold Solo Triple Twitter. For a comprehensive detailed description of the functions and connections of the drive, refer to the Gold Panel Mounted Drives Hardware Manual.

Chapter 2: Safety Information

In order to achieve the optimum, safe operation of the Gold Solo Triple Twitter, it is imperative that you implement the safety procedures included in this installation guide. This information is provided to protect you and to keep your work area safe when operating the Gold Solo Triple Twitter and accompanying equipment.

Please read this chapter carefully before you begin the installation process.

Before you start, ensure that all system components are connected to earth ground. Electrical safety is provided through a low-resistance earth connection.

Only qualified personnel may install, adjust, maintain and repair the servo drive. A qualified person has the knowledge and authorization to perform tasks such as transporting, assembling, installing, commissioning and operating motors.

The Gold Solo Triple Twitter contains electrostatic-sensitive components that can be damaged if handled incorrectly. To prevent any electrostatic damage, avoid contact with highly insulating materials, such as plastic film and synthetic fabrics. Place the product on a conductive surface and ground yourself in order to discharge any possible static electricity build-up.

To avoid any potential hazards that may cause severe personal injury or damage to the product during operation, keep all covers and cabinet doors shut.

The following safety symbols are used in this and all Elmo Motion Control manuals:



Warning:

This information is needed to avoid a safety hazard, which might cause bodily injury or death as a result of incorrect operation.



Caution:

This information is necessary to prevent bodily injury, damage to the product or to other equipment.



Important:

Identifies information that is critical for successful application and understanding of the product.

The following symbols are used in this document:



Note:

Information critical to the understanding and/or operating the feature.



Tip:

Information that helps understanding a feature, is good practice or a possible different way of action.



2.1. Warnings

- To avoid electric arcing and hazards to personnel and electrical contacts, never connect/disconnect the servo drive while the power source is on.
- Power cables can carry a high voltage, even when the motor is not in motion. Disconnect the Gold Solo Triple Twitter from all voltage sources before servicing.
- The high voltage products within the Gold Line range contain grounding conduits for electric current protection. Any disruption to these conduits may cause the instrument to become hot (live) and dangerous.
- After shutting off the power and removing the power source from your equipment, wait at least 3 minutes before touching or disconnecting parts of the equipment that are normally loaded with electrical charges (such as capacitors or contacts). Measuring the electrical contact points with a meter, before touching the equipment, is recommended.
- Control and communication circuits are separated from power circuits by only functional insulation. These circuits should be insulated according to the working voltage of the power circuit and the control or communication circuits based on the requirements of the end user application.

2.2. Cautions

- The maximum DC power supply connected to the instrument must comply with the parameters outlined in this guide.
- When connecting the Gold Solo Triple Twitter to an approved control supply, connect it through a line that is separated from hazardous live voltages using reinforced or double insulation in accordance with approved safety standards.
- Before switching on the Gold Solo Triple Twitter, verify that all safety precautions have been observed and that the installation procedures in this manual have been followed.
- Make sure that the Safe Torque Off is operational

2.3. Warranty Information

The products covered in this manual are warranted to be free of defects in material and workmanship and conform to the specifications stated either within this document or in the product catalog description. All Elmo drives are warranted for a period of 12 months from the time of shipment. No other warranties expressed or implied — and including a warranty of merchantability and fitness for a particular purpose — extend beyond this warranty.



Chapter 3: Product Description

The Ultra High Current Gold Solo Triple Twitter, which can deliver up to 270A @ up to 55VDC, 240A @ up to 75VDC, 210A @ up to 95VDC and 100A @ up to 195VDC, are advanced high power density servo drives, delivering up to **16 kW electrical power** in a compact (EtherCAT or CAN) package:

- EtherCAT: 55 x 80 x 34.7 mm (2.16" x 3.15" x 1.37") = 152.68 cm³ (9.32 in³)
- CAN: 55 x 80 x 32.8 mm (2.16" x 3.15" x 1.29") = 144.32 cm³ (8.78 in³)

This advanced, high power density servo drive provides top performance, advanced networking and built-in safety, as well as a fully featured motion controller and local intelligence. Power to the Gold Solo Triple Twitter is provided by a DC power source which is isolated from the Mains. The Gold Solo Triple Twitter can operate with single or dual power supplies. If separation between the main DC power source and a control supply is required, then a control supply (isolated from the Mains) is required according to the Part Number.

The drive can operate as a stand-alone device or as part of a multi-axis system in a distributed configuration on a real-time network.

The Gold Solo Triple Twitter drive is easily set up and tuned using the Elmo Application Studio (EASII) software tools. As part of the Gold product line, it is fully programmable with the Elmo motion control language. For more information about software tools refer to the Elmo Application Studio (EASII) User Guide.

The Gold Solo Triple Twitter is available in a variety of models. There are multiple power rating options, different communications options, a number of feedback options and different I/O configuration possibilities.

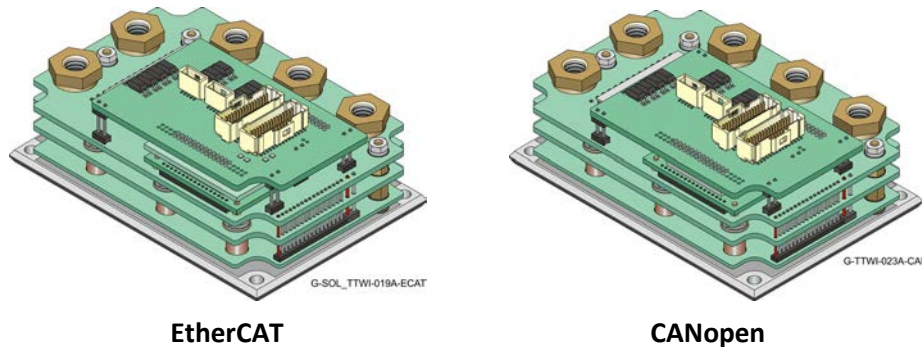

Figure 1: Difference between 4-Tier EtherCAT and 3-Tier CANopen modules



Chapter 4: Technical Information

4.1. Physical Specifications

Feature	Units	All Types
EtherCAT Version Weight	g (oz)	210.0 g (7.39 oz)
CAN Version Weight	g (oz)	205.0 g (7.22 oz)
EtherCAT Version Dimension	mm (in)	55 x 80 x 34.7 mm (2.16" x 3.15" x 1.37")
CAN Version Dimension	mm (in)	55 x 80 x 32.8 mm (2.16" x 3.15" x 1.29")
Mounting method		Panel Based Mounting

4.2. T Type Technical Data

Feature	Units	T270/60	T240/80	T210/100	T100/200
Minimum supply voltage	VDC	10			20
Nominal supply voltage	VDC	48	65	85	170
Maximum supply voltage	VDC	55	75	95	195
Maximum continuous Electrical power output	kW	12.5	15	17	16.5
Efficiency at rated power (at nominal conditions)	%	> 99			
Maximum output voltage		Up to 96% of DC bus voltage			
Amplitude sinusoidal continuous current	A	270	240	210	100
3-Phase Sinusoidal continuous RMS current limit (I _c)	A	190	170	150	70
Current limit	A	Max continuous Output current is guaranteed for T _{Heat-Sink} <85°C			



4.3. Control Supply Input Voltage (VL)

The Control Supply input voltage (VL) must be either SELV or PELV rated.

Feature	Unit	Details
Standard CAN (S option)		
Input range	V	12 V – 95 V
Power consumption (including 5 V/200 mA for encoder)	W	< 2.5 W
ETHERCAT (E option)		
Input range	V	12 V – 95 V
Power consumption (including 5 V/200 mA for encoder)	W	< 4 W

4.4. Product Features

Main Feature	Details	Presence / No.
STO	+5V Logic, Opto isolated from the Control section, <i>or</i>	✓
	PLC Source, Opto isolated from the Control section	✓
Digital Input	+5V Logic, Opto isolated from the Control section <i>or</i>	6
	PLC Source, Opto isolated from the Control section <i>or</i>	6
	PLC Sink Opto isolated from the Control section	6
Digital Output	+5V Logic, Opto isolated from the Control section <i>or</i>	4
	PLC Source, Opto isolated from the Control section <i>or</i>	4
	PLC Sink, Opto isolated from the Control section	4
Analog Input	Differential ±10V or Single Ended	1
Feedback	Standard Port A, B, and C	✓
Communication Option	USB (only for EtherCAT version)	✓
	EtherCAT <i>or</i>	✓
	CAN	✓
	Standard RS232	✓



4.5. Environmental Conditions

You can guarantee the safe operation of the Gold Solo Triple Twitter by ensuring that it is installed in an appropriate environment. The following table describes the certified environmental conditions for STO of the Gold series servo drives.



Warning: During operation the Gold Solo Triple Twitter becomes hot to the touch (the heatsink and wires may heat up to 92 °C). Care should be taken when handling it.



Caution: The Gold Solo Triple Twitter dissipates its heat by convection or by conduction. The maximum ambient operating temperature of 50 °C (122°F) must not be exceeded.

Feature	Details
Operating ambient temperature	0 °C to +50 °C (32 °F to +122 °F)
Storage temperature	-40 °C to +85 °C (-40 °F to +185 °F)
Maximum non-condensing humidity according to IEC60068-2-78	95%
Maximum Operating Altitude	2,000 m (6562 feet) It should be noted that servo drives capable of higher operating altitudes are available on request.
Mechanical Shock according to IEC60068-2-27	15g / 11ms Half Sine
Vibration according to IEC60068-2-6	5 Hz ≤ f ≤ 10 Hz: ±10mm 10 Hz ≤ f ≤ 57 Hz: 4G 57 Hz ≤ f ≤ 500 Hz:5G



Chapter 5: Standards and Certifications

5.1. Functional Safety

Standard	Item
IEC 61800-5-2:2017	Adjustable speed electrical power drive systems – Safety requirements – Functional
EN ISO 13849-1:2015	Safety of machinery — Safety-related parts of control systems.
EN 61508-1:2010	Functional safety of electrical/electronic/programmable electronic safety-related systems
EN 61508-2:2010	Functional safety of electrical/electronic/programmable electronic safety-related systems
EN 61508-3:2010	Functional safety of electrical/electronic/programmable electronic safety-related systems

5.2. Electrical Safety

Specification	Details
Recognized UL 61800-5-1	Adjustable speed electrical power drive systems: Safety requirements – Electrical, thermal and energy
CSA C22.2 NO. 274-17	Adjustable speed drives

5.3. Electromagnetic Compatibility

Specification	Details
EN 61800-3:2004/A1:2011	Adjustable speed electrical power drive systems Part 3: EMC requirements and specific test methods
EN 61800-5-2: 2017 Annex E	Adjustable speed electrical power drive systems Part 5-2: Safety requirements – Functional



5.4. Environmental

Specification	Details
IEC60068-2-78	Damp heat, steady state
IEC60068-2-6	Vibration (sinusoidal)
IEC60068-2-2	Dry heat
IEC60068-2-27	Shock

5.5. Other Compliant Standards

For other compliant standards refer to the

[MAN-G-Board Level Modules Hardware Manual section 17.7](#) or refer to the Elmo website:

<https://www.elmomc.com/capabilities/standards-compliance/gold-family/>

5.6. CE Declaration

Refer to the complete EC Declaration of Conformity available on the internet at:

https://www.elmomc.com/wp-content/uploads/dlm_uploads/2018/05/Gold-Line-CE-Declaration-of-Conformity.pdf.

5.7. Dual Use

No export license is required for the Gold Line products signified with the suffix Q in the Part Number.

The operating frequency of the Gold Line products is “factory limited” to ≤ 599 Hz, and therefore complies with the EU Dual Use Regulation 428/2009, 3A225, and the US Dual Use regulation EAR ECCN# 3A225.

This statement applies to all identical specimens and will become invalid if a change is made in the firmware.



Chapter 6: Installation

6.1. Unpacking the Servo Drive Components

Before you begin working with the Gold Solo Triple Twitter, verify that you have all of its components, as follows:

- The Gold Solo Triple Twitter servo drive
- The Elmo Application Studio (EASII) software and software manual

The Gold Solo Triple Twitter is shipped in a cardboard box with Styrofoam protection.

To unpack the Gold Solo Triple Twitter:

1. Carefully remove the servo drive from the box and the Styrofoam.
2. Check the drive to ensure that there is no visible damage to the instrument. If any damage has occurred, report it immediately to the carrier that delivered your drive.
3. To ensure that the Gold Solo Triple Twitter you have unpacked is the appropriate type for your requirements, locate the part number sticker on the top of the Gold Solo Triple Twitter. It looks like this:



4. Verify that the Gold Solo Triple Twitter type is the one that you ordered, and ensure that the voltage meets your specific requirements.
The part number at the top provides the type designation. Refer to the appropriate part number in the section Catalog Number at the beginning of the installation guide.



6.2. Mounting the Gold Solo Triple Twitter to a Heat Sink

The selected heat sink must be screwed to the lower surface of the Gold Solo Triple Twitter.

To mount the heat sink:

1. Mount the heat sink under the base of the Gold Solo Triple Twitter.
2. Place the Thermal foil (Part No. IMT-TTWIALH purchased from Elmo) between the lower surface of the servo drive, and the upper surface of the heat sink
3. Use four M3 head cup Allen screws to secure the heat sink under the servo drive.
4. Tighten the screws to the relevant torque force applicable to an M3 stainless steel A2 screw.

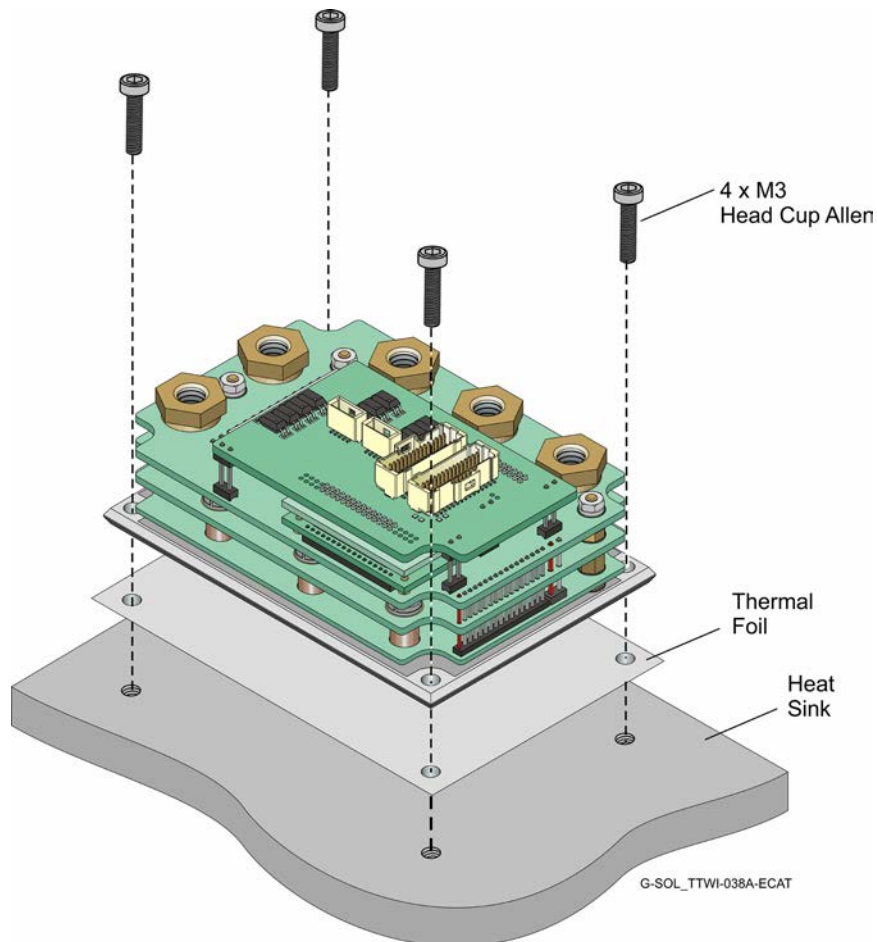
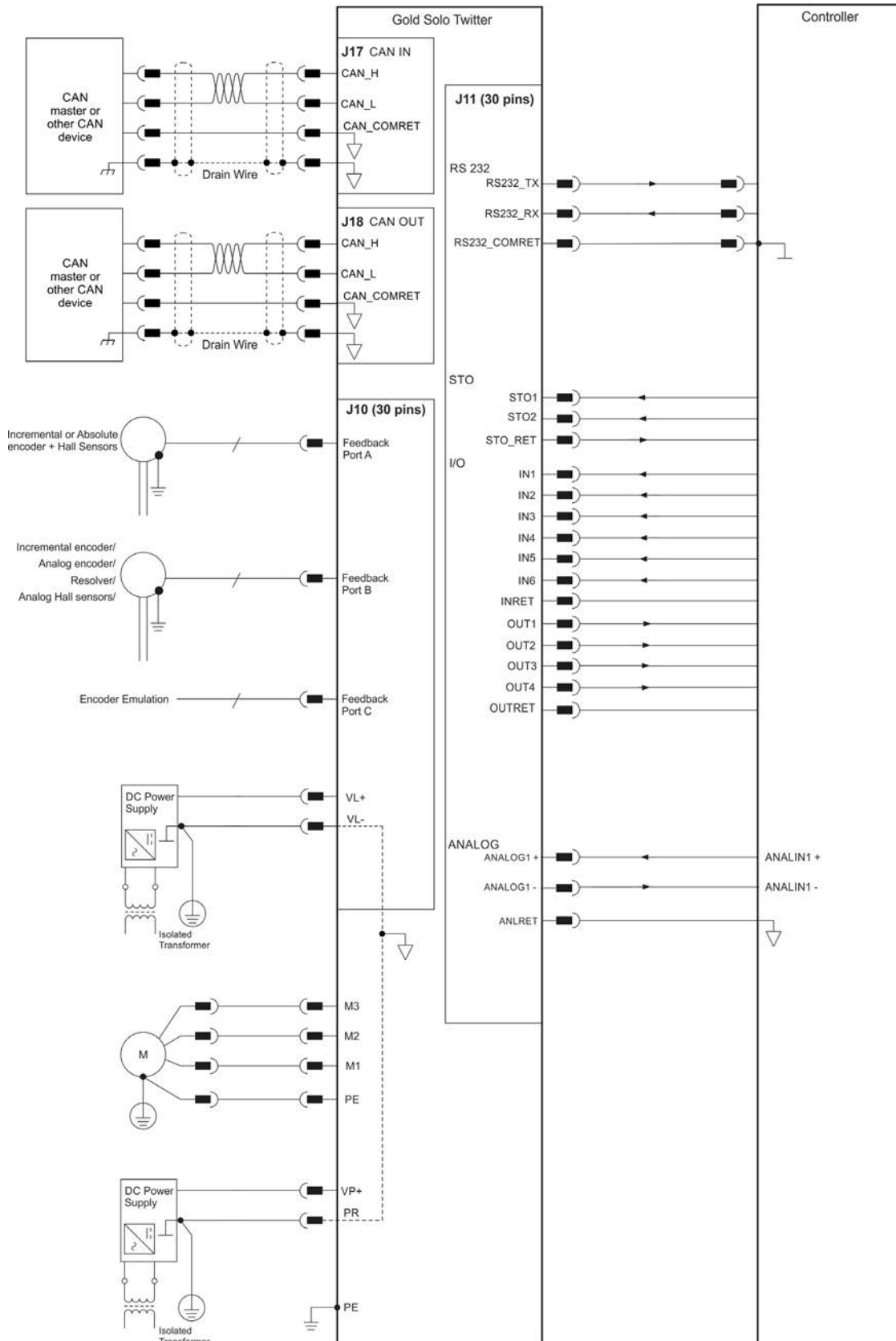

Figure 2: Mount the Heat Sink and Thermal Foil to the Gold Solo Triple Twitter



6.3. The Gold Solo Triple Twitter Connection Diagrams

6.3.1. CAN Connection Diagram



G-SOL_TTWI_CAN-F

Figure 3: The Gold Solo Triple Twitter CAN Connection Diagram



6.3.2. EtherCAT Connection Diagram

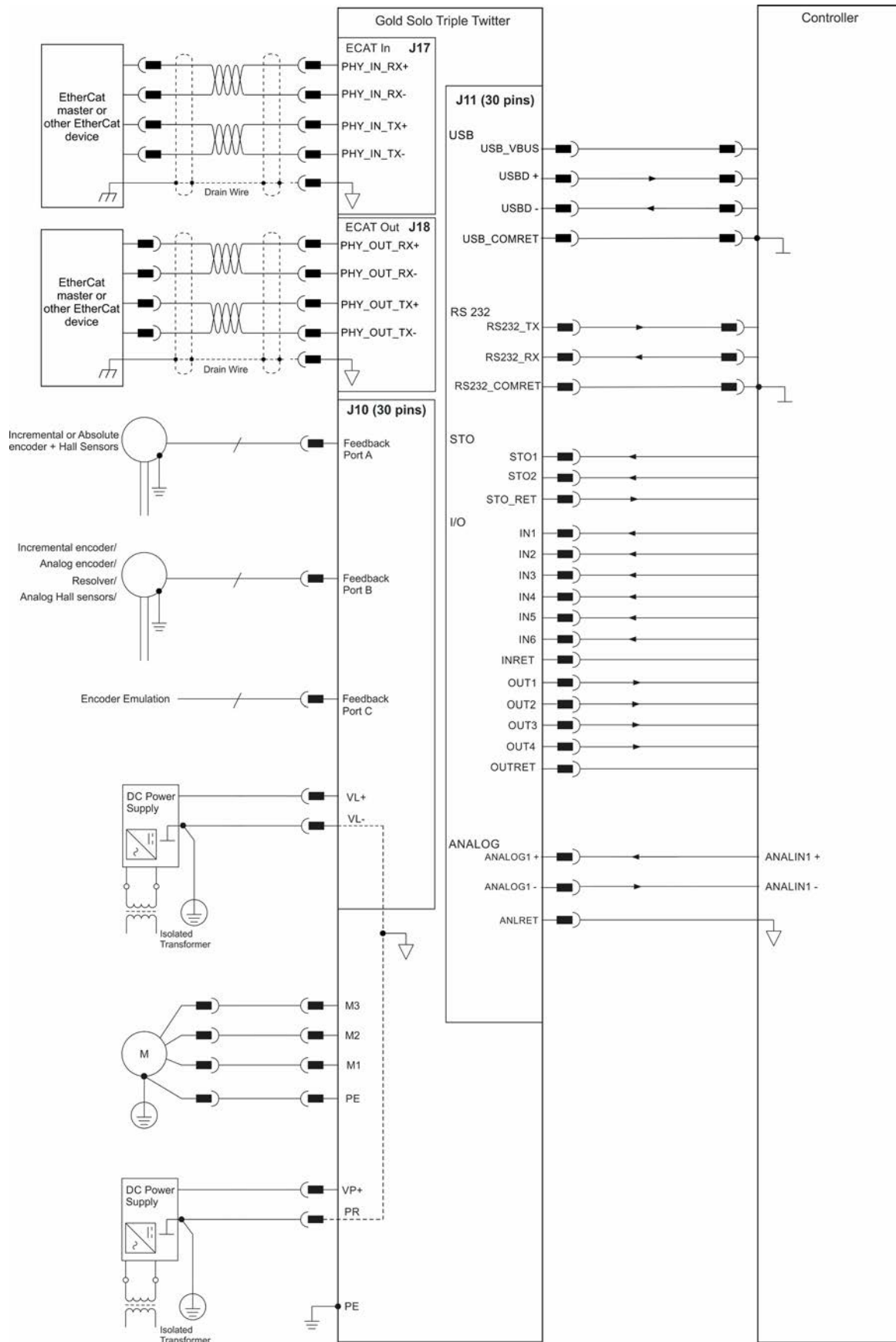

G-SOL_TTWI-001A

Figure 4: The Gold Solo Triple Twitter EtherCAT Connection Diagram



Chapter 7: Wiring

7.1. Wiring Legend

The following table legend describes the wiring symbols detailed in all installation guides.

Wiring Symbol	Description
 GGEN_101D-A	Earth connection (PE)
 GGEN_101D-B	Protective Earth Connection
 GGEN_101D-C	Common at the Controller
 GGEN_101D-D	Shielded cable with drain wire. The drain wire is a non-insulated wire that is in direct contact with the braid (shielding). Shielded cable with drain wire significantly simplifies the wiring and earthing.
 GGEN_101D-E	Shielded cable braid only, without drain wire.
 GGEN_101D-F	Twisted-pair wires

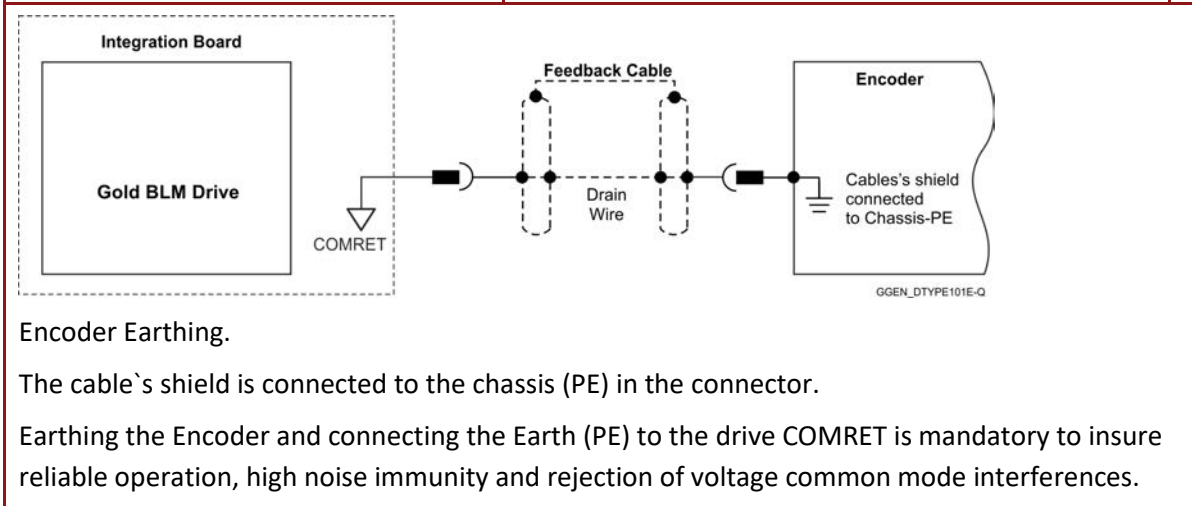



7.2. Connectors Types

The Gold Solo Triple Twitter has the following types of connectors.

Type	Function	Port	Connector Location
Terminal Lug + M6 Flat Washer + M6 Spring Washer + M6 x10 Screw	Power	VP+, PR	
	Motor	M1, M2, M3	
+ M3 Flat Washer + M3 Spring Washer + M3 Screw	Earth Connection	PE, PE PE, PE	

Recommended for M6 screw

Terminal Lug (FLEX) Stud hall size: M6

Connectors Location

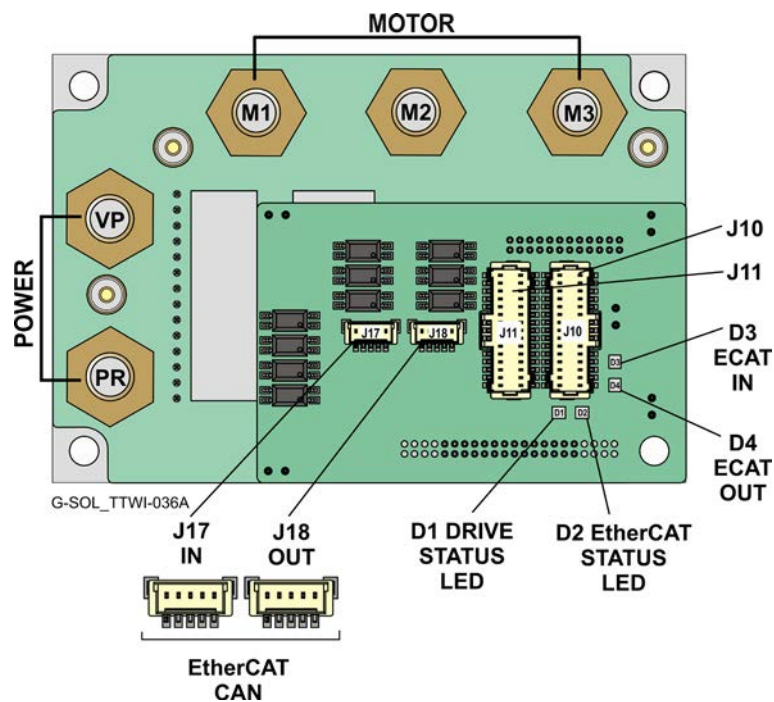

Pins	Type	Function
M6/10 depth	Redcube Terminal screw, M6 Flat Washer, M6 Spring Washer and M6/10 screw	Power, Motor
2 rows x 15 Pins	Molex type	J10 - VL & Feedback Ports
2 rows x 15 Pins	Molex type	J11 - IO and Communication



EtherCAT/CAN		
5	Molex type	J17 - CAN/EtherCAT IN Communication
5	Molex type	J18 - CAN/EtherCAT OUT Communication

7.2.1. Recommended Cable Lugs and Cabling

Elmo recommends the following cable lugs for motor and power depending on the cable to be installed. Refer to the specification drawings for the UL listed lug and cable application.

Copper Lug - One-Hole, Standard Flex Barrel

Current (A) (Up to)	Wire Type	Stud Size
270	#4 AWG	M6 (or ¼")
100	#8 AWG	M6 (or ¼")

For best noise immunity, twist the DC power wires. Do not twist or bundle the motor phase wires.

7.3. Mating Connectors, Wires, and Cables

Connector	Mating Connector Type	Mating Crimping Pins
J10, J11 VL & Feedback Ports IO and Communication	MOLEX 1.00mm "Pico-Clasp" 501189-3010	MOLEX 1.00mm crimp terminal 501193-3000
J17, 18 IN/OUT CAN/EtherCAT Communication	MOLEX 1.00mm "Pico-Clasp" 501330-0500	MOLEX 1.00mm crimp terminal 501334-0100



7.4. Logic and Control Cabling and Wiring

7.4.1. J10 and J11 (Feedback ports, VL, RS232, USB, Analog Input)

For short distances between the drive and control, 0.5 to 1.0 m wires can be used and shielding is not required. For longer distances than 1.0 m and/or high EMI environment, shielded and twisted wires should be used. Drain wires should be connected to Elmo COMRET.

7.4.2. J11 (Digital Inputs/Outputs, STO)

Wires can always be used, no need for twisting, no need for shielding.

7.4.3. J17, J18 EtherCAT or CAN Communication

Always use CAT5e cables

(see Elmo's Gold Solo Double Twitter Cable Kit (MAN-G-SOLO_DOUBLE_TWITTER_CBLKIT)).

7.4.4. COMRET to PE Connection

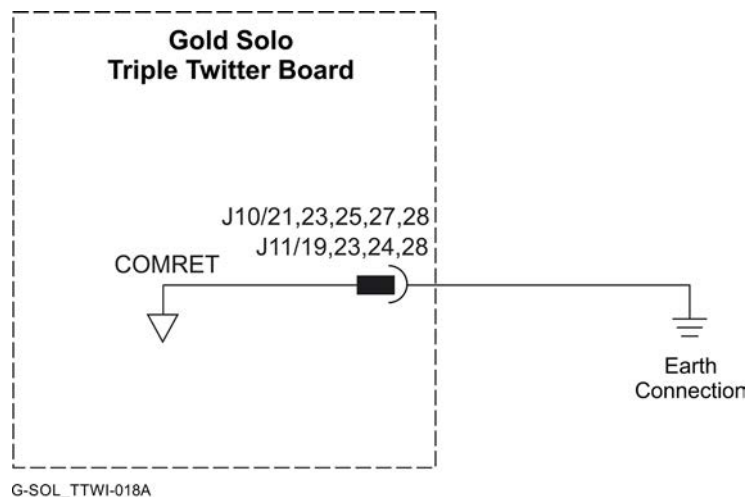

Figure 5: COMRET Connection to the PE

At least one COMRET pin (Figure 5) must be connected to the Protective Earth (PE).

Earthing the COMRET by connecting the Earth (PE) to the drive COMRET is mandatory to insure reliable operation, high noise immunity and rejection of voltage common mode interferences.



7.5. Wiring the Female Connectors

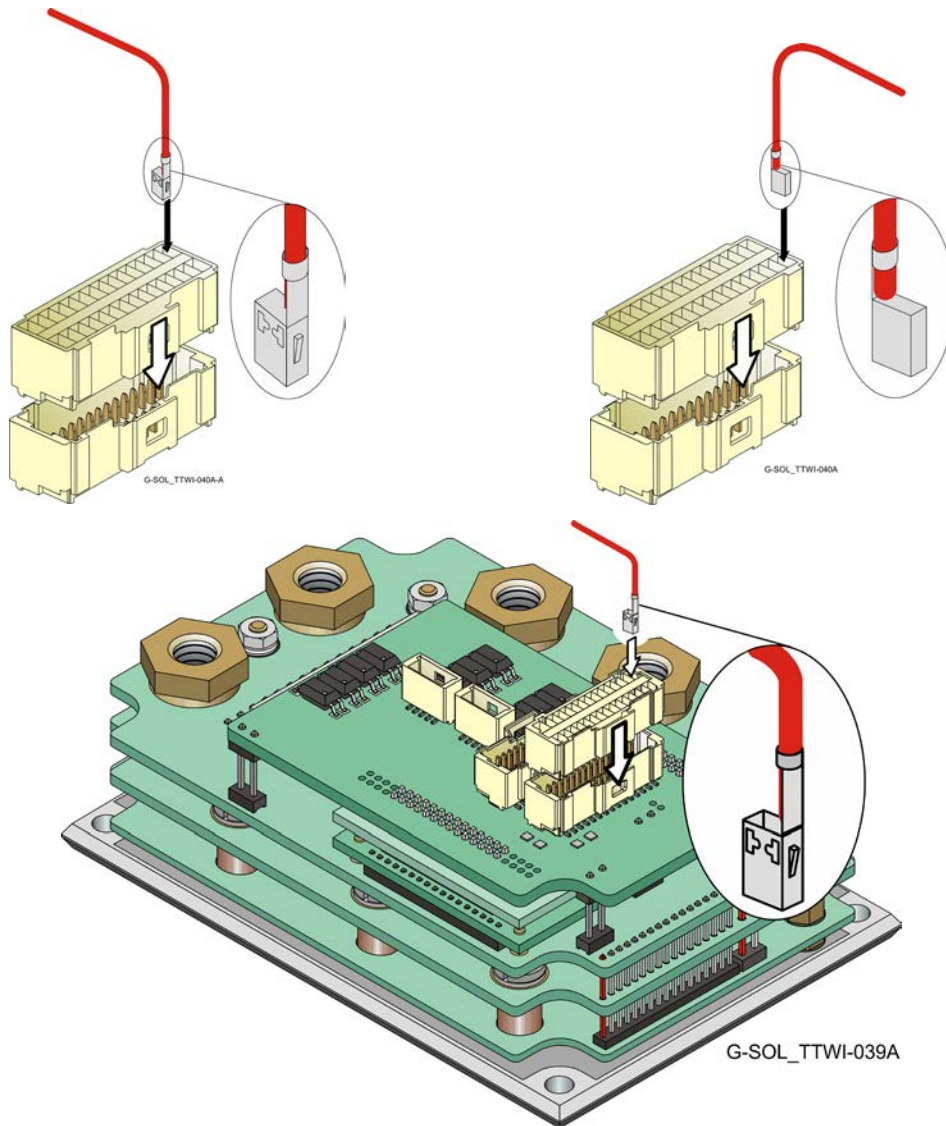

Figure 6: Inserting a wire/pin to the Female Connector

To insert a wire/pin to the female connectors of J10, J11, J17, and J18 do the following:

1. Select the relevantly colored wire to insert to a specific rectangular compartment on the female connector.
2. Use the appropriate Molex crimping plier (Molex P/N 63819-1500) to fasten a pin connector to the end of the wire.
3. Place the connector on a flat surface, in the orientation as shown in Figure 6. Notice that the rectangular slot has a niche at the bottom of the slot.
4. Insert the wire connector to the slot as shown in Figure 6. Make sure that the connector protrusion is inserted to the bottom of the rectangular slot. When inserting the wire connector to a slot in the second row, make sure to rotate the connector in the opposite orientation.
5. Repeat the same procedure for any other wire connections.



Chapter 8: Connections

8.1. Main, Control, and Motor Power

This section describes the Main and Control supplies, and Motor Power connections. The Motor and Main Power interface uses lugs and cables defined in section 7.2.1 Recommended Cable Lugs and Cabling.

8.1.1. Connecting the DC Power and the Motor Power Wires

This section describes the installation of the wire terminal lugs for both the Main Power wires to VP+, PR, and PE terminals on the Gold Solo Triple Twitter, and the Motor Power wires to the M1, M2, M3, and PE terminals on the Gold Solo Triple Twitter.



Note:

When connecting several identical motors, all the motor phases must be connected in an identical sequence in order to save repetition of the tuning process.

Step 1: PE Earth Connection

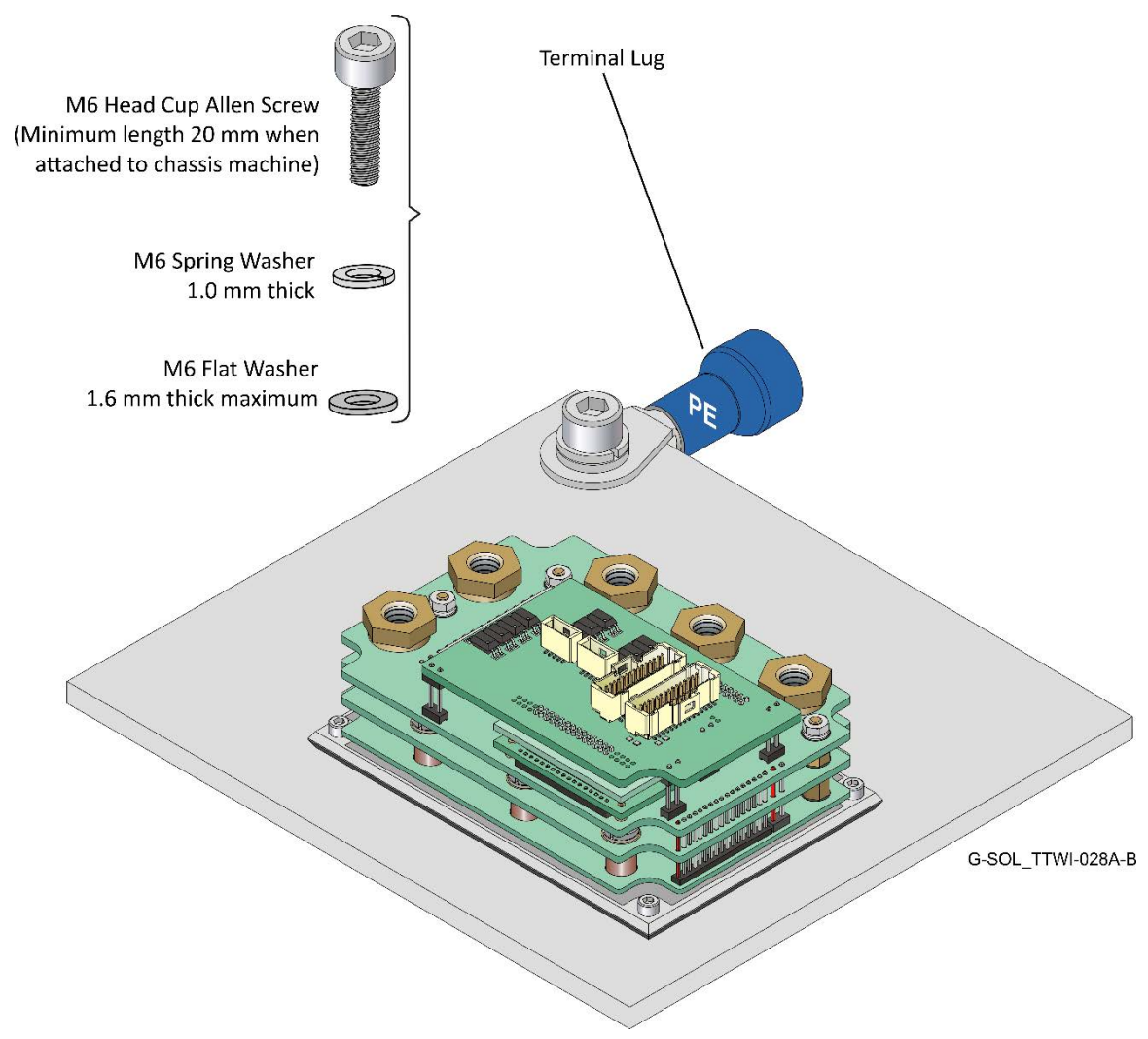

The required M6 screw torque is typically 2 Nm.



Step 2: Power and Motor Connection

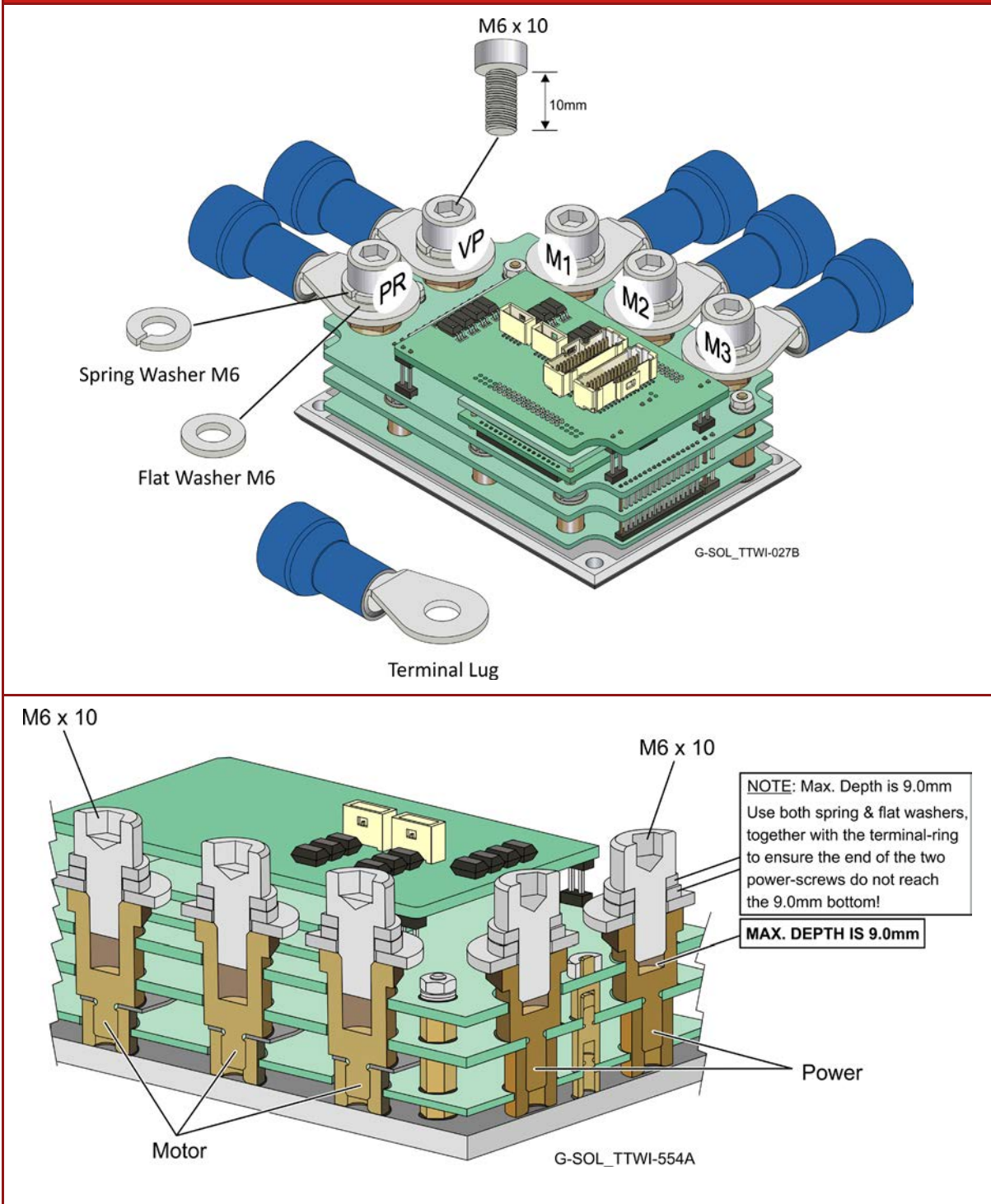

Table 1: Connecting the Main Power and Motor Cables



8.1.2. Motor Power Connections

1. Ensure that the motor chassis is properly earthed.
2. Connect the appropriate terminal lugs from the Motor Power cables to the M1, M2, M3, and PE terminals on the Gold Solo Triple Twitter.

The phase connection is arbitrary as Elmo Application Studio (EAS II) will establish the proper commutation automatically during setup. When tuning a number of drives, you can copy the setup file to the other drives and thus avoid tuning each drive separately. In this case the motor-phase order must be the same as on the first drive.

- a. Install the motor cables to the drive using the recommended Terminal Lug (FLEX), M6 flat washer, M6 spring washer, and secure with an M6/10 head cup Allen screw (to the drive). The required M6/10 screw torque is typically 2 Nm.
Make sure that the screws do not insert to the maximum depth of 9.0 mm as shown in Table 1 above.
 - b. Install the recommended PE wire to the drive, using the recommended Terminal Lug (FLEX), M6 flat washer, M6 spring washer, and secure with an M6/10 head cup Allen screw (to the drive). The required M6/10 screw torque is typically 2 Nm.
3. For high EMI environment, it is highly recommended to use a 4-wire shielded (not twisted) cable for the motor connection. The gauge is determined by the actual RMS current consumption of the motor.

Connect the cable shield to the closest ground connection at the motor end.

For better EMI performance, the shield should be connected to Earth Connection (heat sink mounting holes).



8.1.3. Motor Power

For full details see Section 7.3 in the manual: MAN-G-Board Level Modules Hardware manual.

Pin	Function	Cable		Pin Positions
		Brushless Motor	Brushed DC Motor	
PE	Connection earth	Motor	Motor	
M1	Motor phase	Motor	N/C	
M2	Motor phase	Motor	Motor	
M3	Motor phase	Motor	Motor	

Table 2: Motor Terminals

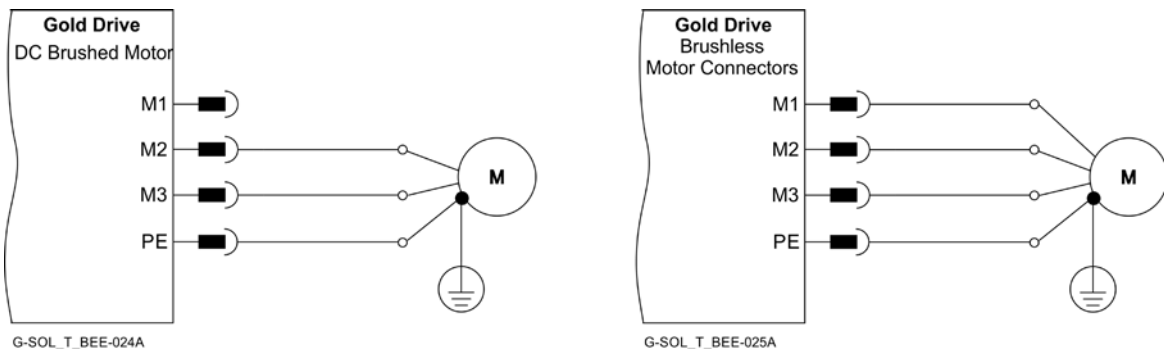

Figure 7: Brushed and Brushless Motor Power Connection Diagram

Connect the motor power wires as shown in Figure 8. The Yellow wire is the Grounding wire. Make sure not to bundle the wires.

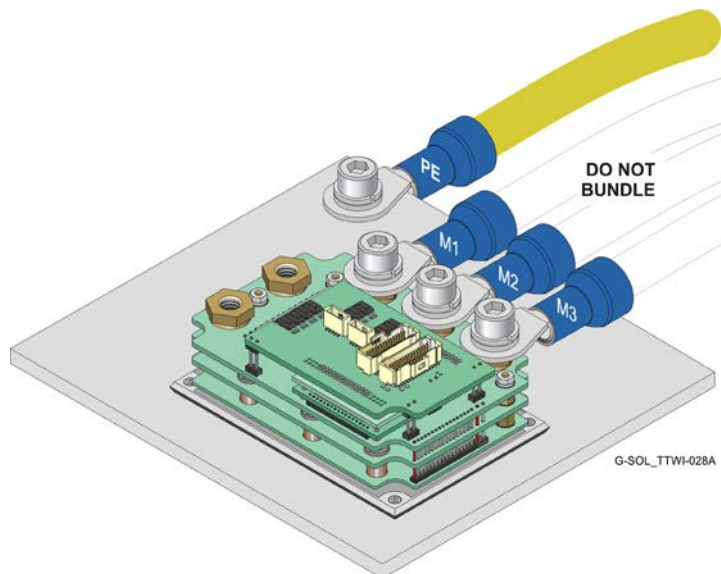

Figure 8: Connecting the Motor Power Wires



8.1.4. Main Power and Control Supply

This section describes the Main Power and the Control supply connector.

8.1.4.1. Main Power

The isolated DC power source is not included with the Gold Solo Triple Twitter.

Pin	Function	Cable	Pin Positions
VP+	DC Pos. Power input	Power	
PR	Power return	Power	
PE	Connection earth	Power	

Table 3: Main Power Terminals

Connect the DC power cable to the VP+ and PR terminals on the main power connector.

To connect the Gold Solo Triple Twitter to the DC power source:

1. The source of the VDC power supply must be isolated from the Mains.
2. Verify that the rectified VDC is indeed within the range of the drive.
3. Connect the VP+ and PR wires to the terminals on the servo-drive as shown in Figure 9. It is highly recommended to twist the two DC main power cables at intervals of 10 cm.

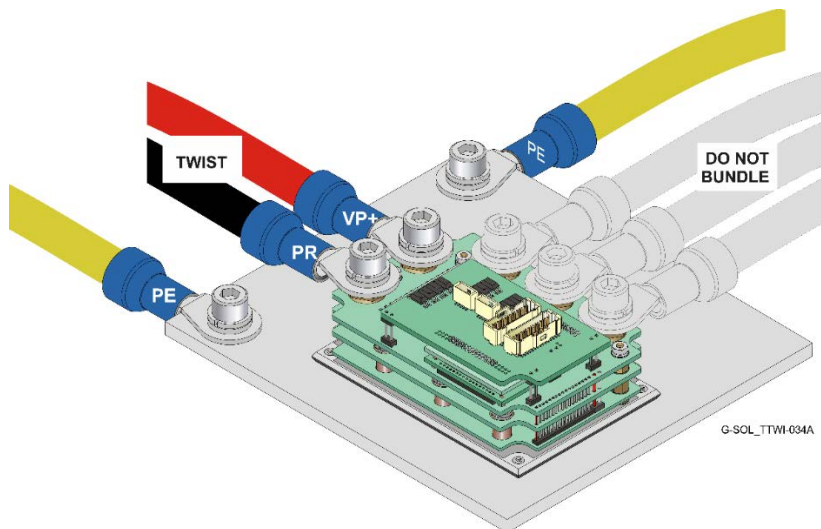

Figure 9: Connecting the Main Power Wires

4. Connect the PE to the closest earth connection near the power supply.
5. Connect the PR to the closest earth connection near the power supply.
6. Before applying power, first verify the polarity of the connection.



8.1.4.2. Control Supply (J10)

Connect the VL+ and VL- pins on the Gold Solo Triple Twitter in the manner described in the table and drawing below.

Pin	Signal	Function	Pin Positions
30	VL+	Control Supply Input	
29	VL-	Control Supply Return	
<ol style="list-style-type: none"> Standard CAN (S option) Input range: 12VDC – 95VDC Power consumption: < 2.5W (including 5 V/200 mA for encoder) EtherCAT (E option) Input range: 12VDC – 95VDC Power consumption: < 4W (including 5 V/200 mA for encoder) 			

Table 4: Control Supply Pins

Connect the VL+ and VL- terminals to the power supply Control Connector.

To connect the VL+ and VL- to the control supply:

- The source of the control supply must be isolated from the Mains.
- Connect the return (common) of the control supply source to the closest earth connection near the control supply source.
- Connect the VL+ and VL- wires to the terminals on the servo-drive as shown in Figure 10.

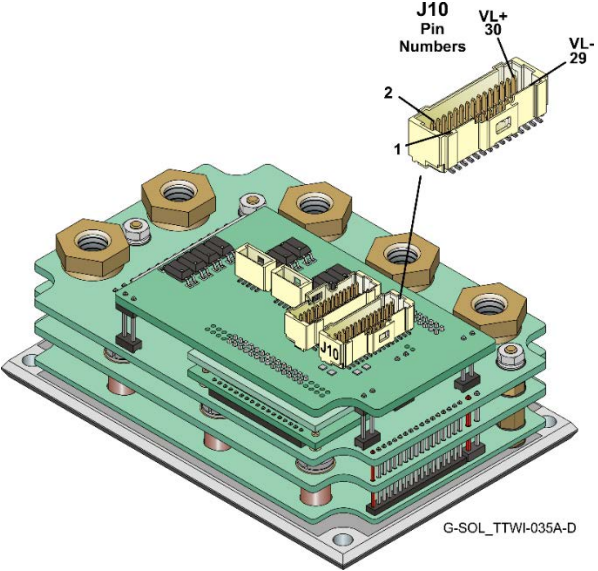
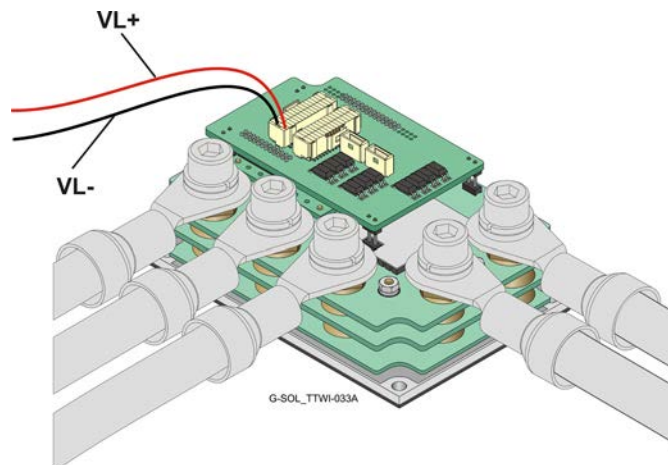

Figure 10: Connecting the Control Supply Wires

For short distances between the drive and control, 0.5 to 1.0 m wires can be used and shielding is not required. For longer distances than 1.0 m and/or high EMI environment, shielded and twisted wires should be used. Drain wires should be connected to Elmo COMRET.

- Before applying power, first verify the polarity of the connection.



8.1.4.3. Dual Power Supply (PN G-SOLTWITXXX/YYYYEESD)

Whenever dual power supply is selected by its part number, a separate supply for the Logic is required. Both the Power and Logic supplies are required to be isolated from the mains:

- A battery or main DC power source rectified from the mains, according to specification
- A control supply for the logic (VL+, VL-)

The following figure describes an ordinary power supply for Servo drives with sufficient internal capacitance and shunt regulator to manage power flow in both directions to-and-from the motor.



Note:

The PR, COMRET, and VL- are connected internally in the Gold Solo Triple Twitter.

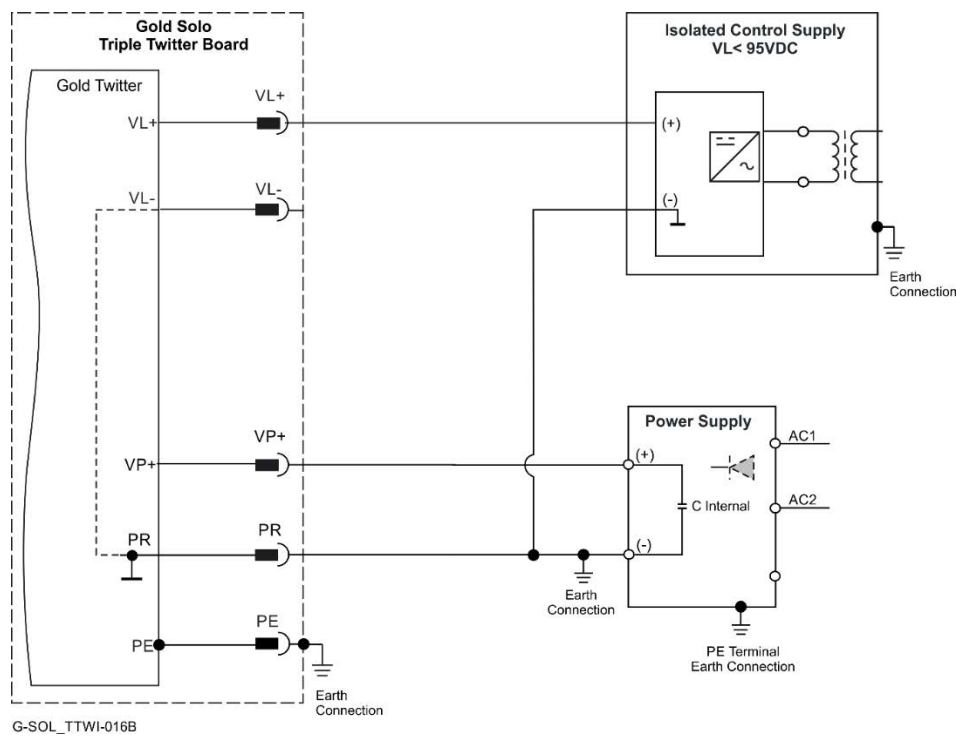

Figure 11: Separate VP and VL Power Supplies Connection Diagram –Highly Recommended

The (+) of the control power supply is connected to the VL+ terminal, while the (-) of the control power supply is connected directly to the (-) of the DC bus power supply. This connection avoids high current ground loops due to poor wiring (Figure 11).

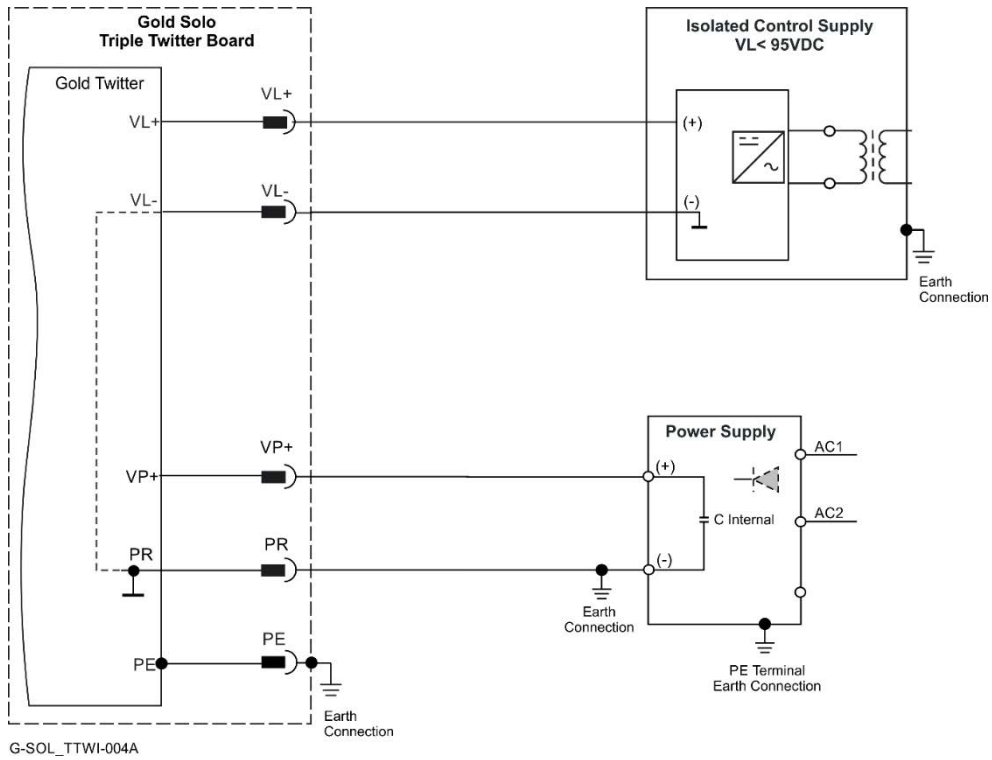

Figure 12: Separate VP and VL Power Supplies Connection Diagram - Alternative

The (-) of the control power supply is connected to the VL- of the Gold Solo Triple Twitter (Figure 12).



8.1.4.4. Single Power Supply (PN G-SOLTTWITXXX/YYYYEESV)

The Gold Solo Triple Twitter 80V and 100V can be ordered (with V suffix) with VL+ already internally connected to the VP+.

The single power supply is selected by its part number (VL+ connected to VP+) which describes the absolute maximum VP+ and VL+ voltage which must be < 95VDC, under all conditions, to prevent VL+ supply failure.

A single power supply can be used for the main and control power in the range of 12VDC to 95VDC.

The following figure describes a single connection of main power and control:

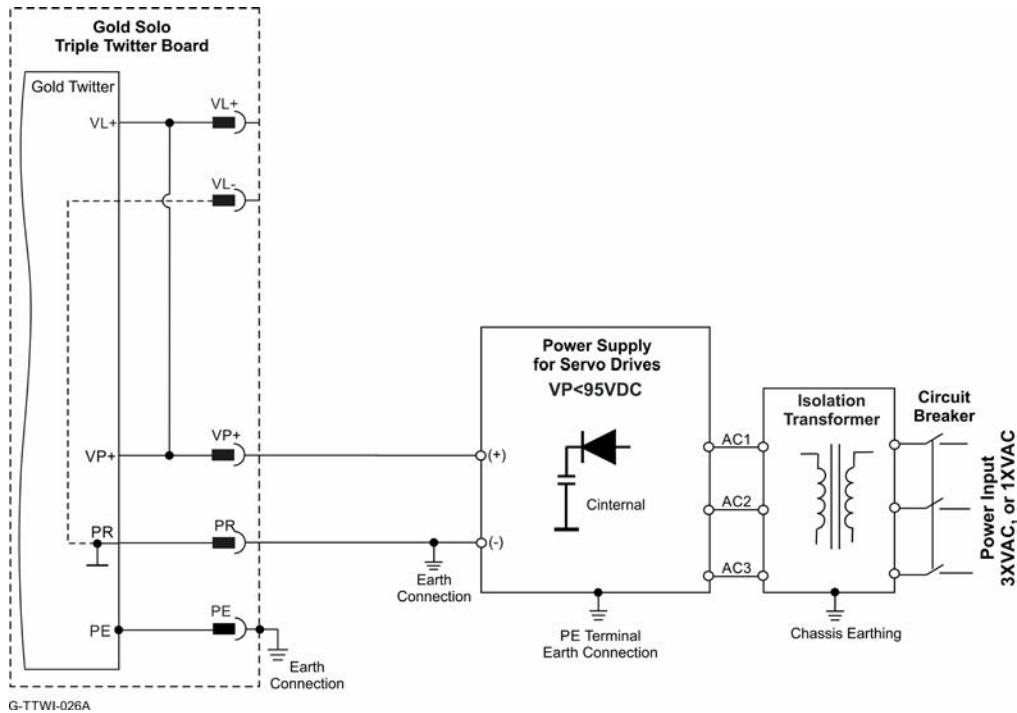

Figure 13: Single Power Supply (VP+ <95V) Connection Diagram



Note:

This option is available for 80VDC and 100VDC models only.



8.2. Drive Status Indicator

Figure 14 shows the position of the D1 red/green dual LED, which is used for immediate indication of the Initiation and Working states. For details refer to Chapter 7 Drive Status Indicator, in the MAN-G-Panel Mounted Drives Hardware manual.

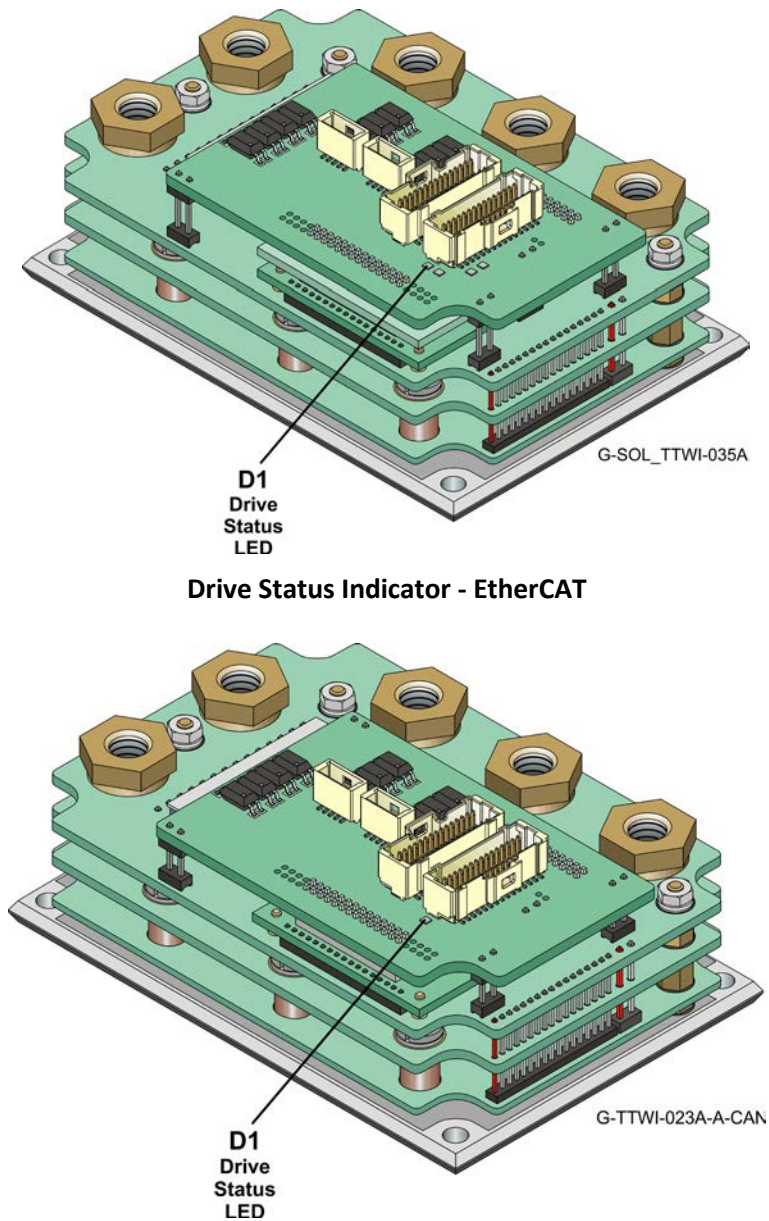

Figure 14: Drive Status Indicator - CAN

The red/green dual LED is used for immediate indication of the following states:

- **Initiation state:** In this state the LED indicates whether the drive is in the boot state (blinking red) or in the operational state (steady red).
- **Working state:** In this state the LED indicates whether the drive is in an amplifier failure state (red) or is ready to enable the motor (green).



8.3.J10 VL and Feedback Connector

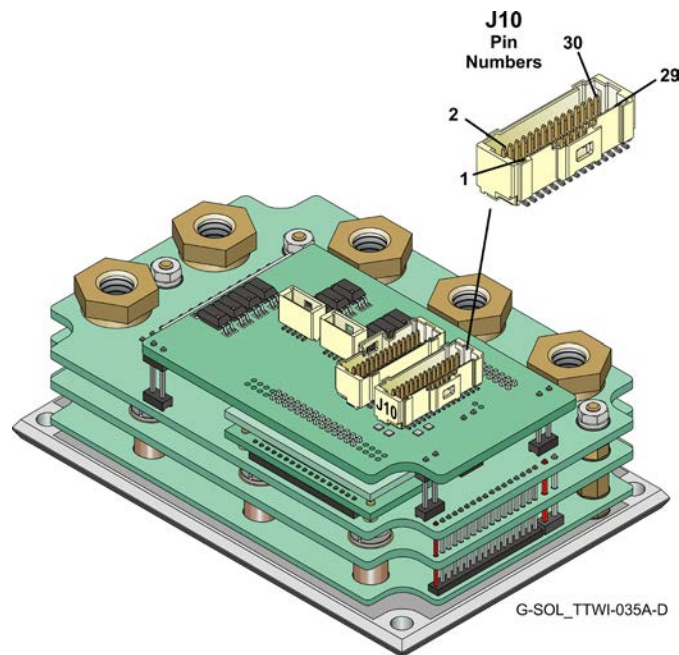

J10 VL & Feedback Connector

Feedback A/B/C, Digital Halls – see Section 9.2 in the manual: MAN-G-Board Level Modules Hardware Manual.

The following table describes the J10 VL and Feedback connections to the 2 x 15 pins female connector.

Pin J10	Signal	Function
1	PortA_ENC_A+ / ABS_CLK+	Channel A+ / Abs encoder clock +
2	PortB_ENC_A-	Port B Channel A-
3	PortA_ENC_A- / ABS_CLK-	Channel A- / Abs encoder clock -
4	PortB_ENC_A+	Port B Channel A+
5	PortA_ENC_B+ / ABS_DATA+	Channel B+ / Abs encoder data +
6	PortB_ENC_B-	Port B Channel B-
7	PortA_ENC_B- / ABS_DATA-	Channel B- / Abs encoder data -
8	PortB_ENC_B+	Port B Channel B+
9	PortA_ENC_INDEX+	Index+
10	PortB_ENC_INDEX-	Port B Index-
11	PortA_ENC_INDEX-	Index-
12	PortB_ENC_INDEX+	Port B Index+



Pin J10	Signal	Function
13	HA	Hall sensor A
14	PortC_ENCO_A-	Buffered Channel A- output / Pulse- / PWM-
15	HB	Hall sensor B
16	PortC_ENCO_A+	Buffered Channel A+ output/Pulse+/PWM+
17	HC	Hall sensor C
18	PortC_ENCO_B-	Buffered Channel B- output / Dir-
19	+5V	Encoder +5V supply with a total allowable maximum consumption of 200mA using Pins 19 or 26.
20	PortC_ENCO_B+	Buffered Channel B+ output / Dir+
21	COMRET	Common return
22	PortC_ENCO_Index-	Buffered Channel INDEX- output
23	COMRET	Common return
24	PortC_ENCO_Index+	Buffered Channel INDEX+ output
25	COMRET	Common return
26	+5V	Encoder +5V supply with a total allowable maximum consumption of 200mA using Pins 19 or 26.
27	COMRET	Common return
28	COMRET	Common return
29	VL-	Control 24V supply return
30	VL+	Control 24V supply

Table 5: Connector J10 – VL & Feedback

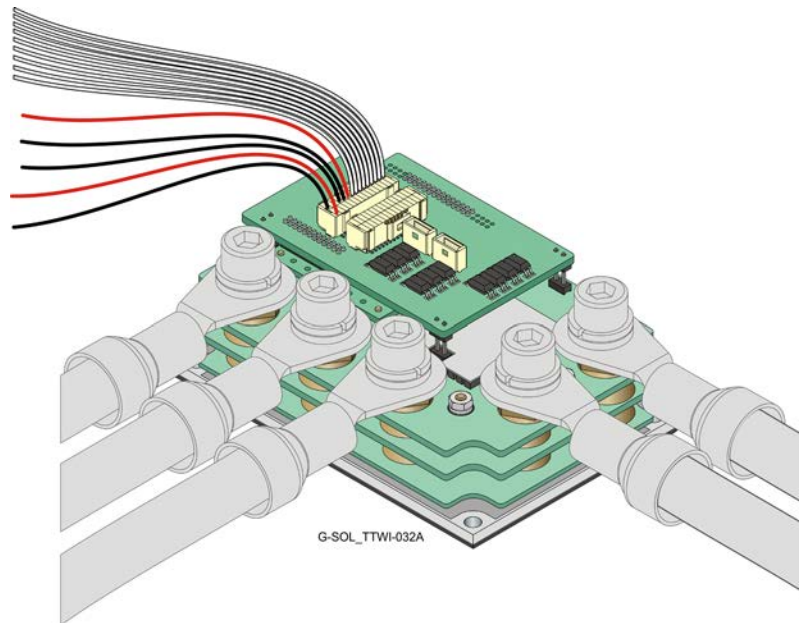

Figure 15: Connecting the Feedback Wires

For short distances between the drive and control, 0.5 to 1.0 m wires can be used and shielding is not required. For longer distances than 1.0 m and/or high EMI environment, shielded and twisted wires should be used. Drain wires should be connected to Elmo COMRET.



8.3.1. Port A

Refer to section 10.3 in the MAN-G-Board Level Modules Hardware Manual for further details of the Port A connections.

8.3.1.1. Incremental Encoder

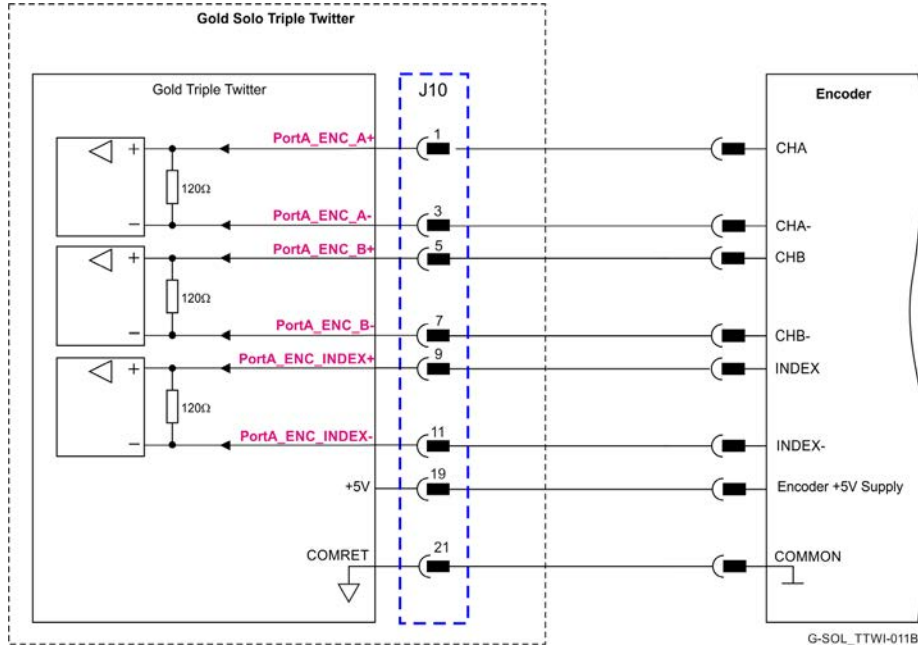

Figure 16: Port A Incremental Encoder Input – Recommended Connection Diagram

For short distances between the drive and control, 0.5 to 1.0 m wires can be used and shielding is not required. For longer distances than 1.0 m and/or high EMI environment, shielded and twisted wires should be used. Drain wires should be connected to Elmo COMRET.



8.3.1.2. Absolute Serial Encoder

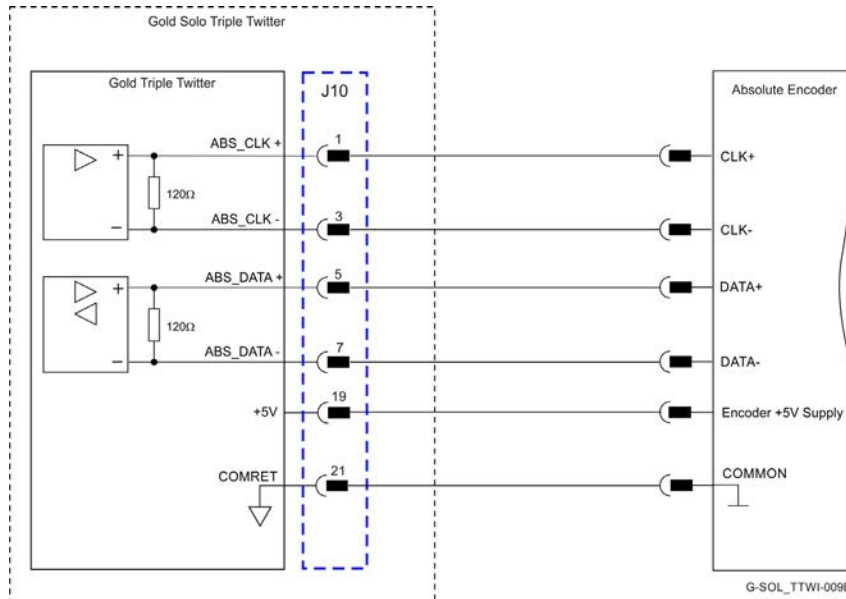

Figure 17: Absolute Serial Encoder – Recommended Connection Diagram for Sensors Supporting Data/Clock (e.g., Biss / SSI / EnDAT, etc.)

For short distances between the drive and control, 0.5 to 1.0 m wires can be used and shielding is not required. For longer distances than 1.0 m and/or high EMI environment, shielded and twisted wires should be used. Drain wires should be connected to Elmo COMRET.

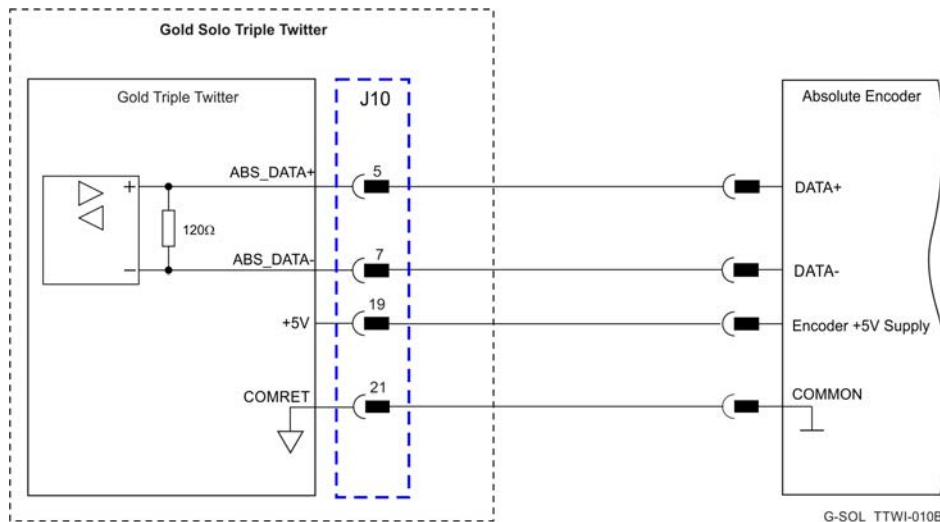

Figure 18: Absolute Serial Encoder – Recommended Connection Diagram for Sensors Supporting Data Line Only (NRZ types, e.g., Panasonic / Mitutoyo / etc.)

For short distances between the drive and control, 0.5 to 1.0 m wires can be used and shielding is not required. For longer distances than 1.0 m and/or high EMI environment, shielded and twisted wires should be used. Drain wires should be connected to Elmo COMRET.



8.3.1.3. Hiperface

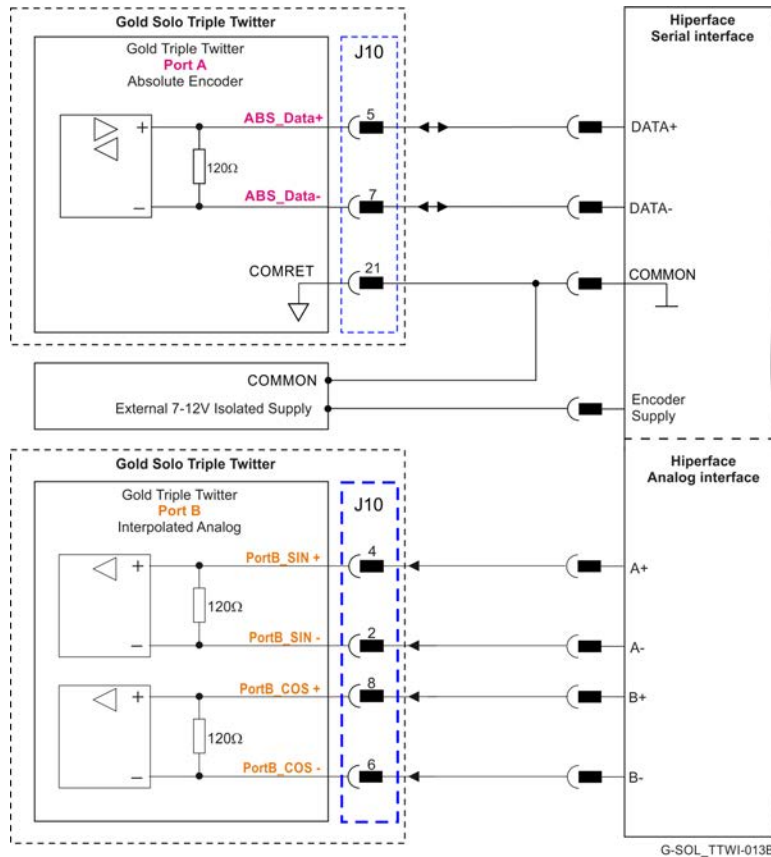

Figure 19: Absolute Serial Encoder – Recommended Connection Diagram for Stegmann Hiperface



Note:

When the Hiperface protocol is used, the RS-232 connection is not available.

For short distances between the drive and control, 0.5 to 1.0 m wires can be used and shielding is not required. For longer distances than 1.0 m and/or high EMI environment, shielded and twisted wires should be used. Drain wires should be connected to Elmo COMRET.

8.3.1.4. Hall Sensors

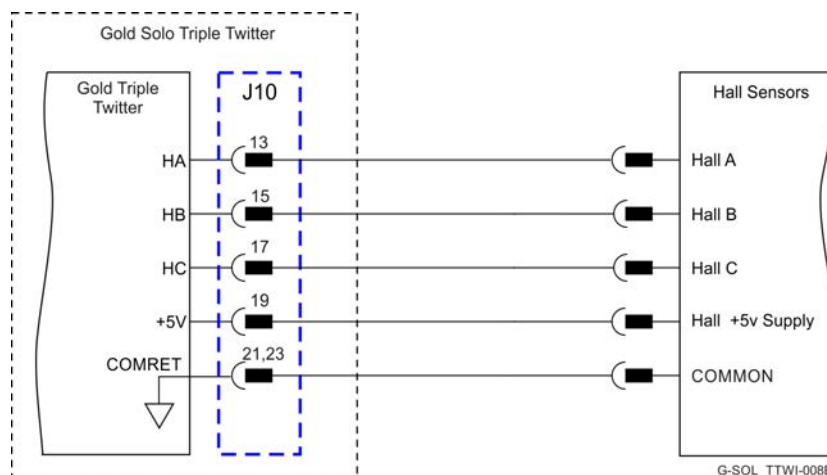

Figure 20: Hall Sensors Connection Diagram

For short distances between the drive and control, 0.5 to 1.0 m wires can be used and shielding is not required. For longer distances than 1.0 m and/or high EMI environment, shielded and twisted wires should be used. Drain wires should be connected to Elmo COMRET.



8.3.2. Port B

Refer to section 10.4 in the MAN-G-Board Level Modules Hardware Manual for further details of the Port B connections.

8.3.2.1. Incremental Encoder

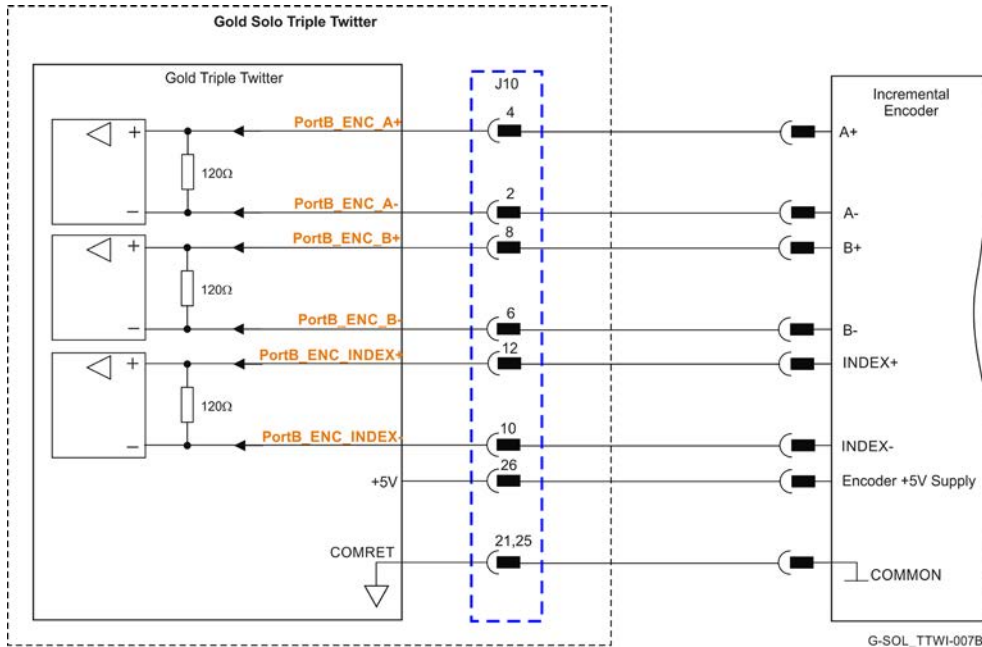

Figure 21: Port B Incremental Encoder Input – Recommended Connection Diagram

For short distances between the drive and control, 0.5 to 1.0 m wires can be used and shielding is not required. For longer distances than 1.0 m and/or high EMI environment, shielded and twisted wires should be used. Drain wires should be connected to Elmo COMRET.

8.3.2.2. Interpolated Analog Encoder

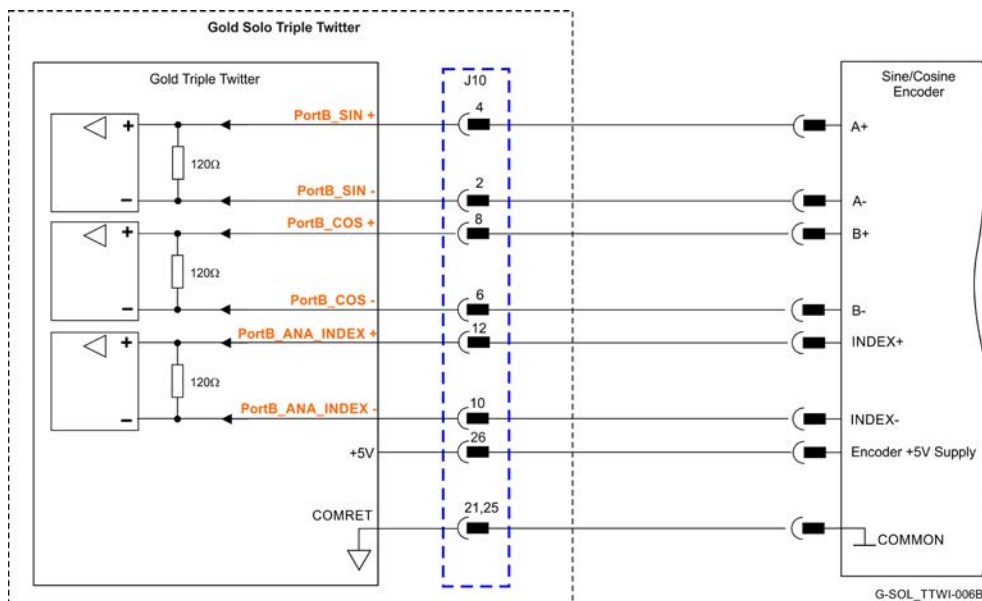

Figure 22: Port B - Interpolated Analog Encoder Connection Diagram

For short distances between the drive and control, 0.5 to 1.0 m wires can be used and shielding is not required. For longer distances than 1.0 m and/or high EMI environment, shielded and twisted wires should be used. Drain wires should be connected to Elmo COMRET.



8.3.2.3. Resolver

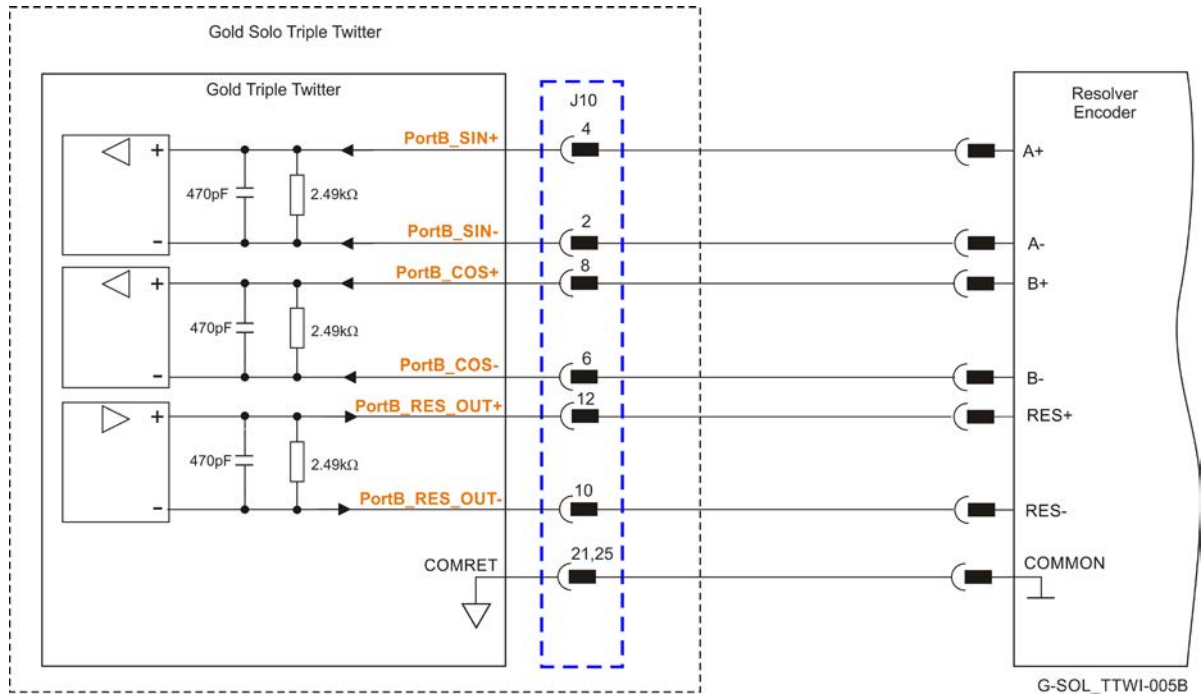

Figure 23: Port B – Resolver Connection Diagram

For short distances between the drive and control, 0.5 to 1.0 m wires can be used and shielding is not required. For longer distances than 1.0 m and/or high EMI environment, shielded and twisted wires should be used. Drain wires should be connected to Elmo COMRET.

8.3.3. Port C – Emulated Encoder Output (J10)

See Section 10.5 in the manual: MAN-G-Board Level Modules Hardware Manual for further details of Port C.

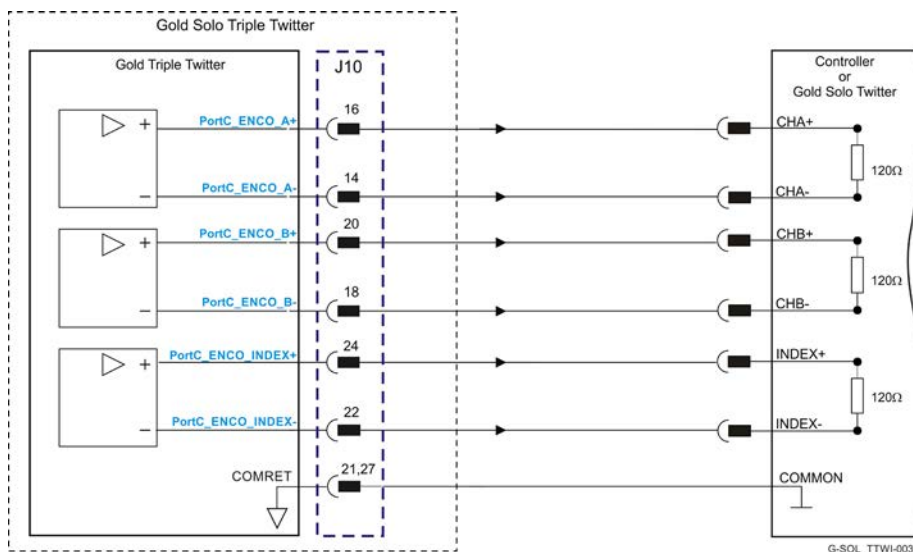
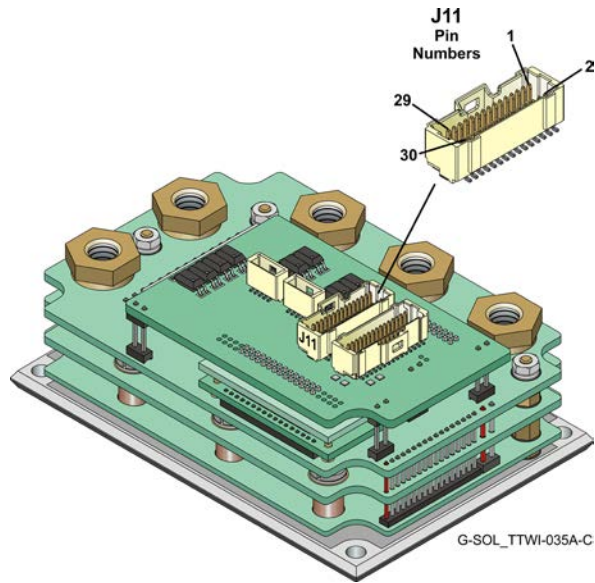

Figure 24: Emulated Encoder Differential Output – Recommended Connection Diagram

For short distances between the drive and control, 0.5 to 1.0 m wires can be used and shielding is not required. For longer distances than 1.0 m and/or high EMI environment, shielded and twisted wires should be used. Drain wires should be connected to Elmo COMRET.



8.4.J11 I/O and Communication Connector



J11 I/O and Communication Connector

Pin J11	Signal	Function
1	IN1	High speed programmable digital input 1 (opto isolated from control COMRET)
2	IN2	High speed programmable digital input 2 (opto isolated from control COMRET)
3	IN3	High speed programmable digital input 3 (opto isolated from control COMRET)
4	IN4	High speed programmable digital input 4 (opto isolated from control COMRET)
5	IN5	High speed programmable digital input 5 (opto isolated from control COMRET)
6	IN6	High speed programmable digital input 6 (opto isolated from control COMRET)
7	INRET	D _{in} return
8	INRET	D _{in} return
9	OUT1	Programmable output 1 (opto isolated from control COMRET)
10	OUT2	Programmable output 2 (opto isolated from control COMRET)
11	OUT3	Programmable output 3 (opto isolated from control COMRET)
12	OUT4	Programmable output 4 (opto isolated from control COMRET)



Pin J11	Signal	Function
13	OUTRET	D _{out} return
14	OUTRET	D _{out} return
15	STO1	STO 1 input opto isolated from control COMRET
16	STO2	STO 2 input opto isolated from control COMRET
17	STO_RET	STO signal return. The two digital STO inputs are optically isolated from the other parts of the drive, and share one return line.
18	STO_RET	STO signal return. The two digital STO inputs are optically isolated from the other parts of the drive, and share one return line.
19	COMRET	Common return
20	GPIO5 ANALOG IN	GPIO5 Analog input
21	ANALOG1+	Analog input 1
22	ANALOG1-	Analog input 1 complement
23	COMRET	Common return
24	COMRET	Common return
25	RS-232_TX	RS-232 Transmit
26	RS-232_RX	RS-232 Receive
27	USB_VBUS	USB VBUS detector (Only for EtherCAT version)
28	COMRET	Common return
29	USB D+	USB _P line (Only for EtherCAT version)
30	USB D-	USB _N line (Only for EtherCAT version)

Table 6: I/O, STO, Analog, RS-232, and USB Connector

STO (safety): For full details on STO, see Chapter 9 in the in the MAN-G-Board Level Modules Hardware manual for full details.

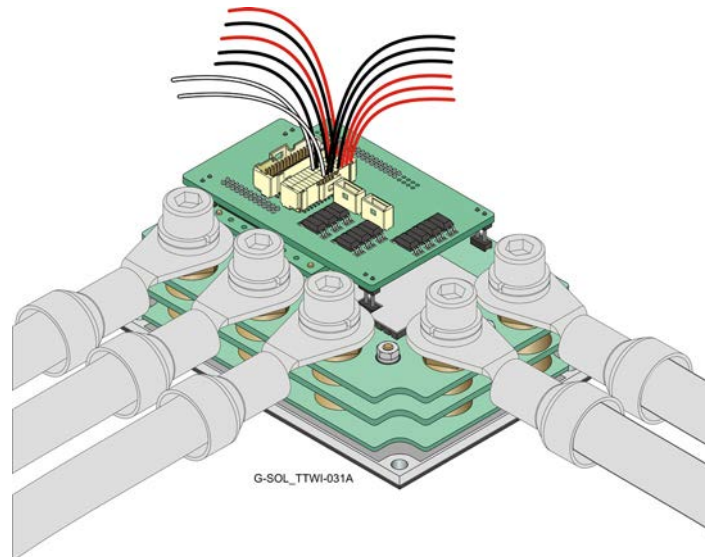

Figure 25: Connecting the USB, RS232, and Analog Input Wires

For USB, RS232, and Analog Input Wires

For short distances between the drive and control, 0.5 to 1.0 m wires can be used and shielding is not required. For longer distances than 1.0 m and/or high EMI environment, shielded and twisted wires should be used. Drain wires should be connected to Elmo COMRET.

For Digital Inputs/Outputs, STO

Wires can be always used, no need for twisting, no need for shielding.



8.4.1. Digital Inputs

8.4.1.1. Source PLC Voltage Level Digital Input

Feature	Details
Standard	Isolated PLC source Conforming to IEC 61131-2
Input current	$I_{in} = (V_{in} - 7.4) / 4.99 \text{ Kohm}$ $I_{in} = 920 \text{ uA @ } V_{in} = 12 \text{ V}$ $I_{in} = 4.5 \text{ mA @ } V_{in} = 30 \text{ V}$
High-level input voltage	$12 \text{ V} < V_{in} < 30 \text{ V}$
Low-level input voltage	$0 \text{ V} < V_{in} < 7 \text{ V}$
Minimum pulse width	$> 250 \text{ } \mu\text{sec}$
Execution time (all inputs): the time from application of voltage on input until execution is complete	$0 < T < 250 \text{ } \mu\text{sec}$
High-speed inputs – 1–6 minimum pulse width, in high-speed mode	$T > 5 \text{ } \mu\text{sec}$ if the input functionality is set to latch/capture (index/strobe). <div style="border: 1px solid black; padding: 5px; margin-bottom: 5px;"> Note: Home mode is high-speed mode and can be used for fast capture and precise homing. </div> <div style="border: 1px solid black; padding: 5px;"> Note: Highest speed is achieved when turning on optocouplers. </div>
Capture with differential input Port A, Port B Index	$T > 0.1 \text{ } \mu\text{sec}$ if the differential input functionality is set to touch probe/capture (index/strobe).
<p style="text-align: center;">G-SOL_TTWI-051A</p>	

Figure 26: Digital Input PLC Source Schematic



The following are the connection diagram of Digital inputs:

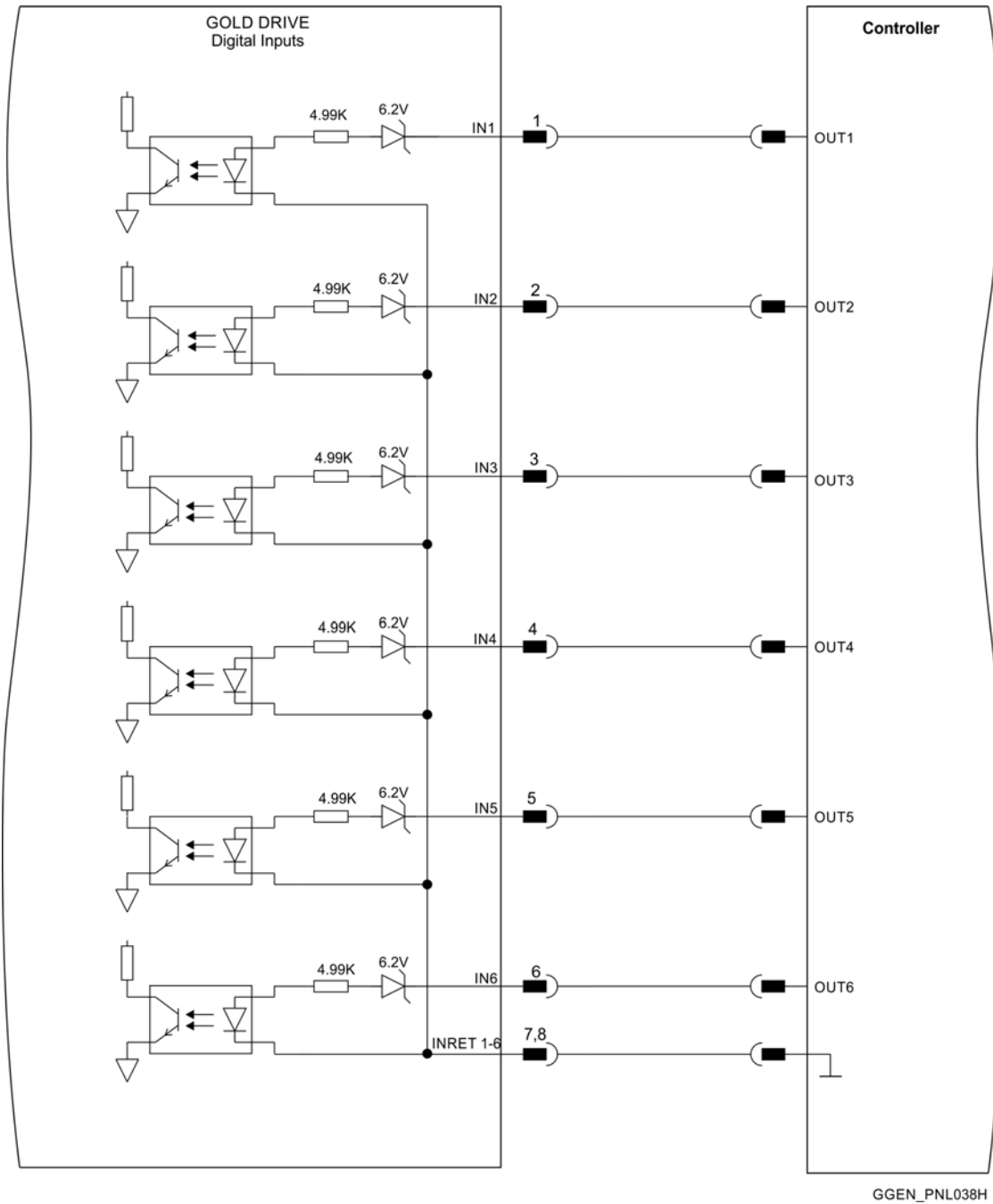

Figure 27: Digital Input Connection Diagram Example – Source PLC Option



8.4.1.2. Sink PLC Voltage Level Digital Input

Feature	Details
Type of input	Isolated PLC Sink
Input current	$I_{in} = (V_{in} - 7.4) / 4.99K\Omega$ $I_{in} = 920 \mu A @ V_{in} = 12 V$ $I_{in} = 4.5 mA @ V_{in} = 30 V$
High-level input voltage	$12 V < V_{in} < 30 V$
Low-level input voltage	$0 V < V_{in} < 7 V$
Minimum pulse width	$> 250 \mu sec$
Execution time (all inputs): the time from application of voltage on input until execution is complete	$0 < T < 250 \mu sec$
High-speed inputs – 1–6 minimum pulse width, in high-speed mode	$T > 5 \mu sec$ if the input functionality is set to latch/capture (index/strobe). <div style="border: 1px solid black; padding: 5px; margin-bottom: 5px;"> Note: Home mode is high-speed mode and can be used for fast capture and precise homing. </div> <div style="border: 1px solid black; padding: 5px;"> Note: Highest speed is achieved when turning on optocouplers. </div>
Capture with differential input Port A, Port B Index	$T > 0.1 \mu sec$ if the differential input functionality is set to touch probe/capture (index/strobe).
<p style="text-align: center;">Figure 28: Digital Input Sink PLC Schematic</p>	

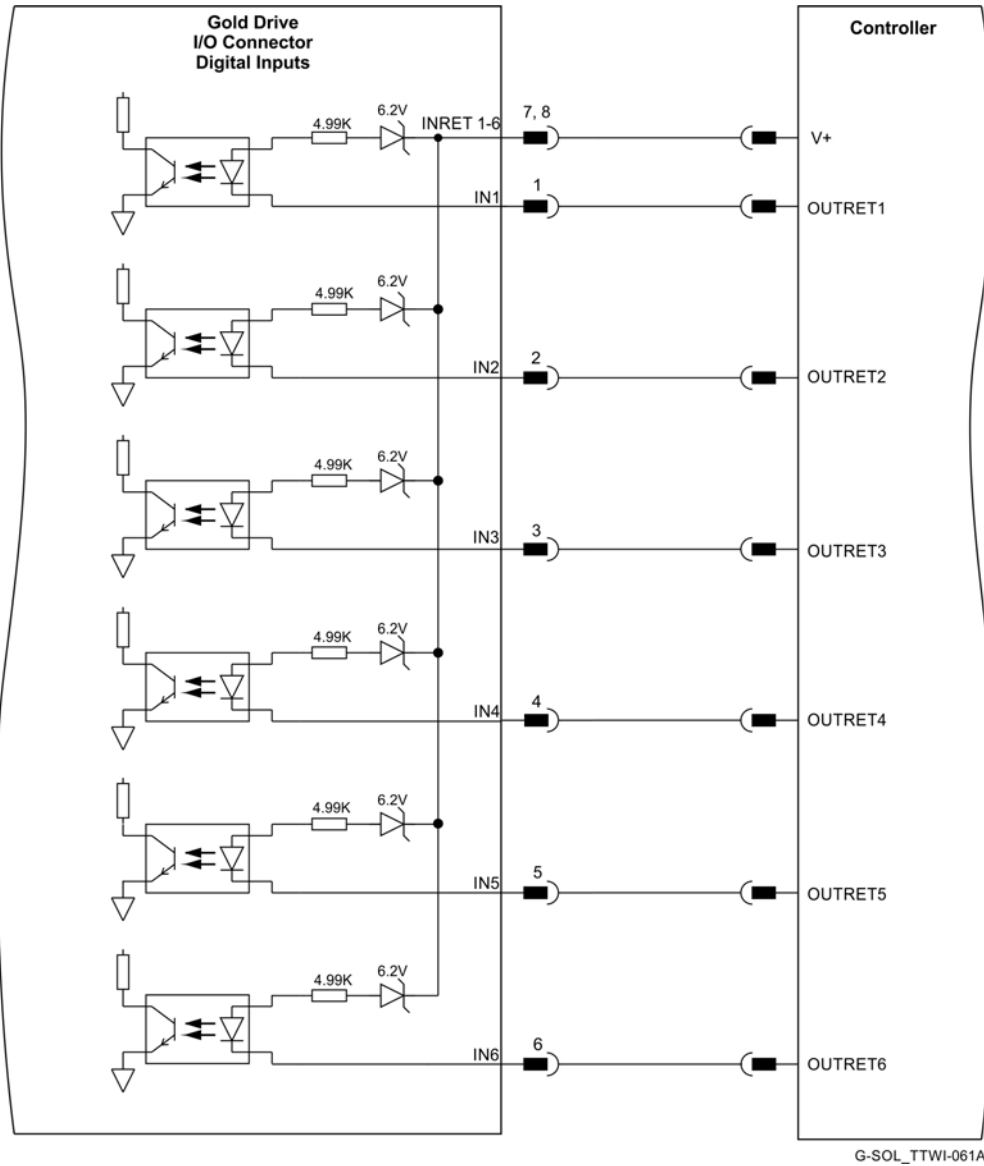

Figure 29: Digital Input Sink Mode Example – PLC voltage level Connection Diagram



8.4.1.3. Source 5V Logic Level Digital Input

Feature	Details
Type of input	Optically isolated
Input current for all inputs	$I_{in} = 3.8 \text{ mA @ } V_{in} = 5 \text{ V}$
High-level input voltage	$3.0 \text{ V} < V_{in} < 10 \text{ V}$, 5 V typical
Low-level input voltage	$0 \text{ V} < V_{in} < 0.8 \text{ V}$
Minimum pulse width	$> 250 \text{ } \mu\text{sec}$
Execution time (all inputs): the time from application of voltage on input until execution is complete	$0 < T < 250 \text{ } \mu\text{sec}$
High-speed inputs – 1–6 minimum pulse width, in high-speed mode	<p>$T > 5 \text{ } \mu\text{sec}$ if the input functionality is set to latch/capture (index/strobe).</p> <div style="border: 1px solid black; padding: 5px; margin-bottom: 5px;"> <p> Note: Home mode is high-speed mode and can be used for fast capture and precise homing.</p> </div> <div style="border: 1px solid black; padding: 5px;"> <p> Note: Highest speed is achieved when turning on optocouplers.</p> </div>

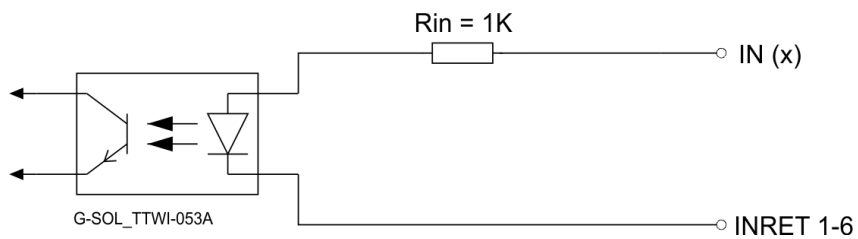

Figure 30: Digital Input 5V Logic Schematic

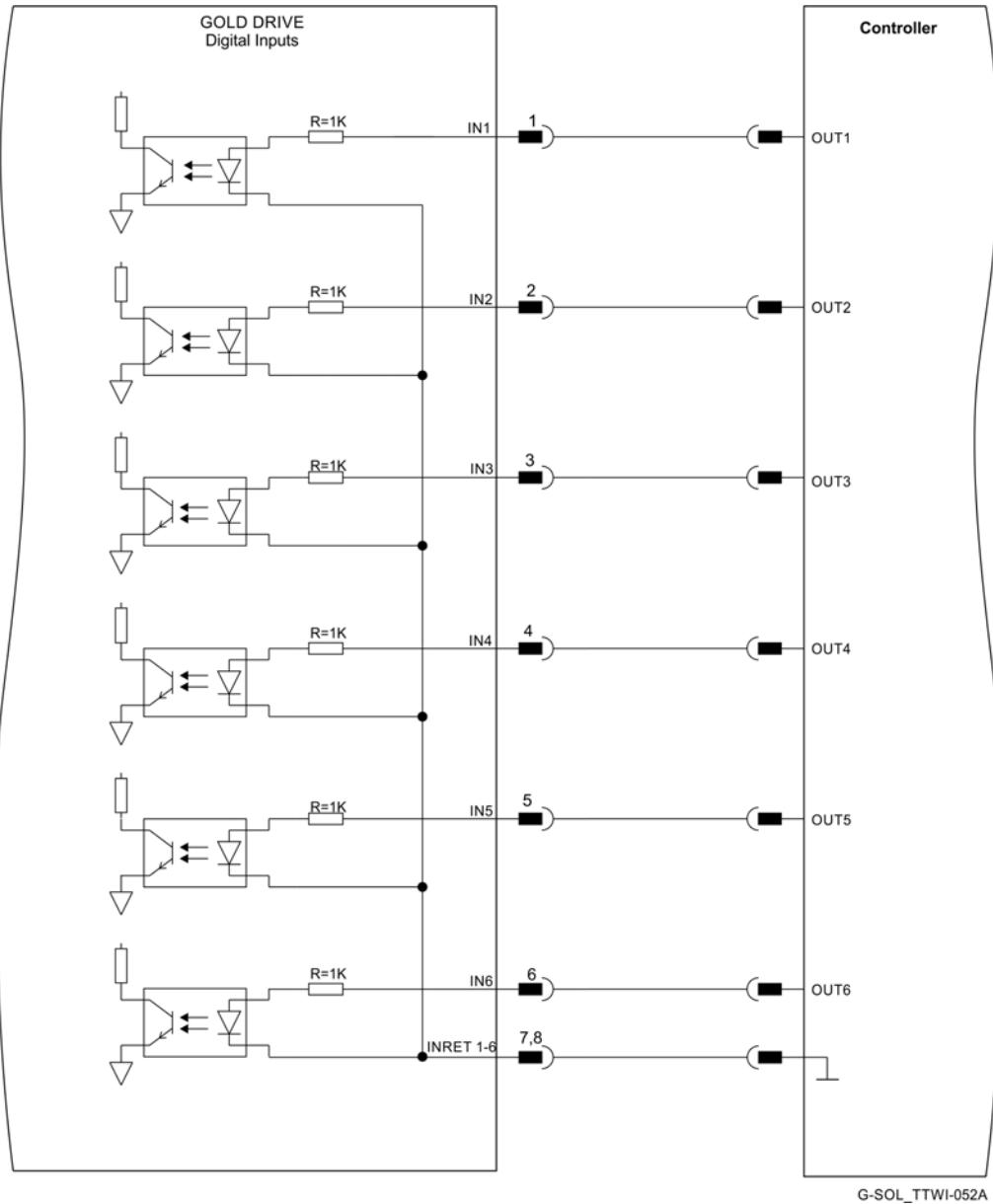

Figure 31: Digital Input Source 5V Logic Mode Connection Diagram



8.4.2. Digital Outputs

8.4.2.1. Source PLC Voltage Level Digital Output

Feature	Details
Type of output	Optically isolated PLC source
Supply output (VDD)	12 V to 30 V (typically 24 V)
Max. output current $I_{out} (max) (V_{out} = High)$	$I_{out} (max) \leq 30 \text{ mA}$
Collector Emitter saturation voltage	1 V
T_{on} (Time from low to high) If $V_{dd} = 24V$	< 15 μsec
T_{off} (Time from high to Low)	< 250 μsec
R_L	The external R_L must be selected to limit output current to no more than 30 mA. $R_L = \frac{VDD - 1}{I_{out} (max)}$
Executable time	$0 < T < 250 \mu\text{sec}$

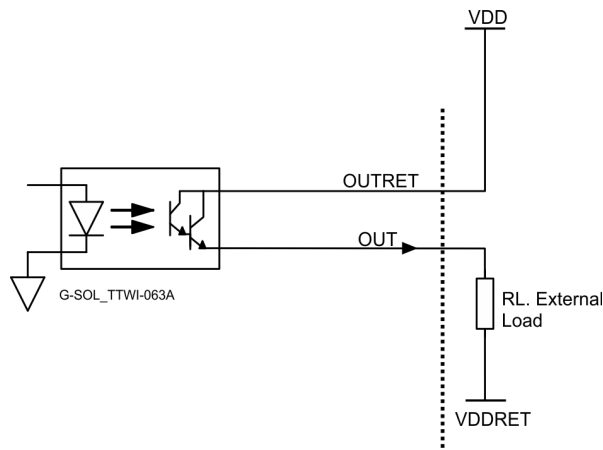
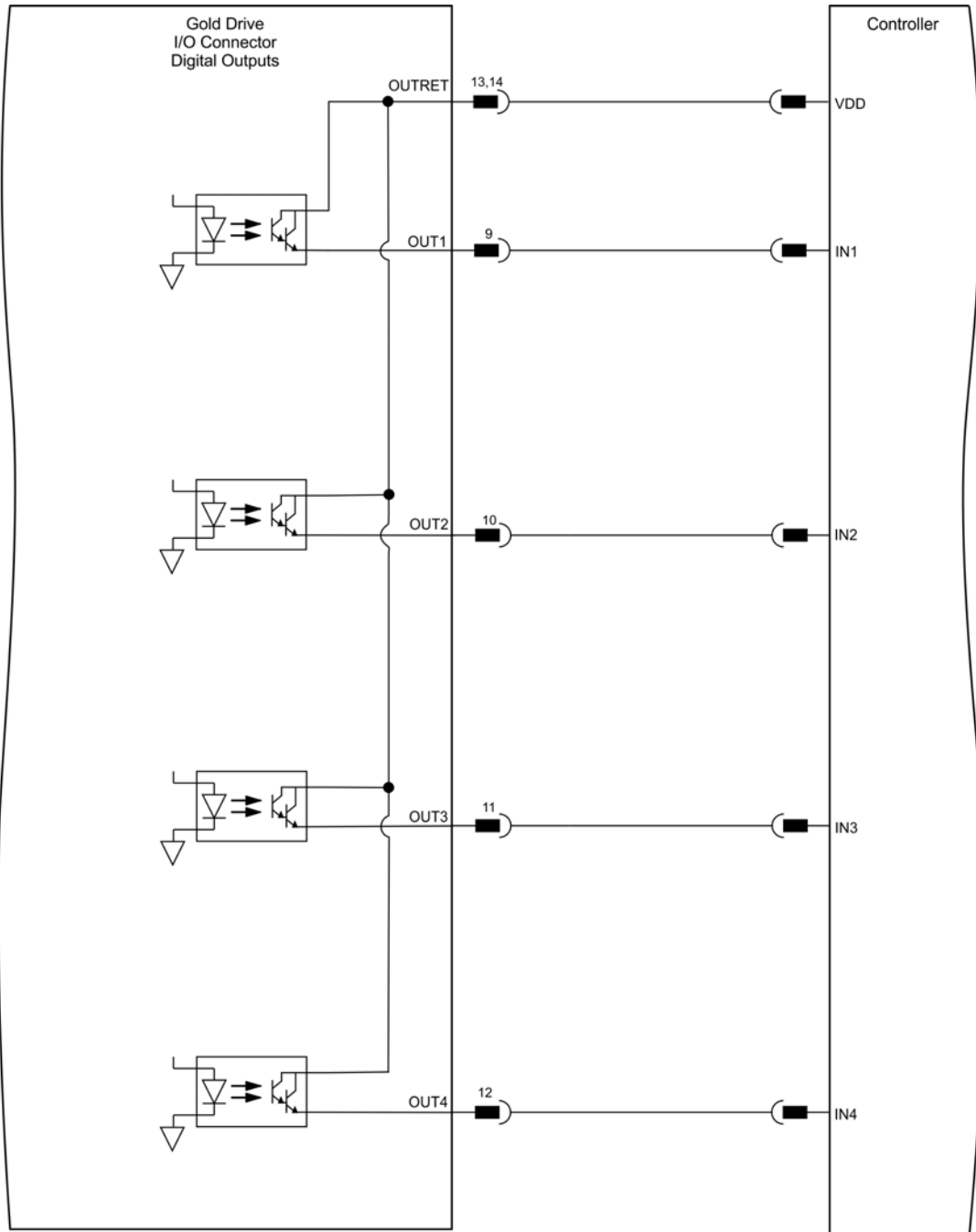

Figure 32: Digital Photodarlington Output Schematic – Source Mode PLC Level



G-SOL_TTWI-049A

Figure 33: Digital Output Connection Diagram Example – Source PLC Option

**8.4.2.2. Sink PLC Voltage Level Digital Output**

Feature	Details
Type of output	Optically isolated PLC Sink
Supply output (VDD)	12 V to 30 V (Typically 24 V)
Max. output current $I_{out} (max) (V_{out} = Low)$	$I_{out} (max) \leq 30 \text{ mA}$
Collector Emitter saturation voltage	1 V
T_{on} (Time from low to high) If $V_{dd} = 24V$	$< 15\mu\text{sec}$
T_{off} (Time from high to Low)	$< 300\mu\text{sec}$
R_L	The external R_L must be selected to limit output current to no more than 30 mA. $R_L = \frac{VDD - 1}{I_{out} (max)}$
Executable time	$0 < T < 250 \mu\text{sec}$
<p style="text-align: center;">Figure 34: Digital Photodarlington Output Schematic for Sink – PLC level</p>	

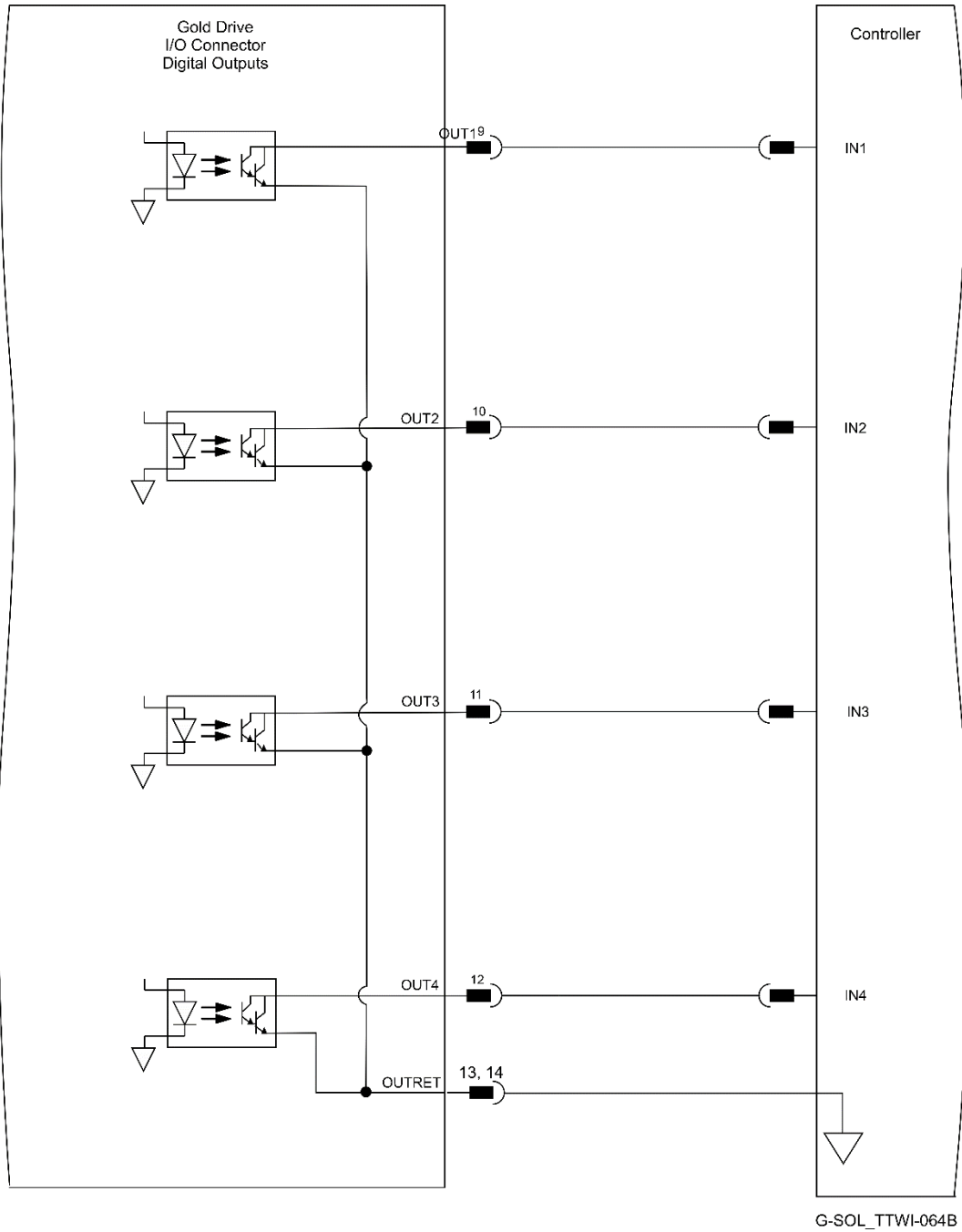

Figure 35: Digital Output Connection Diagram Example – Sink PLC Option

**8.4.2.3. Digital Outputs Source 5V Logic Mode**

Feature	Details
Type of output	Optically isolated 5V Logic source
Supply output (VDD)	< 30 V (Typically 5 V)
Max. output current $I_{out} (max) (V_{out} = High)$	$I_{out} (max) \leq 30 \text{ mA}$
Collector Emitter saturation voltage	1 V
T_{on} (Time from low to high) If $V_{dd} = 5V$	< 10 μ sec
T_{off} (Time from high to Low)	< 100 μ sec
R_L	The external R_L must be selected to limit output current to no more than 30 mA. $R_L = \frac{V_{DD} - 1}{I_{out} (max)}$
Executable time	$0 < T < 250 \mu\text{sec}$
<p>Figure 36: Digital Photodarlington Output Schematic – Source Mode 5V Logic Level</p>	

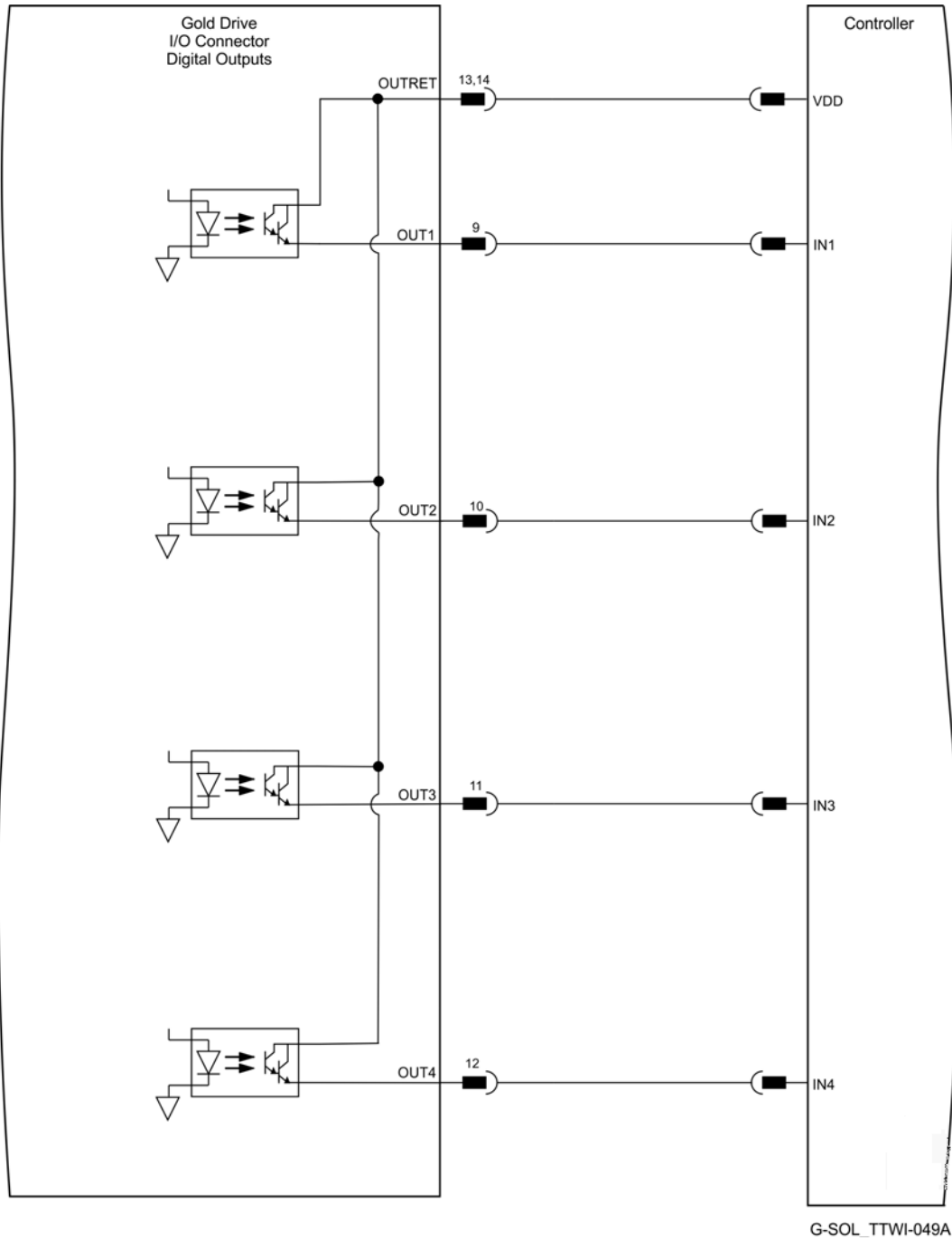

Figure 37: Digital Output Connection Diagram Example – Source 5V Logic Option



8.4.3. STO (Safe Torque Off)

For full details on STO, see Chapter 9 in the MAN-G-Board Level Modules Hardware manual.

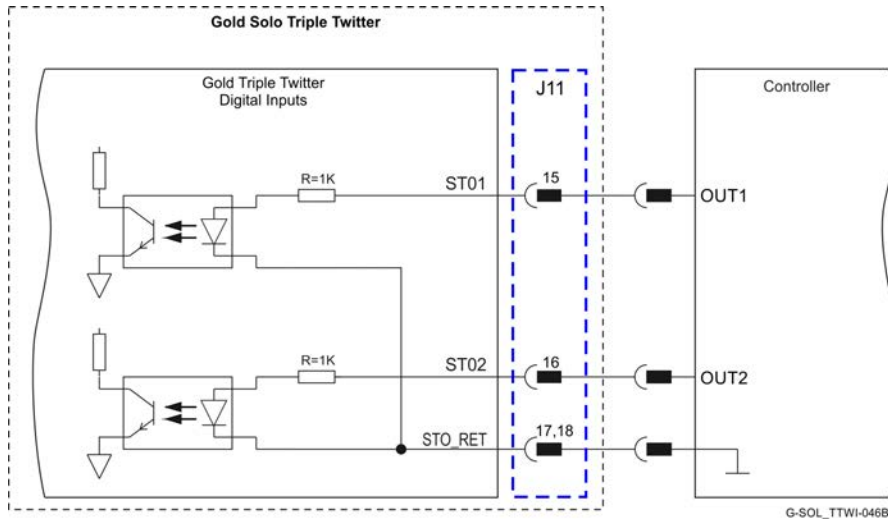

Figure 38: STO Input Connection – 5V Logic

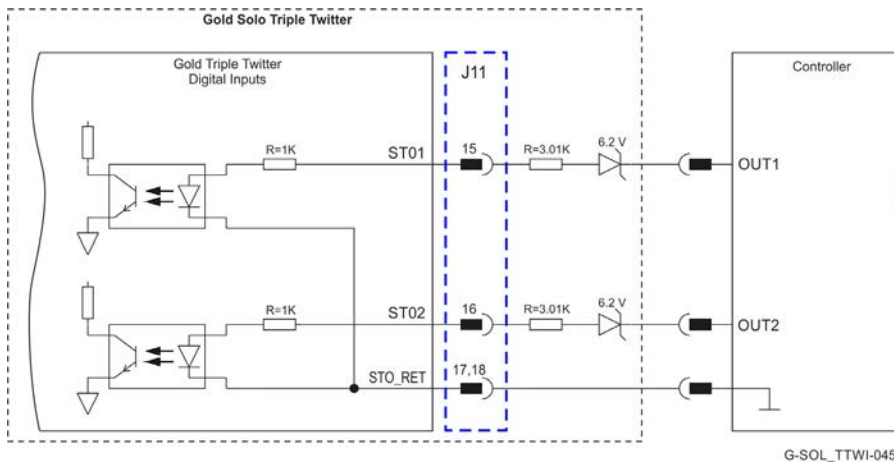

Figure 39: STO Input Connection – PLC (24V Logic)



8.4.4. Analog Input

For full details on Analog Inputs, see section 11.3 in the MAN-G-Board Level Modules Hardware manual.

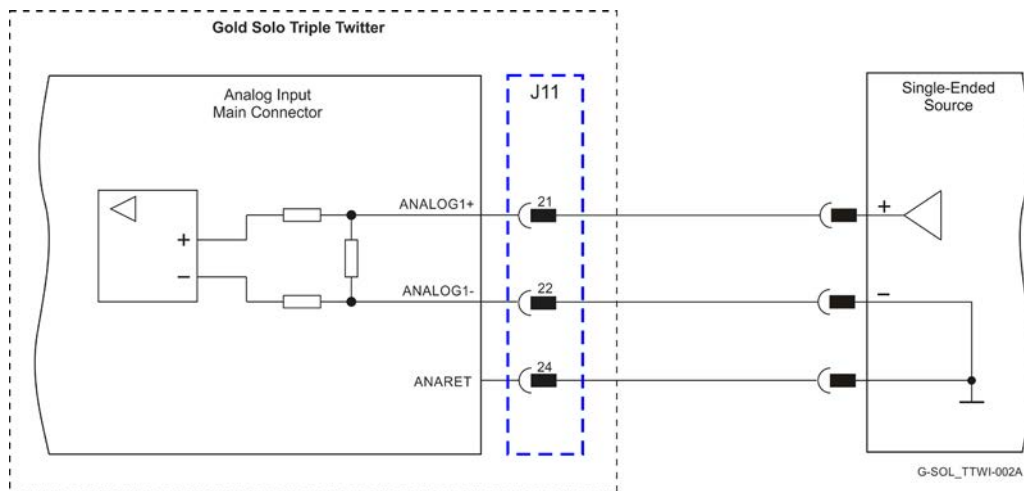

Figure 40: Analog Input

For short distances between the drive and control, 0.5 to 1.0 m wires can be used and shielding is not required. For longer distances than 1.0 m and/or high EMI environment, shielded and twisted wires should be used. Drain wires should be connected to Elmo COMRET.

8.4.5. Standard RS-232

Figure 41 describes the Standard RS-232 connection diagram.

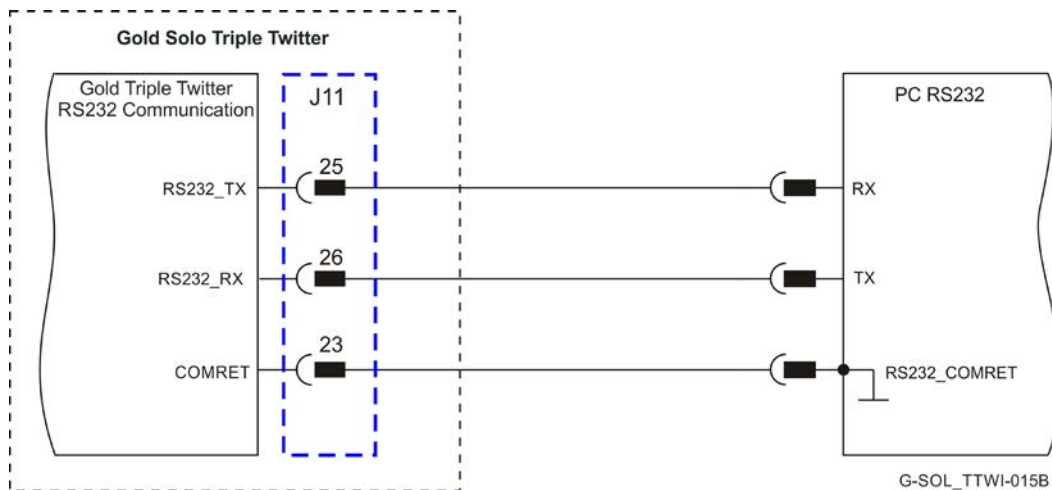

Figure 41: Standard RS-232 Connection Diagram

For short distances between the drive and control, 0.5 to 1.0 m wires can be used and shielding is not required. For longer distances than 1.0 m and/or high EMI environment, shielded and twisted wires should be used. Drain wires should be connected to Elmo COMRET.



8.4.6. USB 2.0 Communication (Only for EtherCAT version)

For full details on USB communication, see section 12.1 in the MAN-G-Board Level Modules Hardware manual.

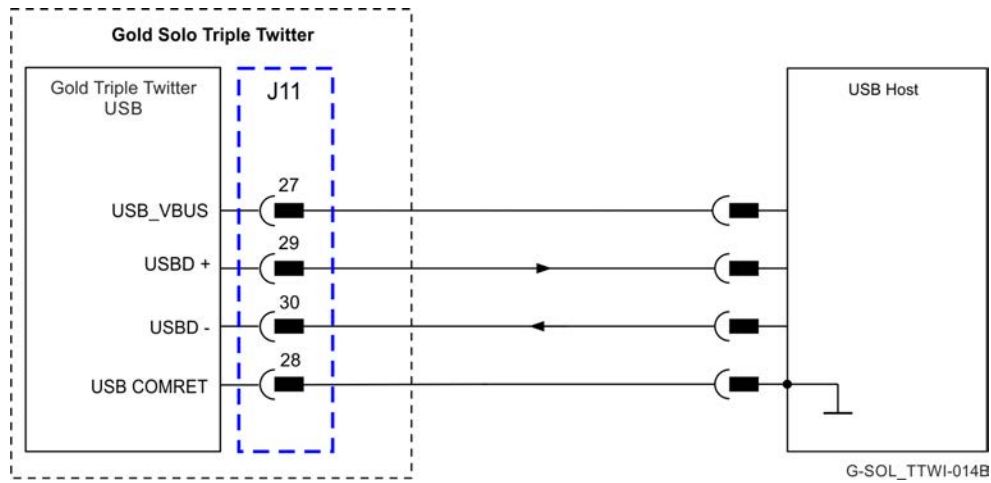

Figure 42: USB Network Diagram

For short distances between the drive and control, 0.5 to 1.0 m wires can be used and shielding is not required. For longer distances than 1.0 m and/or high EMI environment, shielded and twisted wires should be used. Drain wires should be connected to Elmo COMRET.



8.5. EtherCAT Communications Version

Fieldbus communications are industrial network protocols for real-time distributed control that allows connection of servo drives. The Gold Solo Triple Twitter supports the following EtherCAT fieldbus type industrial network protocol:

Fieldbus Type	Product Number
EtherCAT	G-SOLTTWITXXX/YYYEESV

8.5.1. EtherCAT IN/Ethernet Connector (J17)

Refer to section 12.2 in the MAN-G-Panel Mounted Drives Hardware manual for more details.

Pin (J17)	Signal	Function
1	EtherCAT_IN_TX+/Ethernet_TX+	EtherCAT in/Ethernet transmit +
2	EtherCAT_IN_TX-/Ethernet_TX-	EtherCAT in/Ethernet transmit -
3	EtherCAT_IN_RX+/Ethernet_RX+	EtherCAT in/Ethernet receive +
4	EtherCAT_IN_RX-/Ethernet_RX-	EtherCAT in/Ethernet receive -
5	COMRET	Shield drain wire

Pin Positions	Cable Connector
	<p>Ethernet Cable Connector</p>

Table 7: EtherCAT IN / Ethernet Pin Assignments



Note:
Always use CAT5e cables.



8.5.2. EtherCAT OUT Connector (J18)

See Section 12.2 in the MAN-G-Panel Mounted Drives Hardware manual for the electrical diagram.

Pin (J18)	Signal	Function
1	EtherCAT_OUT_TX+	EtherCAT out transmit +
2	EtherCAT_OUT_TX-	EtherCAT out transmit -
3	EtherCAT_OUT_RX+	EtherCAT out receive +
4	EtherCAT_OUT_RX-	EtherCAT out receive -
5	COMRET	Shield drain wire

Pin Positions	Cable Connector
	<p>Ethernet Cable Connector</p>

Table 8: EtherCAT OUT Pin Assignments



Note:

Always use CAT5e cables.



8.5.3. EtherCAT Option

For full details on EtherCAT communication, see Section 12.2 in the in the MAN-G-Board Level Modules Hardware manual.



Note:

The EtherCAT IN port can be configured to an Ethernet Port.

8.5.3.1. EtherCAT Communication

This section only describes the EtherCAT communication, and the pinout drawing of the connector.



Important:

When the EtherCAT is connected and the FoE is in operation, the USB cable connection must be disconnected.

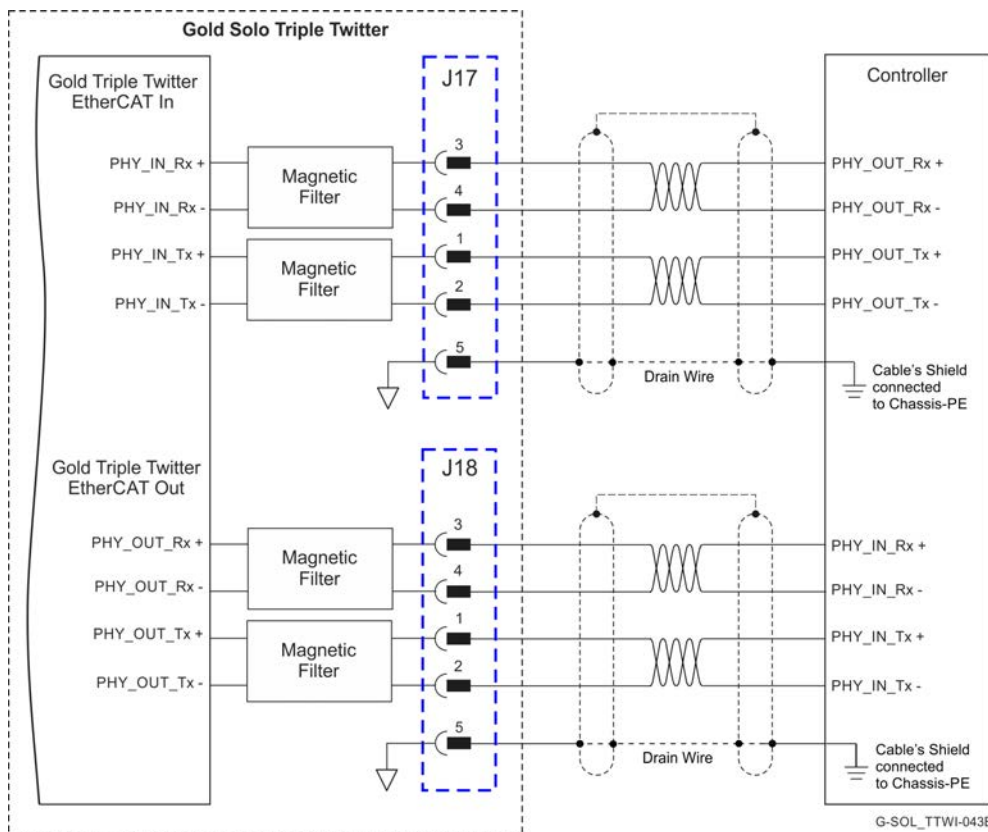

Figure 43: EtherCAT Connection Schematic Diagram



Note:

Always use CAT5e cables.



8.5.3.2. EtherCAT Status Indicator (D2)

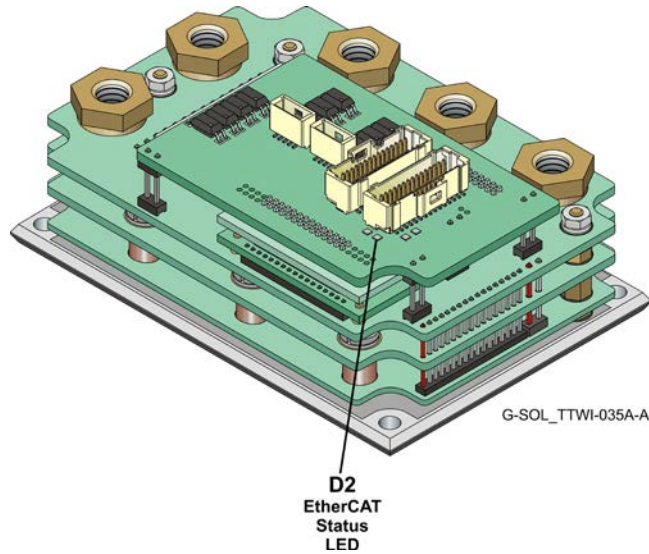

Figure 44: EtherCAT Status LED

The EtherCAT status indicator D2 is a single red/green dual bi-colored LED that combines the green RUN indicator and the red ERROR indicator of the EtherCAT state machine. For further details, see the EtherCAT Application Manual.

8.5.3.3. EtherCAT Link Indicators (D3, D4)

The Gold Solo Triple Twitter can serve as an EtherCAT slave device. For this purpose it has two Ports J17 and J18, which are designated as EtherCAT In and EtherCAT Out. Each of these Ports has a status LED; D3 EtherCAT In and D4 EtherCAT Out, which are shown in Figure 45.

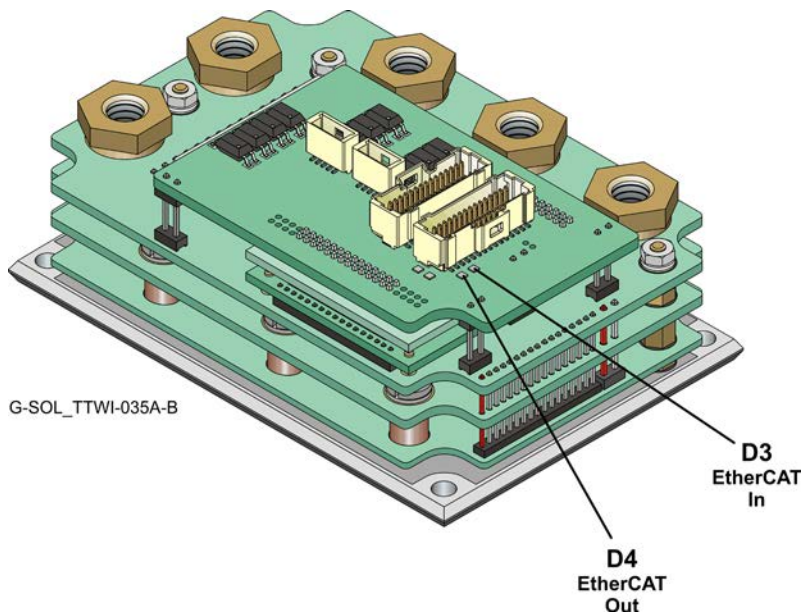

Figure 45: Ethernet Connector LEDs

The green LEDs D3 and D4 are the link/activity indicators. They show the state of the applicable physical link and the activity on that link; blinking green, D3 for the Link Act IN, and D4 for the Link Act OUT.



8.6. CAN Communications Version

Fieldbus communications are industrial network protocols for real-time distributed control that allows connection of servo drives. The Gold Solo Triple Twitter supports the following CAN fieldbus type industrial network protocol:

Fieldbus Type	Product Number
CAN	G-SOLTTWITXXX/YYSESV

See Section 12.4 in the MAN-G-Panel Mounted Drives Hardware manual for the electrical diagram.

8.6.1. CAN IN Connector (J17)

Pin (J17)	Signal	Function
1	NC	NC
4	CAN_L	CAN_L bus line (dominant low)
3	CAN_H	CAN_H bus line (dominant high)
2	CAN_RET	CAN Return
5	COMRET	Shield drain wire

Pin Positions	Cable Connector
	<p>CAN Cable Connector</p>

Table 9: CAN IN Connector Pin Assignments



Note:
Always use CAT5e cables.



8.6.2. CAN OUT Connector (J18)

Pin (J18)	Signal	Function
1	NC	NC
4	CAN_L	CAN_L bus line (dominant low)
3	CAN_H	CAN_H bus line (dominant high)
2	CAN_RET	CAN Return
5	COMRET	Shield drain wire

Pin Positions	Cable Connector
 <p>J18 Pin Numbers</p> <p>G-TTWI-023A-B-CAN</p>	 <p>CAN Cable Connector</p>

Table 10: CAN OUT Connectors Pin Assignments



Note:
Always use CAT5e cables.

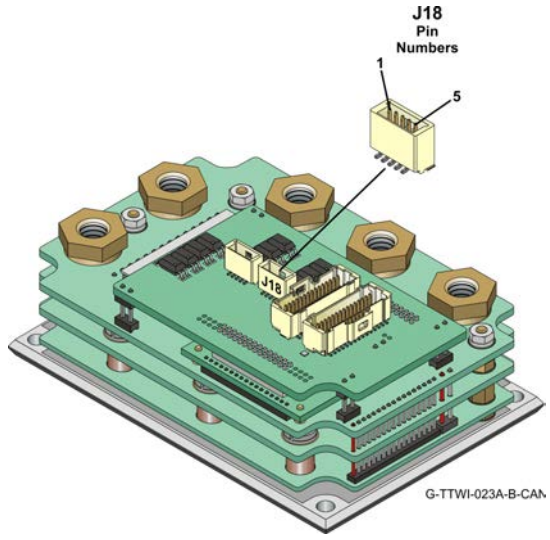
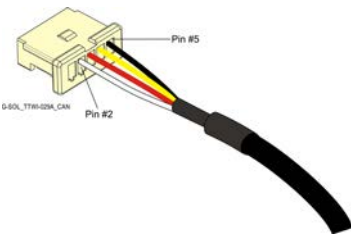

8.6.3. CAN Option

For full details on CANopen communication, see section 14.3 in the MAN-G-Board Level Modules Hardware manual.

8.6.3.1. Interface

The Gold Solo Triple Twitter includes the CAN transceiver, common mode choke, and a CAN Bus Protector against ESD and other harmful transient voltage events.

The following signals describe how to connect CAN to the external connector.

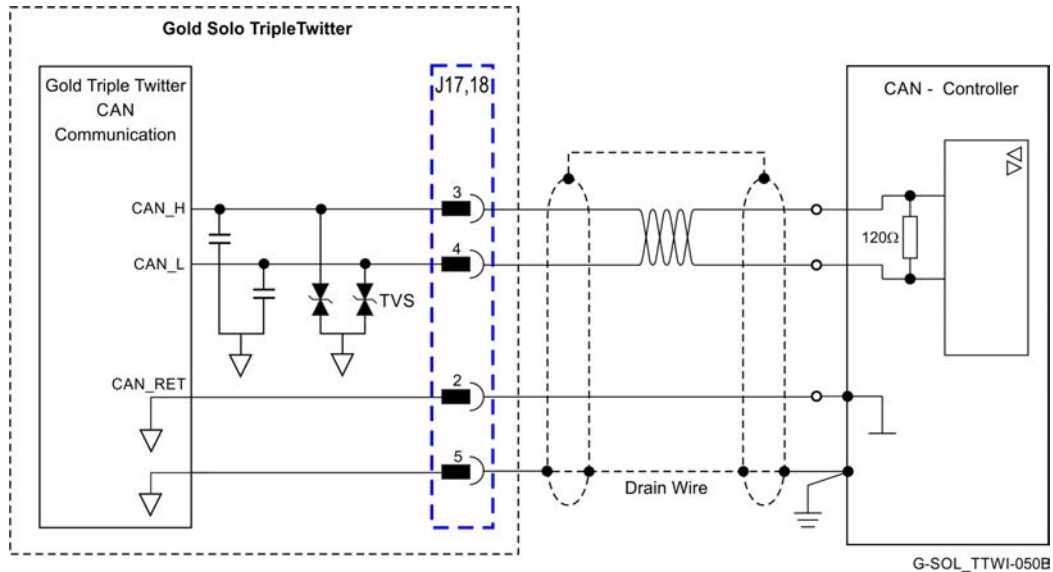

Figure 46: CAN Interface



8.6.3.2. CAN Layout

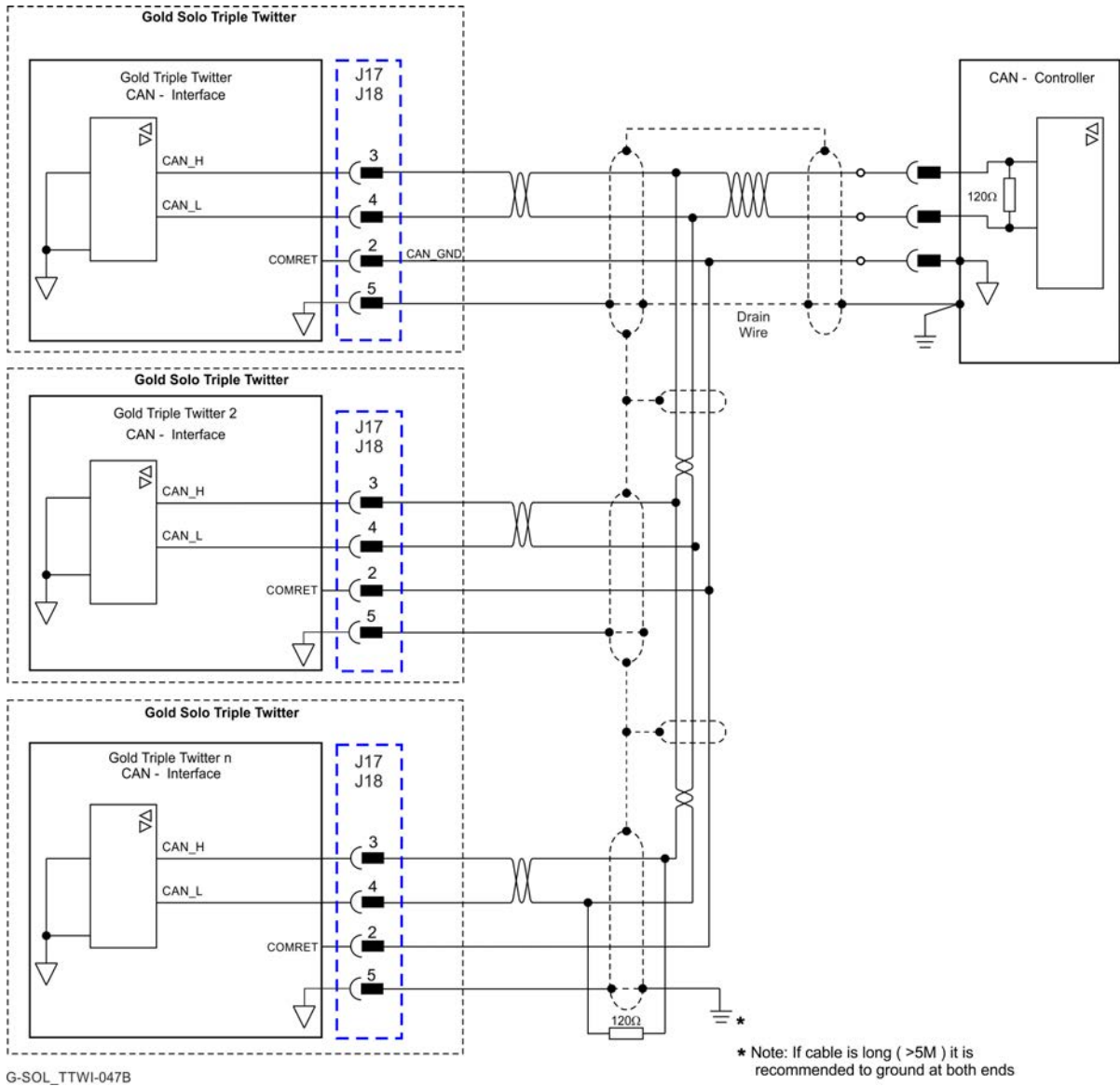

Figure 47: CAN Network Diagram – Drop Off Topology



Caution:

When installing CAN communication, ensure that each servo drive is allocated a unique ID. Otherwise, the CAN network may “hang”.



Note:

Daisy chain topology can also be accomplished using J18.



Note:

Always use CAT5e cables.



Chapter 9: Powering Up

After the Gold Solo Triple Twitter is connected to its device, it is ready to be powered up.



Caution:

Before applying power, ensure that the DC supply is within the specified range and that the proper plus-minus connections are in order.

9.1. Initializing the System

After the Gold Solo Triple Twitter has been connected and mounted, the system must be set up and initialized. This is accomplished using the *EASII*, Elmo's Windows-based software application. Install the application and then perform setup and initialization according to the directions in the *EASII User Manual*.

9.2. Heat Dissipation

The best way to dissipate heat from the Gold Solo Triple Twitter is to mount it so that its heat-sink is attached to the machine chassis. If mounted with its heat-sink suspended, then for best results mount the servo drive faced upwards and leave approximately 10 mm of space between the Gold Solo Triple Twitter's heat-sink and any other assembly.

9.2.1. Heat Dissipation Data

Graphic representations of heat dissipation are TBD.

9.2.2. How to Use the Chart

The heat dissipation charts are TBD.



Chapter 10: Dimensions

This chapter provides detailed technical dimensions regarding the Gold Solo Triple Twitter.

ECAT

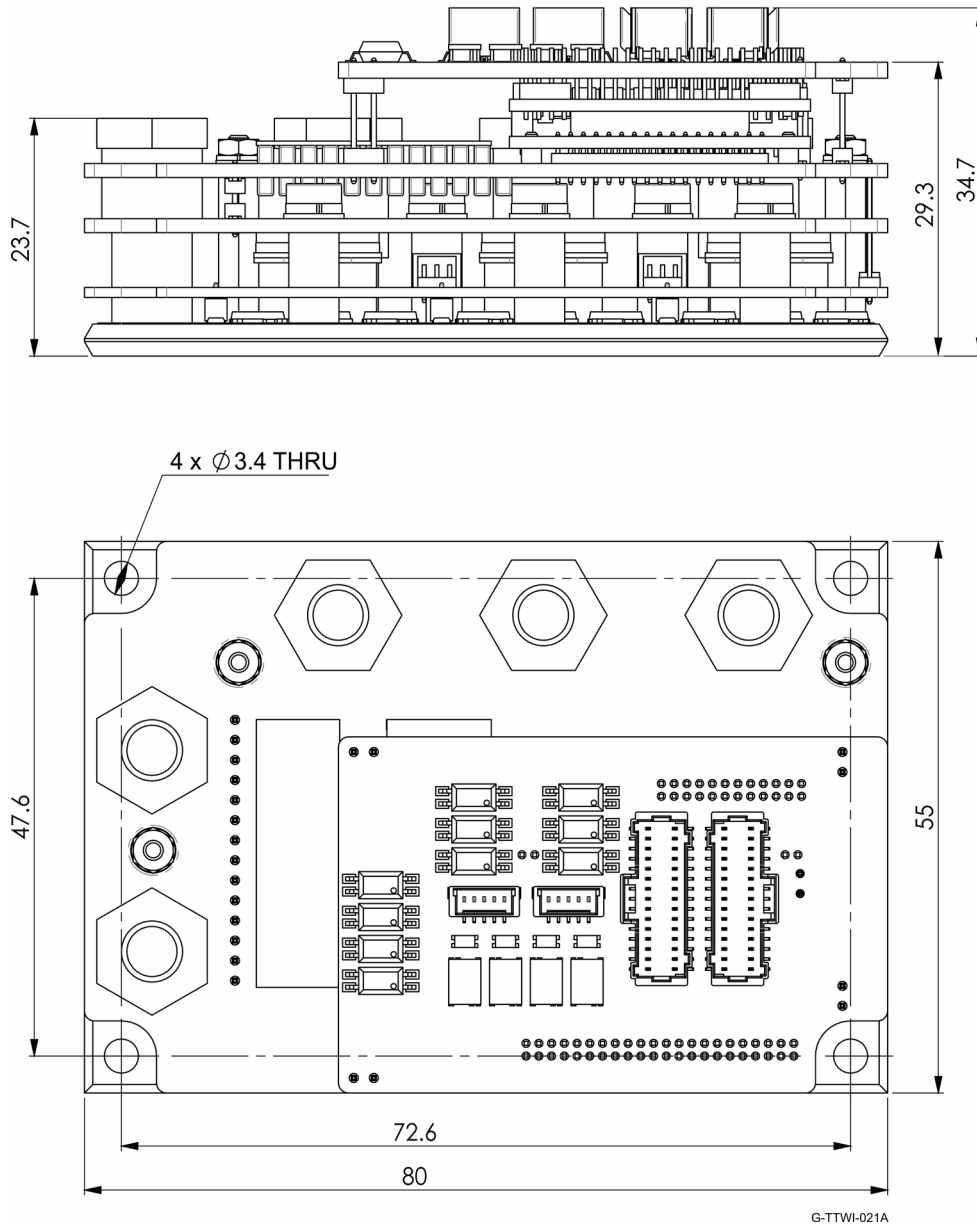

G-TTWI-021A

Figure 48: G-Solo Triple Twitter –EtherCAT version



CAN

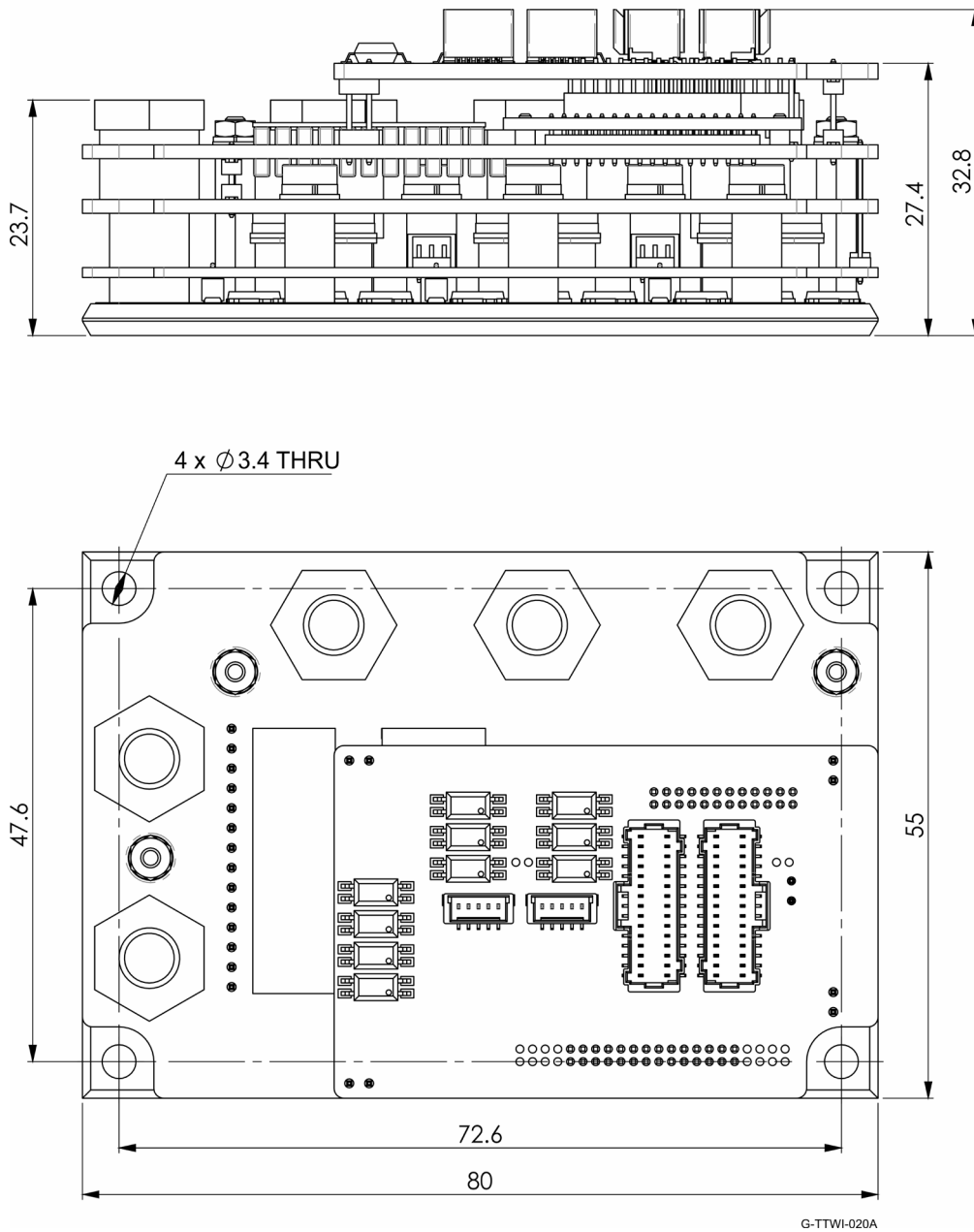

G-TTWI-020A

Figure 49: G-Solo Triple Twitter –CAN version



Chapter 11: Cables and Accessories

The following power cable kit can be purchased from Elmo for the Gold Solo Triple Twitter:

Part Number	Description (Gauge)
CBL-GSOLTWITPOWKIT03	Cable kit 4 AWG

The following describes the control kits available for the Gold Solo Triple Twitter.

Part Number	Description
CBL-GSOLTWIKIT03	Cable kit for EtherCAT model
CBL-GSOLTWIKIT04	Cable kit for CAN model
CBL-GSOLTWIKIT05	CONNECTORS AND PINS KIT

A specific Crimping Tool (available for purchase from Elmo) is required to mount extra connecting pins on the wires. A number of wires are provided in the kit as pre-crimped for convenience:



Crimping Tool
Molex P/N 63819-1500
Elmo P/N TOOL-P000040



Pins for Single Row Connector
MOLEX P/N 501334-0100
Pins for Dual Row Connector
MOLEX P/N 501193-3000

Inspiring Motion

Since 1988

For a list of Elmo's branches, and your local area office, refer to the Elmo site www.elmomc.com

