

**Inspiring Motion**

*Since 1988*

# **Gold Solo Double Twitter Digital Servo Drive Installation Guide CAN and EtherCAT**

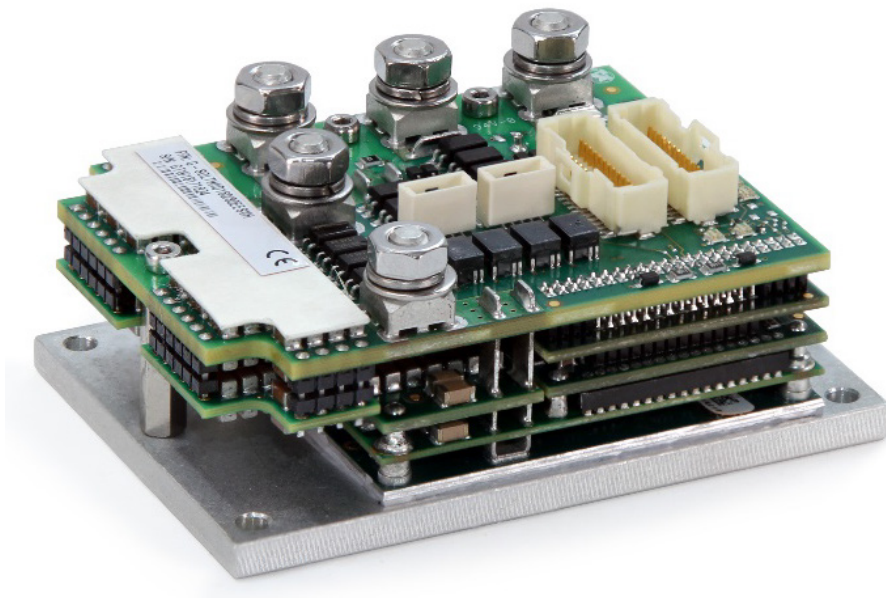

September 2021 (Ver. 1.008)

[www.elmomc.com](http://www.elmomc.com)

**Elmo**  
Motion Control

# Notice

This guide is delivered subject to the following conditions and restrictions:

- This guide contains proprietary information belonging to Elmo Motion Control Ltd. Such information is supplied solely for the purpose of assisting users of the Gold Solo Double Twitter servo drive in its installation.
- The text and graphics included in this manual are for the purpose of illustration and reference only. The specifications on which they are based are subject to change without notice.
- Information in this document is subject to change without notice.

Document no. MAN-G-SOLTWIB\_160 (Ver. 1.008)

Copyright © 2021

Elmo Motion Control Ltd.

All rights reserved.

## Catalog Number

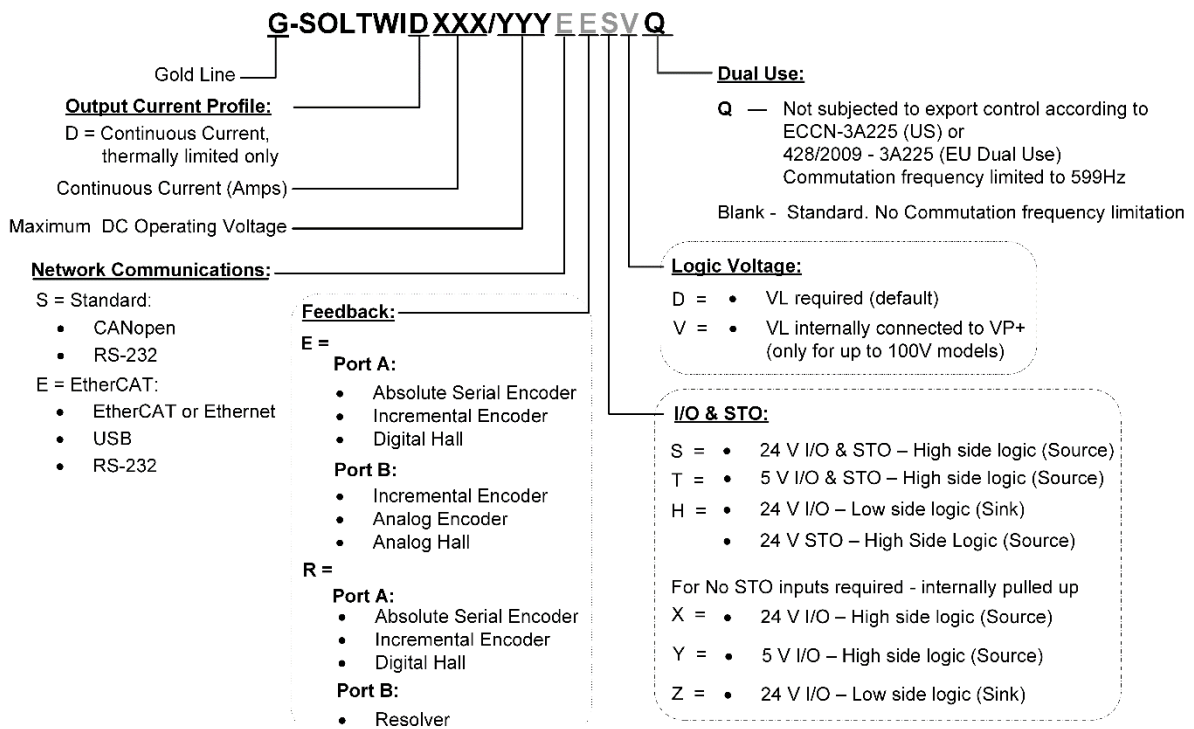

## Revision History

<b>Version</b>	<b>Date</b>
<b>Ver. 1.000</b>	Mar 2018
<b>Ver. 1.001</b>	Mar 2018
<b>Ver. 1.002</b>	Jul 2018
<b>Ver. 1.003</b>	Sep 2018
<b>Ver. 1.004</b>	Dec 2018
<b>Ver. 1.005</b>	May 2019
<b>Ver. 1.006</b>	Jan 2021
<b>Ver. 1.007</b>	May 2021
<b>Ver. 1.008</b>	Sept 2021

<b>Chapter 1: This Installation Guide .....</b>	<b>7</b>
<b>Chapter 2: Safety Information .....</b>	<b>7</b>
2.1. Warnings .....	8
2.2. Cautions.....	8
2.3. Warranty Information .....	8
<b>Chapter 3: Product Description.....</b>	<b>9</b>
<b>Chapter 4: Technical Information.....</b>	<b>10</b>
4.1. Physical Specifications.....	10
4.2. D Type Technical Data .....	10
4.3. Control Supply Input Voltage (VL).....	11
4.4. Product Features .....	11
4.5. Environmental Conditions.....	12
<b>Chapter 5: Standards and Certification .....</b>	<b>13</b>
5.1. CE Declaration .....	14
5.2. Environmental .....	14
5.3. EMC .....	14
5.4. EtherCAT Conformance .....	14
5.5. Dual Use .....	15
5.6. Other Compliant Standards.....	15
<b>Chapter 6: Installation.....</b>	<b>16</b>
6.1. Unpacking the Servo Drive Components.....	16
6.2. Mounting the Gold Solo Double Twitter to a Heat Sink.....	17
6.3. The Gold Solo Double Twitter Connection Diagrams.....	18
6.3.1. CAN Connection Diagram .....	18
6.3.2. EtherCAT Connection Diagram.....	19
<b>Chapter 7: Wiring.....</b>	<b>20</b>
7.1. Wiring Legend.....	20
7.2. Connectors Types .....	22
7.2.1. Recommended Cable Lugs and Cabling.....	23
7.3. Mating Connectors, Wires, and Cables .....	23
7.4. Logic and Control Cabling and Wiring .....	24
7.4.1. J10 and J11 (Feedback ports, VL, RS232, USB, Analog Input).....	24
7.4.2. J11 (Digital Inputs/Outputs, STO).....	24

7.4.3.	J17, J18 EtherCAT or CAN Communication.....	24
7.4.4.	COMRET to PE Connection .....	24
7.5.	Wiring the Female Connectors.....	25
<b>Chapter 8:</b>	<b>Connections .....</b>	<b>26</b>
8.1.	Main, Control, and Motor Power .....	26
8.1.1.	Connecting the DC Power and the Motor Power Wires.....	26
8.1.2.	Motor Power Connections .....	27
8.1.3.	Motor Power .....	28
8.1.4.	Main Power and Control Supply.....	30
8.1.4.1.	Main Power .....	30
8.1.4.2.	Control Supply (J10).....	31
8.1.4.3.	Dual Power Supply (PN G-SOLTWIDXXX/YYYYESD) .....	32
8.1.4.4.	Single Power Supply (PN G-SOLTWIDXXX/YYYYESV) .....	34
8.2.	Drive Status Indicator .....	35
8.3.	J10 VL and Feedback Connector.....	36
8.3.1.	Port A.....	39
8.3.1.1.	Incremental Encoder .....	39
8.3.1.2.	Absolute Serial Encoder.....	40
8.3.1.3.	Hiperface .....	41
8.3.1.4.	Hall Sensors .....	42
8.3.2.	Port B.....	43
8.3.2.1.	Incremental Encoder .....	43
8.3.2.2.	Interpolated Analog Encoder .....	43
8.3.2.3.	Resolver .....	44
8.3.3.	Port C – Emulated Encoder Output (J10).....	44
8.4.	J11 I/O and Communication Connector .....	45
8.4.1.	Digital Inputs.....	48
8.4.1.1.	Source PLC Voltage Level Digital Input.....	48
8.4.1.2.	Sink PLC Voltage Level Digital Input .....	50
8.4.1.3.	Source 5V Logic Level Digital Input.....	52
8.4.2.	Digital Outputs.....	54
8.4.2.1.	Source PLC Voltage Level Digital Output.....	54
8.4.2.2.	Sink PLC Voltage Level Digital Output .....	56
8.4.2.3.	Digital Outputs Source 5V Logic Mode.....	58
8.4.3.	STO (Safe Torque Off).....	60
8.4.4.	Analog Input .....	61

8.4.5.	Standard RS-232 .....	61
8.4.6.	USB 2.0 Communication (Only for EtherCAT version).....	62
8.5.	EtherCAT Communications Version .....	63
8.5.1.	EtherCAT IN/Ethernet Connector (J17) .....	63
8.5.2.	EtherCAT OUT Connector (J18) .....	64
8.5.3.	EtherCAT Option.....	65
8.5.3.1.	EtherCAT Communication .....	65
8.5.3.2.	EtherCAT Status Indicator (D2).....	66
8.5.3.3.	EtherCAT Link Indicators (D3, D4) .....	66
8.6.	CAN Communications Version .....	67
8.6.1.	CAN IN Connector (J17) .....	67
8.6.2.	CAN OUT Connector (J18).....	68
8.6.3.	CAN Option.....	69
8.6.3.1.	Interface .....	69
8.6.3.2.	CAN Layout .....	70
<b>Chapter 9:</b>	<b>Powering Up .....</b>	<b>71</b>
9.1.	Initializing the System .....	71
9.2.	Heat Dissipation .....	71
9.2.1.	Heat Dissipation Data .....	71
9.2.2.	How to Use the Chart .....	73
<b>Chapter 10:</b>	<b>Dimensions .....</b>	<b>75</b>
<b>Chapter 11:</b>	<b>Cables and Accessories .....</b>	<b>77</b>



## Chapter 1: This Installation Guide

This installation Guide details the technical data, pinouts, and power connectivity of the Gold Solo Double Twitter. For a comprehensive detailed description of the functions and connections of the drive, refer to the Gold Panel Mounted Drives Hardware Manual.

## Chapter 2: Safety Information

In order to achieve the optimum, safe operation of the Gold Solo Double Twitter, it is imperative that you implement the safety procedures included in this installation guide. This information is provided to protect you and to keep your work area safe when operating the Gold Solo Double Twitter and accompanying equipment.

**Please read this chapter carefully before you begin the installation process.**

Before you start, ensure that all system components are connected to earth ground. Electrical safety is provided through a low-resistance earth connection.

Only qualified personnel may install, adjust, maintain and repair the servo drive. A qualified person has the knowledge and authorization to perform tasks such as transporting, assembling, installing, commissioning and operating motors.

The Gold Solo Double Twitter contains electrostatic-sensitive components that can be damaged if handled incorrectly. To prevent any electrostatic damage, avoid contact with highly insulating materials, such as plastic film and synthetic fabrics. Place the product on a conductive surface and ground yourself in order to discharge any possible static electricity build-up.

To avoid any potential hazards that may cause severe personal injury or damage to the product during operation, keep all covers and cabinet doors shut.

The following safety symbols are used in this and all Elmo Motion Control manuals:



**Warning:**

This information is needed to avoid a safety hazard, which might cause bodily injury or death as a result of incorrect operation.



**Caution:**

This information is necessary to prevent bodily injury, damage to the product or to other equipment.



**Important:**

Identifies information that is critical for successful application and understanding of the product.



## 2.1. Warnings

- To avoid electric arcing and hazards to personnel and electrical contacts, never connect/disconnect the servo drive while the power source is on.
- Power cables can carry a high voltage, even when the motor is not in motion. Disconnect the Gold Solo Double Twitter from all voltage sources before servicing.
- The high voltage products within the Gold Line range contain grounding conduits for electric current protection. Any disruption to these conduits may cause the instrument to become hot (live) and dangerous.
- After shutting off the power and removing the power source from your equipment, wait at least 3 minutes before touching or disconnecting parts of the equipment that are normally loaded with electrical charges (such as capacitors or contacts). Measuring the electrical contact points with a meter, before touching the equipment, is recommended.



## 2.2. Cautions

- The maximum DC power supply connected to the instrument must comply with the parameters outlined in this guide.
- When connecting the Gold Solo Double Twitter to an approved control supply, connect it through a line that is separated from hazardous live voltages using reinforced or double insulation in accordance with approved safety standards.
- Before switching on the Gold Solo Double Twitter, verify that all safety precautions have been observed and that the installation procedures in this manual have been followed.
- Make sure that the Safe Torque Off is operational

## 2.3. Warranty Information

The products covered in this manual are warranted to be free of defects in material and workmanship and conform to the specifications stated either within this document or in the product catalog description. All Elmo drives are warranted for a period of 12 months from the time of shipment. No other warranties, expressed or implied — and including a warranty of merchantability and fitness for a particular purpose — extend beyond this warranty.





## Chapter 3: Product Description

The Ultra High Current Gold Solo Double Twitter which can deliver 180A @ up to 55VDC, 160A @ up to 75VDC, 140A @ up to 95VDC, and 70A @ up to 195VDC, are advanced high power density servo drives, delivering up to **11 kW power** in a 97.02 cm<sup>3</sup>(5.92 Inch<sup>3</sup>) compact package 47 x 69.5 x 29.7 mm (1.85" x 2.74" x 1.17").

This advanced, high power density servo drive provides top performance, advanced networking and built-in safety, as well as a fully featured motion controller and local intelligence. Power to the Gold Solo Double Twitter is provided by a DC power source which is isolated from the Mains. The Gold Solo Double Twitter can operate with single or dual power supplies. If separation between the main DC power source and a control supply is required, then a control supply (isolated from the Mains) is required according to the Part Number.

The drive can operate as a stand-alone device or as part of a multi-axis system in a distributed configuration on a real-time network.

The Gold Solo Double Twitter drive is easily set up and tuned using the Elmo Application Studio (EASII) software tools. As part of the Gold product line, it is fully programmable with the Elmo motion control language. For more information about software tools refer to the Elmo Application Studio (EASII) User Guide.

The Gold Solo Double Twitter is available in a variety of models. There are multiple power rating options, different communications options, a number of feedback options and different I/O configuration possibilities.

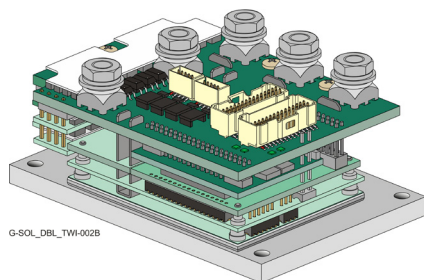

**EtherCAT**

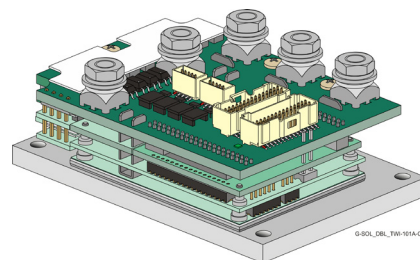

**CANopen**

**Figure 1: Difference between 4-Tier EtherCAT and 3-Tier CANopen modules**



## Chapter 4: Technical Information

### 4.1. Physical Specifications

Feature	Units	All Types
Weight	g (oz)	~120.0 g (4.23 oz)
EtherCAT Version Dimension	mm (in)	47 x 69.5 x 29.7 mm (1.85" x 2.74" x 1.17")
CAN Version Dimension	mm (in)	47 x 69.5 x 26.9 mm (1.85" x 2.74" x 1.06")
<b>Mounting method</b>		Panel Based Mounting

### 4.2. D Type Technical Data

Feature	Units	D180/60	D160/80	D140/100	D40/200	D70/200
Minimum supply voltage	VDC	11	11	11	20	20
Nominal supply voltage	VDC	45	65	85	170	170
Maximum supply voltage	VDC	55	75	95	195	195
Maximum continuous Electrical power output	kW	8.6	10	11	6.4	11
Efficiency at rated power (at nominal conditions)	%	> 99				
Maximum output voltage		Up to 96% of DC bus voltage				
Amplitude sinusoidal continuous current	A	180	160	140	40	70
Sinusoidal continuous RMS current limit (I <sub>c</sub> )	A	127	113	99	28	49
Current limit	A	Max Output current is guaranteed for T <sub>Heat-Sink</sub> <85°C				



### 4.3. Control Supply Input Voltage (VL)

The Control Supply input voltage (VL) must be either SELV or PELV rated.

Feature	Unit	Details
<b>Standard CAN (S option)</b>		
Input range	V	11 V – 95 V
Power consumption (including 5 V/200 mA for encoder)	W	< 2.5 W
<b>ETHERCAT (E option)</b>		
Input range	V	11 V – 95 V
Power consumption (including 5 V/200 mA for encoder)	W	< 4 W

### 4.4. Product Features

Main Feature	Details	Presence / No.
<b>STO</b>	+5V Logic, Opto isolated from the Control section, <i>or</i>	✓
	PLC Source, Opto isolated from the Control section	✓
<b>Digital Input</b>	+5V Logic, Opto isolated from the Control section <i>or</i>	6
	PLC Source, Opto isolated from the Control section <i>or</i>	6
	PLC Sink Opto isolated from the Control section	6
<b>Digital Output</b>	+5V Logic, Opto isolated from the Control section <i>or</i>	4
	PLC Source, Opto isolated from the Control section <i>or</i>	4
	PLC Sink, Opto isolated from the Control section	4
<b>Analog Input</b>	Differential ±10V or Single Ended	1
<b>Feedback</b>	Standard Port A, B, and C	✓
<b>Communication Option</b>	USB (only for EtherCAT version)	✓
	EtherCAT <i>or</i>	✓
	CAN	✓
	Standard RS232	✓



### 4.5. Environmental Conditions

You can guarantee the safe operation of the Gold Solo Double Twitter by ensuring that it is installed in an appropriate environment.



**Warning:** During operation the Gold Solo Double Twitter becomes hot to the touch (the heatsink and wires may heat up to 92 °C). Care should be taken when handling it.



**Caution:** The Gold Solo Double Twitter dissipates its heat by convection or by conduction. The maximum ambient operating temperature of 50 °C (122°F) must not be exceeded.

Feature	Details
<b>Operating ambient temperature in compliance with STO standards</b>	0 °C to 40 °C (32 °F to 104 °F)
<b>Operating ambient temperature according to IEC60068-2-2</b>	0 °C to 50 °C (32 °F to 122 °F) in compliance with UL standards
<b>Storage temperature</b>	-20 °C to +85 °C ( -4 °F to +185 °F)
<b>Maximum non-condensing humidity according to IEC60068-2-78</b>	95%
<b>Maximum Operating Altitude</b>	2,000 m (6562 feet) It should be noted that servo drives capable of higher operating altitudes are available on request.
<b>Mechanical Shock according to IEC60068-2-27</b>	15g / 11ms Half Sine
<b>Vibration according to IEC60068-2-6</b>	5 Hz ≤ f ≤ 10 Hz: ±10mm 10 Hz ≤ f ≤ 57 Hz: 4G 57 Hz ≤ f ≤ 500 Hz:5G



## Chapter 5: Standards and Certification

The following table describes the Main Standards of the Gold Solo Double Twitter servo drive. For further details refer to the MAN-G-Panel Mounted Drives Hardware manual.

Safe Torque Off (STO) Safety Standard	Item
The related functional safety standards below apply to the performance of the servo drives as stated in the environmental conditions in the section above.	
In Compliance with <b>STO IEC 61800-5-2:2007 SIL 3</b>	Adjustable speed electrical power drive systems – Safety requirements – Functional
In Compliance with <b>EN ISO 13849-1:2008 PL e, Cat 3</b>	Safety of machinery – Safety-related parts of control systems.
In Compliance with <b>EN 61508-1:2010 SIL 3</b>	Functional safety of electrical/electronic/ programmable electronic safety-related systems
In Compliance with <b>EN 61508-2:2010 SIL 3</b>	Functional safety of electrical/electronic/ programmable electronic safety-related systems
In Compliance with <b>EN 61508-3:2010 SIL 3</b>	Functional safety of electrical/electronic/ programmable electronic safety-related systems

Safety	Item
The related safety standards below apply to the performance of the servo drives as stated in the environmental conditions in section above.	
In compliance with <b>IEC/EN 61800-5-1</b>	Adjustable speed electrical power drive systems Safety requirements – Electrical, thermal and energy
In compliance with <b>UL61800-5-1</b>	Adjustable speed electrical power drive systems Safety requirements – Electrical, thermal and energy
In compliance with <b>CSA C22.2 NO. 14-13</b> Or In compliance with <b>CSA C22.2 NO. 274-13</b>	Industrial Control Equipment Adjustable drive speeds



### 5.1. CE Declaration

Refer to the complete EC Declaration of Conformity available on the internet at:

<https://www.elmomc.com/download/4443/Gold-Line-CE-Declaration-of-Conformity-1.pdf>

### 5.2. Environmental

Specification	Details
In compliance with IEC60068-2-78	Environmental testing – Damp heat, steady state
In compliance with IEC60068-2-6	Environmental testing –Vibration (sinusoidal)
In compliance with IEC60068-2-2	Environmental testing – Dry heat
In compliance with IEC60068-2-27	Basic environmental testing procedures - Shock

### 5.3. EMC

Specification	Details
In compliance with IEC/EN 61800-3	Adjustable speed electrical power drive systems
In compliance with EN 55011 Class A with EN 61000-6-2: Immunity for industrial environment, according to: IEC 61000-4-2 / criteria B IEC 61000-4-3 / criteria A IEC 61000-4-4 / criteria B IEC 61000-4-5 / criteria B IEC 61000-4-6 / criteria A IEC 61000-4-8 / criteria A IEC 61000-4-11 / criteria B/C	Electromagnetic compatibility (EMC)
In compliance with IEC 61326-3-1	Electrical equipment for measurement, control and laboratory use. Standard required for STO.

### 5.4. EtherCAT Conformance

EtherCAT Conformance Test Certified
Approved and certified EtherCAT conformance



### 5.5. Dual Use

No export license is required for the Gold Line products signified with the suffix Q in the Part Number.

The operating frequency of the Gold Line products is “factory limited” to ≤ 599 Hz, and therefore complies with the EU Dual Use Regulation 428/2009, 3A225, and the US Dual Use regulation EAR ECCN# 3A225.

This statement applies to all identical specimens and will become invalid if a change is made in the firmware.

### 5.6. Other Compliant Standards

Quality Assurance	
ISO 9001:2015	Quality Management
Design	
<ul style="list-style-type: none"> <li>• IPC-D-275</li> <li>• IPC-SM-782</li> <li>• IPC-CM-770</li> </ul>	Printed wiring for electronic equipment (clearance, creepage, spacing, conductors sizing, etc.)
Reliability	
MIL-HDBK- 217F	Reliability prediction of electronic equipment (rating, de-rating, stress, etc.)
Workmanship	
IPC-A-610, level 3	Acceptability of electronic assemblies
PCB	
IPC-A-600, level 3	Acceptability of printed circuit boards
Packing	
EN 100015	Protection of electrostatic sensitive devices
Environmental	
WEEE Directive 2012/19/EC	Waste Electrical and Electronic Equipment regulations (WEEE) <b>Note:</b> Out-of-service Elmo drives should be sent to the nearest Elmo sales office.
ROHS Directives 2011/65/EU and 2015/863	Restrictions on Application of Hazardous Substances in Electric and Electronic Equipment (RoHS)



## Chapter 6: Installation

### 6.1. Unpacking the Servo Drive Components

Before you begin working with the Gold Solo Double Twitter, verify that you have all of its components, as follows:

- The Gold Solo Double Twitter servo drive
- The Elmo Application Studio (EASII) software and software manual

The Gold Solo Double Twitter is shipped in a cardboard box with Styrofoam protection.

#### To unpack the Gold Solo Double Twitter:

1. Carefully remove the servo drive from the box and the Styrofoam.
2. Check the drive to ensure that there is no visible damage to the instrument. If any damage has occurred, report it immediately to the carrier that delivered your drive.
3. To ensure that the Gold Solo Double Twitter you have unpacked is the appropriate type for your requirements, locate the part number sticker on the top of the Gold Solo Double Twitter. It looks like this:

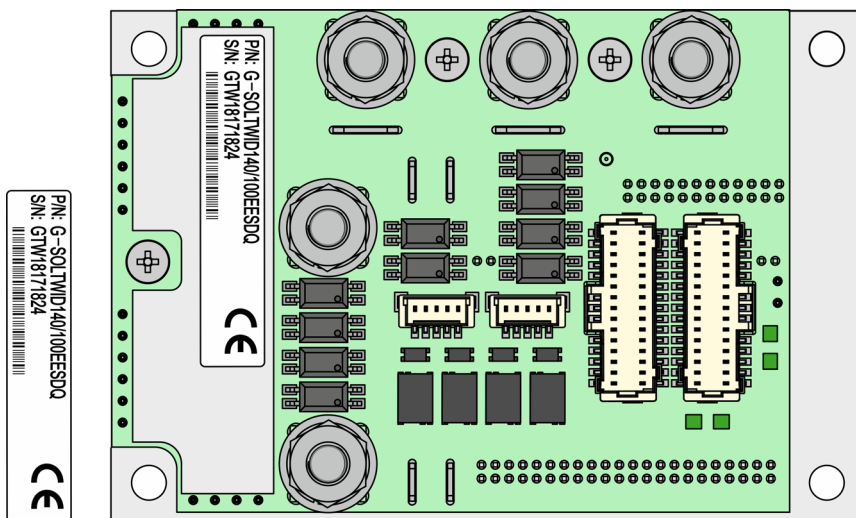

G-SOL\_DBL\_TWI-B\_009F

4. Verify that the Gold Solo Double Twitter type is the one that you ordered, and ensure that the voltage meets your specific requirements.

The part number at the top provides the type designation. Refer to the appropriate part number in the section Catalog Number at the beginning of the installation guide.





## 6.2. Mounting the Gold Solo Double Twitter to a Heat Sink

The selected heat sink must be screwed to the lower surface of the Gold Solo Double Twitter.

### To mount the heat sink:

1. Mount the heat sink under the base of the Gold Solo Double Twitter.
2. Place the Thermal foil (PN IMT-DTWIALHFLAT purchased from Elmo) between the lower surface of the servo drive, and the upper surface of the heat sink
3. Use four M3 head cup Allen screws to secure the heat sink under the servo drive.
4. Tighten the screws to the relevant torque force applicable to an M3 stainless steel A2 screw.

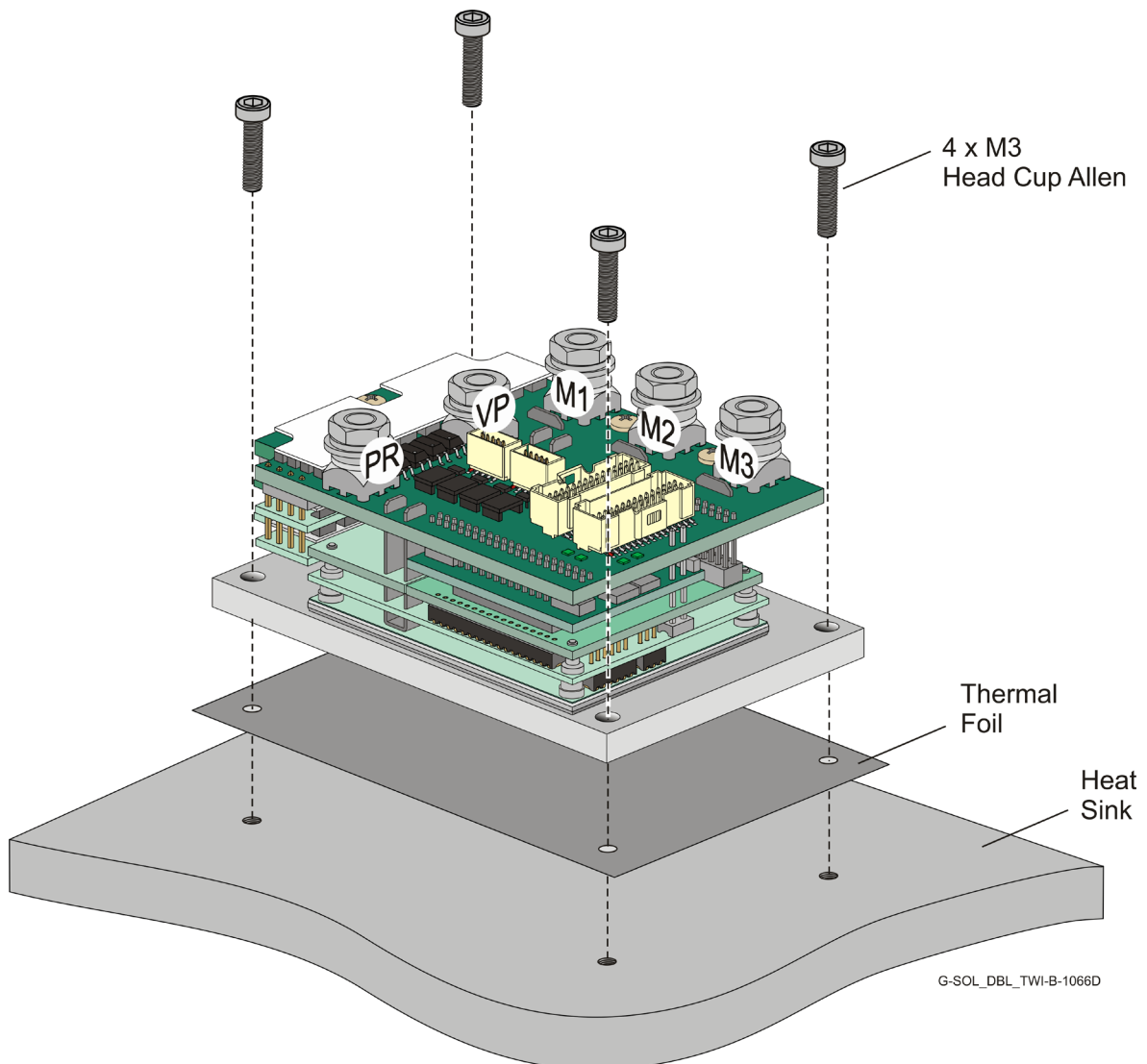
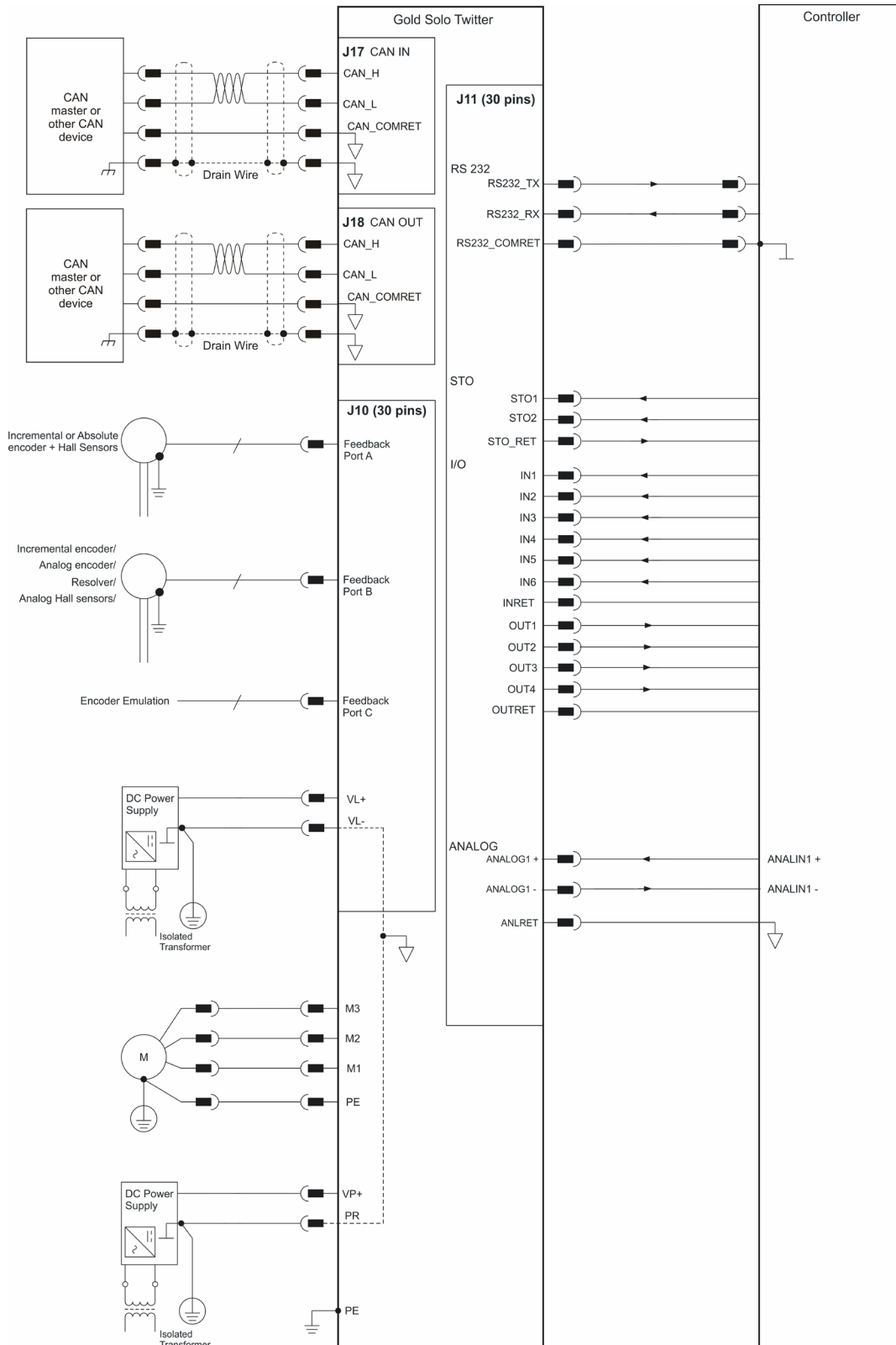

Figure 2: Mount the Heat Sink and Thermal Foil to the Gold Solo Double Twitter



## 6.3. The Gold Solo Double Twitter Connection Diagrams

### 6.3.1. CAN Connection Diagram



G-SOL\_TWID\_CAN-F

Figure 3: The Gold Solo Double Twitter CAN Connection Diagram



### 6.3.2. EtherCAT Connection Diagram

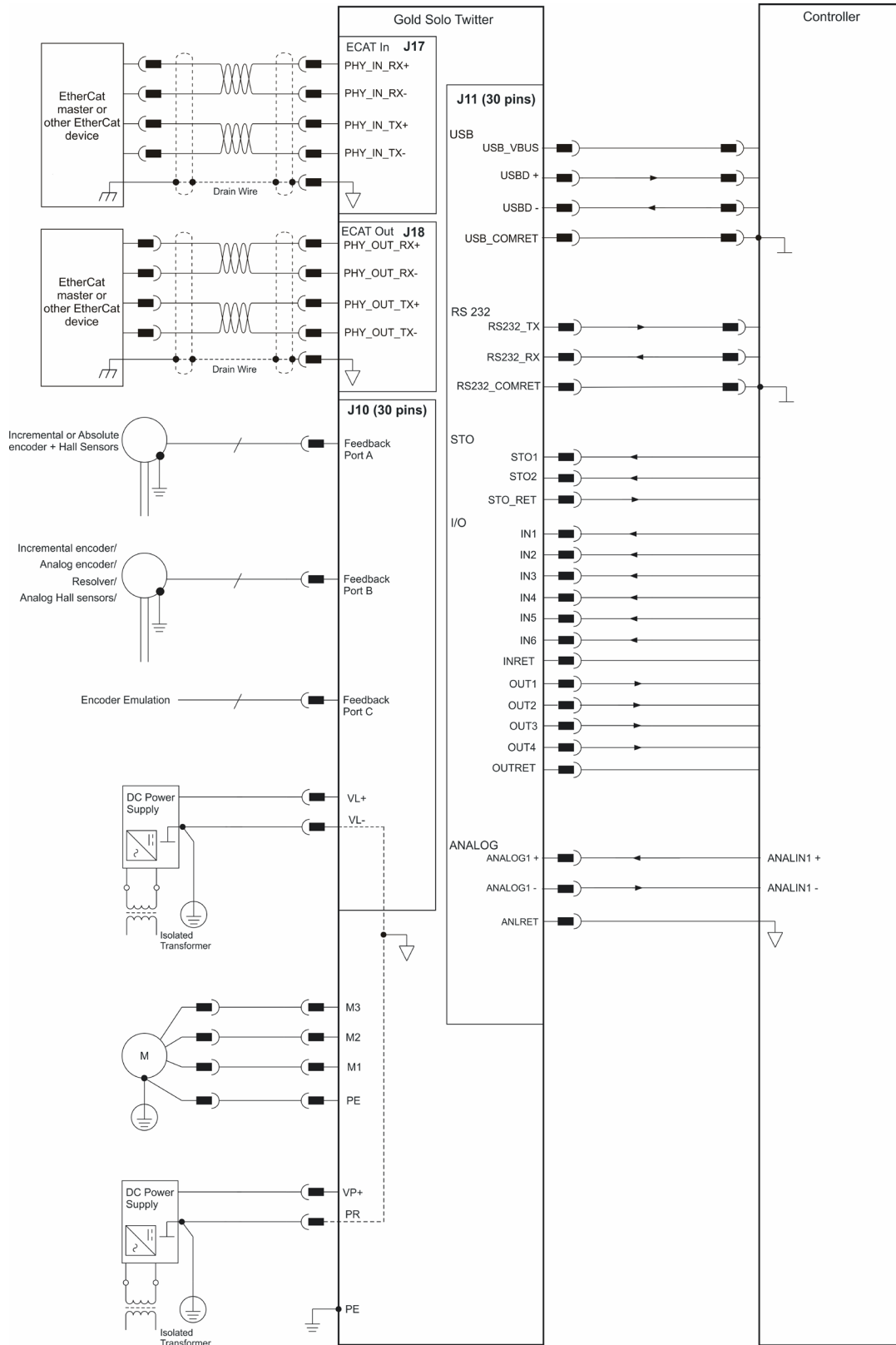

G-SOL\_TWID-001G

Figure 4: The Gold Solo Double Twitter EtherCAT Connection Diagram



## Chapter 7: Wiring

### 7.1. Wiring Legend

The following table legend describes the wiring symbols detailed in all installation guides. All the wiring diagrams show wiring for D-TYPE connectors.

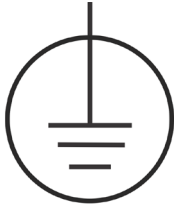
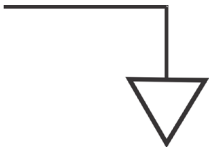
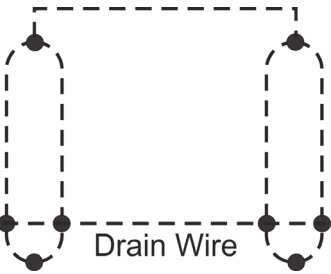
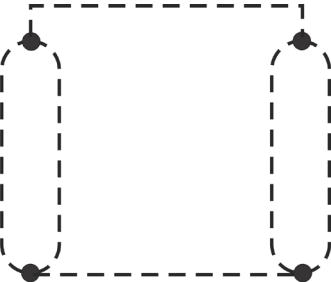
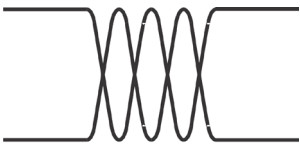
Wiring Symbol	Description
 GGEN_101D-A	Earth connection (PE)
 GGEN_101D-B	Protective Earth Connection
 GGEN_101D-C	Common at the Controller
 GGEN_101D-D	Shielded cable with drain wire. The drain wire is a non-insulated wire that is in direct contact with the braid (shielding). Shielded cable with drain wire significantly simplifies the wiring and earthing.
 GGEN_101D-E	Shielded cable braid only, without drain wire.
 GGEN_101D-F	Twisted-pair wires

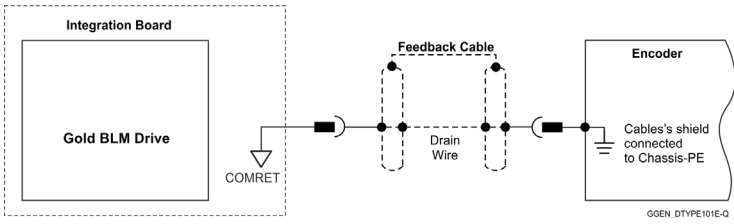

Wiring Symbol	Description
 <p>The diagram illustrates the wiring for encoder earthing. On the left, an 'Integration Board' contains a 'Gold BLM Drive' with a 'COMRET' terminal. A 'Feedback Cable' with a 'Drain Wire' is connected between the drive and an 'Encoder'. The encoder's shield is connected to 'Chassis-PE'. The diagram is labeled 'GGEN_DTYPPE101E-Q'.</p>	<p><b>Encoder Earthing.</b></p> <p>The cable's shield is connected to the chassis (PE) in the connector.</p> <p>Earthing the Encoder and connecting the Earth (PE) to the drive COMRET is mandatory to insure reliable operation, high noise immunity and rejection of voltage common mode interferences.</p>



## 7.2. Connectors Types

The Gold Solo Double Twitter has the following types of connectors.

Type	Function	Port	Connector Location
Terminal Lug + M4 Flat Washer + M4 Spring Washer + M4 Nut	Power	VP+, PR	
	Motor	M1, M2, M3	
Terminal Lug + M3 Flat Washer + M3 Spring Washer + M3 screw	Earth Connection	PE, PE	

Recommended for M4 screw

Terminal Lug (FLEX) Stud hall size: M4

### Connectors Location

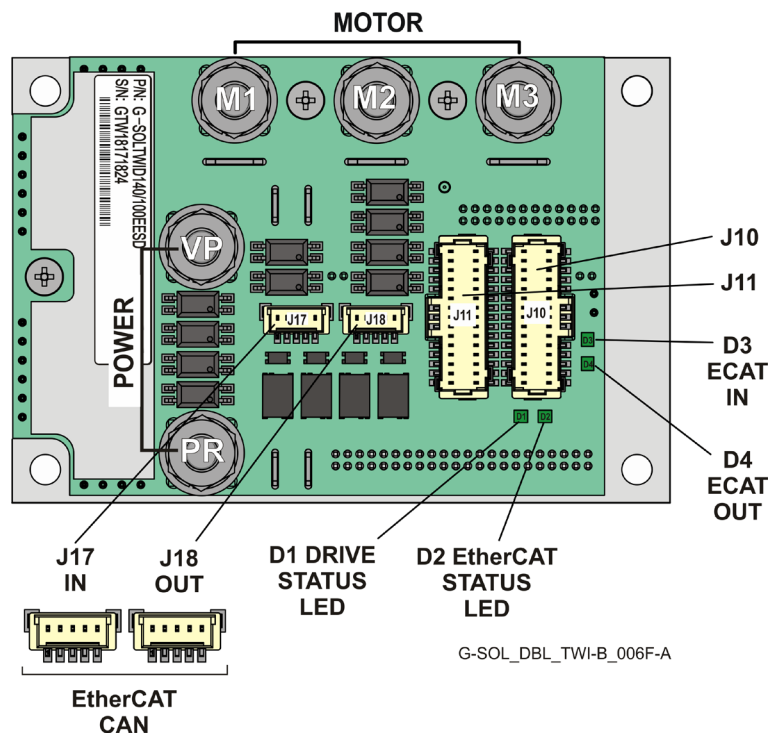



Pins	Type	Function
	Redcube Terminal screw, M4 Flat Washer, M4 Spring Washer, and M4 Nut	Power, Motor
2 rows x 15 Pins	Molex type	J10 - VL & Feedback Ports
2 rows x 15 Pins	Molex type	J11 - IO and Communication
<b>EtherCAT/CAN</b>		
5	Molex type	J17 - CAN/EtherCAT IN Communication
5	Molex type	J18 - CAN/EtherCAT OUT Communication

### 7.2.1. Recommended Cable Lugs and Cabling

Elmo recommends the following cable lugs depending on the cable to be installed. Refer to the specification drawings for the UL listed lug and cable application.

#### Copper Lug - One-Hole, Standard Flex Barrel 6, 8, 10, 12 Gauge

Current (A) (Up to)	Wire Type	Stud Size
180	#6 AWG	M4(#8)
100	#8 AWG	M4(#8)
70	#10 AWG	M4(#8)
40	#12 AWG	M4(#8)

For best noise immunity, twist the DC power wires.

Do not twist or bundle the motor phase wires.

### 7.3. Mating Connectors, Wires, and Cables

Connector	Mating Connector Type	Mating Crimping Pins
<b>J10, J11 VL &amp; Feedback Ports IO and Communication</b>	MOLEX 1.00mm "Pico-Clasp" 501189-3010	MOLEX 1.00mm crimp terminal 501193-3000
<b>J17, 18 IN/OUT CAN/EtherCAT Communication</b>	MOLEX 1.00mm "Pico-Clasp" 501330-0500	MOLEX 1.00mm crimp terminal 501334-0100



## 7.4. Logic and Control Cabling and Wiring

### 7.4.1. J10 and J11 (Feedback ports, VL, RS232, USB, Analog Input)

For short distances between the drive and control, 0.5 to 1.0 m wires can be used and shielding is not required. For longer distances than 1.0 m and/or high EMI environment, shielded and twisted wires should be used. Drain wires should be connected to Elmo COMRET.

### 7.4.2. J11 (Digital Inputs/Outputs, STO)

Wires can always be used, no need for twisting, no need for shielding.

### 7.4.3. J17, J18 EtherCAT or CAN Communication

Always use CAT5e cables

(see Elmo's Gold Solo Double Twitter Cable Kit (MAN-G-SOLO\_DOUBLE\_TWITTER\_CBLKIT)).

### 7.4.4. COMRET to PE Connection

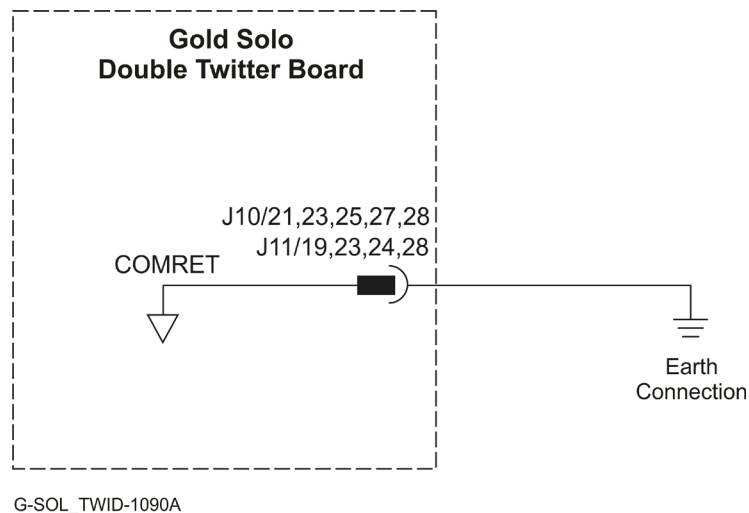

Figure 5: COMRET Connection to the PE

**At least one COMRET pin (Figure 5) must be connected to the Protective Earth (PE).**

Earthing the COMRET by connecting the Earth (PE) to the drive COMRET is mandatory to insure reliable operation, high noise immunity and rejection of voltage common mode interferences.





## 7.5. Wiring the Female Connectors

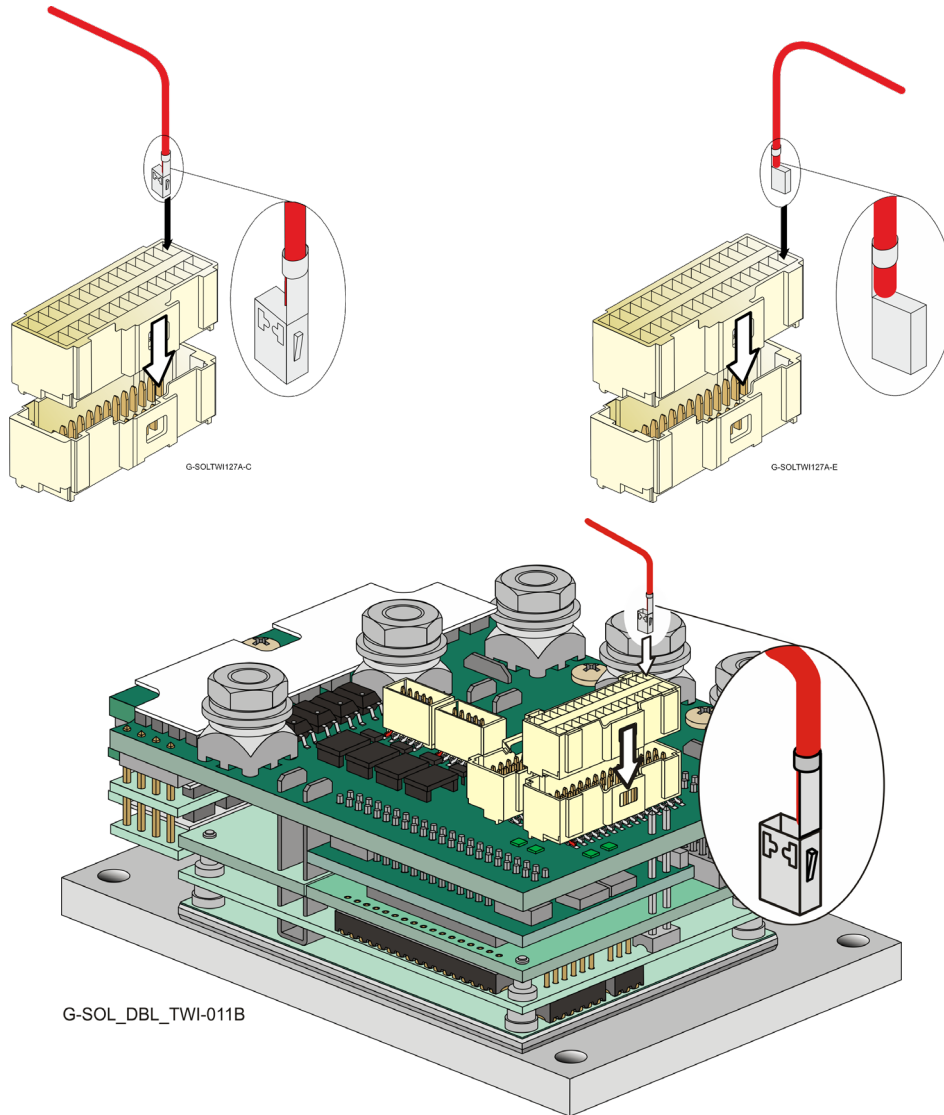

**Figure 6: Inserting a wire/pin to the Female Connector**

To insert a wire/pin to the female connectors of J10, J11, J17, and J18 do the following:

1. Select the relevantly colored wire to insert to a specific rectangular compartment on the female connector.
2. Use the appropriate Molex crimping plier (Molex P/N 63819-1500) to fasten a pin connector to the end of the wire.
3. Place the connector on a flat surface, in the orientation as shown in Figure 6. Notice that the rectangular slot has a niche at the bottom of the slot.
4. Insert the wire connector to the slot as shown in Figure 6. Make sure that the connector protrusion is inserted to the bottom of the rectangular slot. When inserting the wire connector to a slot in the second row, make sure to rotate the connector in the opposite orientation.
5. Repeat the same procedure for any other wire connections.



## Chapter 8: Connections

### 8.1. Main, Control, and Motor Power

This section describes the Main and Control supplies, and Motor Power connections. The Motor and Main Power interface uses lugs and cables defined in section 7.2.1 Recommended Cable Lugs and Cabling.

#### 8.1.1. Connecting the DC Power and the Motor Power Wires

This section describes the installation of the wire terminal lugs for both the Main Power wires to VP+, PR, and PE terminals on the Gold Solo Double Twitter, and the Motor Power wires to the M1, M2, M3, and PE terminals on the Gold Solo Double Twitter.

**Note:** When connecting several identical motors, all the motor phases must be connected in an identical sequence in order to save repetition of the tuning process.

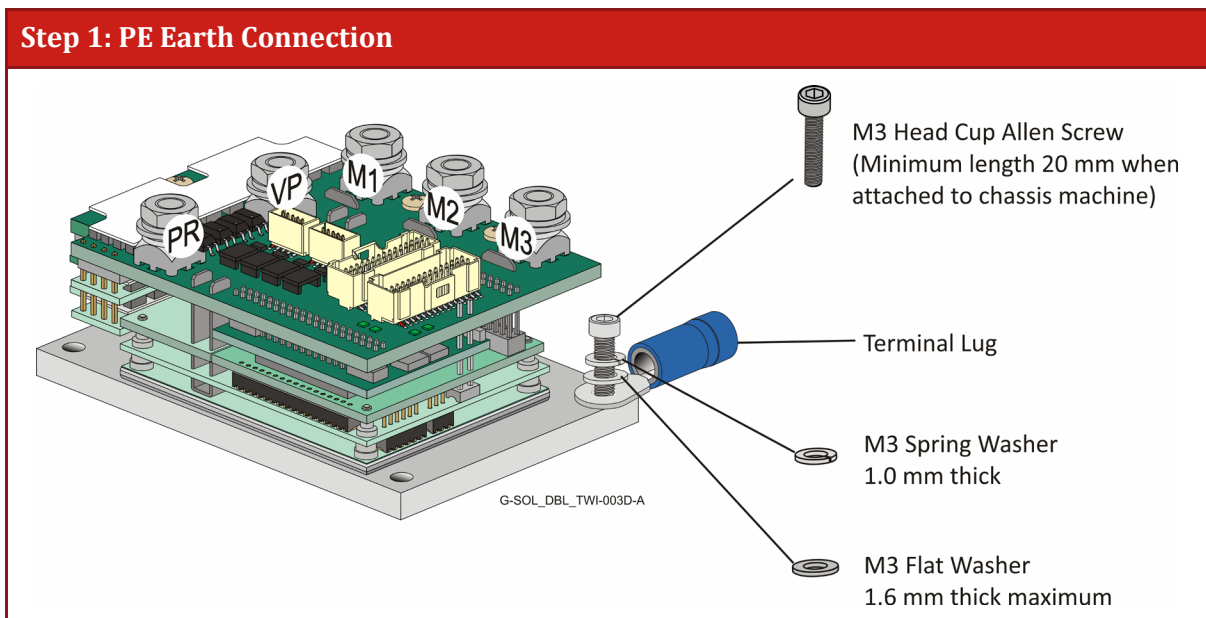

Tighten the screw to the relevant torque force applicable to an M3 stainless steel A2 screw.



## Step 2: Power and Motor Connection

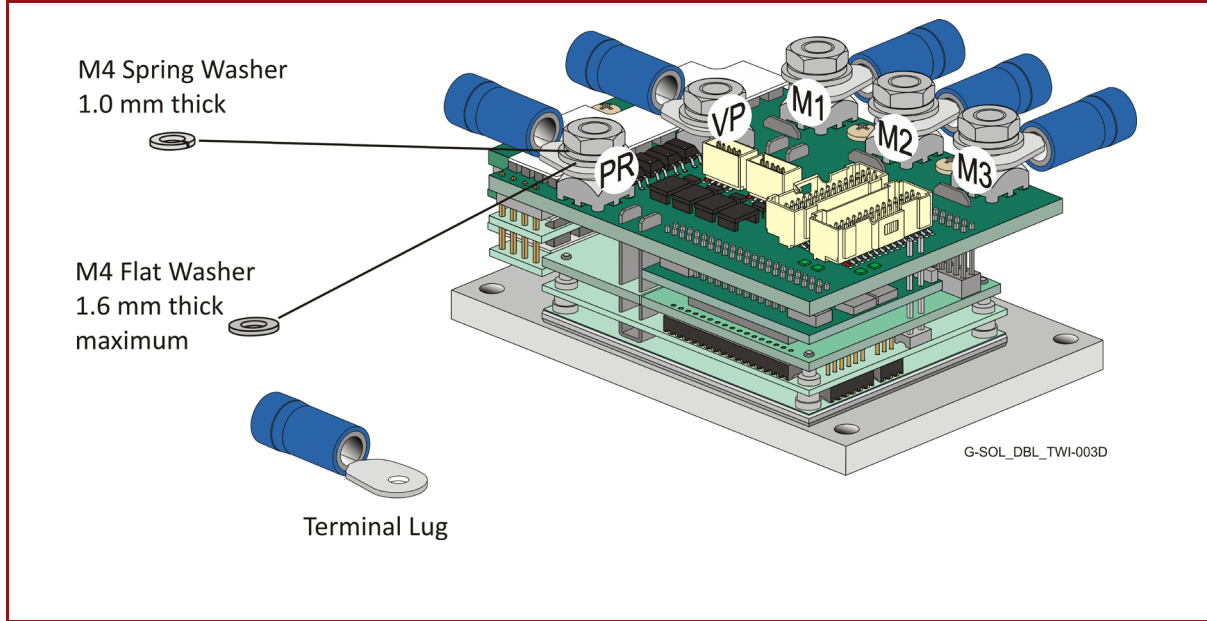

**Table 1: Connecting the Main Power and Motor Cables**

### 8.1.2. Motor Power Connections

1. Ensure that the motor chassis is properly earthed.
2. Connect the appropriate terminal lugs from the Motor Power cables to the M1, M2, M3, and PE terminals on the Gold Solo Double Twitter.

The phase connection is arbitrary as Elmo Application Studio (EAS II) will establish the proper commutation automatically during setup. When tuning a number of drives, you can copy the setup file to the other drives and thus avoid tuning each drive separately. In this case the motor-phase order must be the same as on the first drive.

- a. Install the motor cable to the drive using the recommended Terminal Lug (FLEX), M4 flat washer, M4 spring washer, and secure with an M4 nut (to the drive). The required M4 nut torque is typically 1.2 Nm.
  - b. Install the recommended PE wire to the drive, using a barrel connector, M3 flat washer, M3 spring washer, and secure with an M3 head cup Allen screw to the heatsink. Tighten the screw to the relevant torque force applicable to an M3 stainless steel A2 screw.
3. For high EMI environment, it is highly recommended to use a 4-wire shielded (not twisted) cable for the motor connection. The gauge is determined by the actual RMS current consumption of the motor.  
Connect the cable shield to the closest ground connection at the motor end.  
For better EMI performance, the shield should be connected to Earth Connection (heat sink mounting holes).



### 8.1.3. Motor Power

For full details see Section 7.3 in the manual: MAN-G-Board Level Modules Hardware manual.

Pin	Function	Cable		Pin Positions
		Brushless Motor	Brushed DC Motor	
PE	Connection earth	Motor	Motor	<p style="text-align: right; font-size: small;">G-SOL_DBL_TWI-B_006F-D</p>
M1	Motor phase	Motor	N/C	
M2	Motor phase	Motor	Motor	
M3	Motor phase	Motor	Motor	

Table 2: Motor Terminals

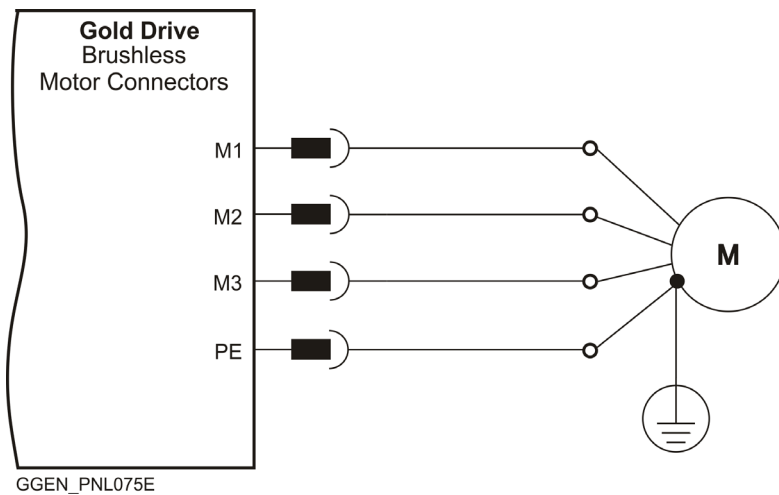

Figure 7: Brushless Motor Power Connection Diagram

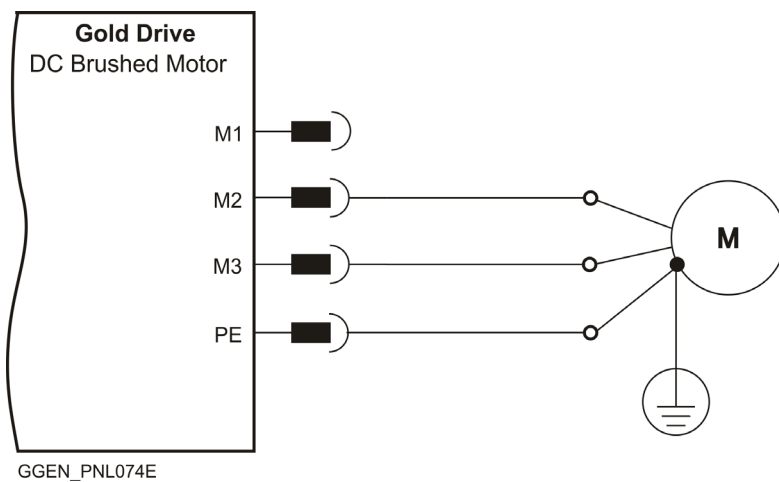

Figure 8: Brushed Motor Power Connection Diagram



Connect the motor power wires as shown in Figure 9. The Yellow wire is the Grounding wire. Make sure not to bundle the wires.

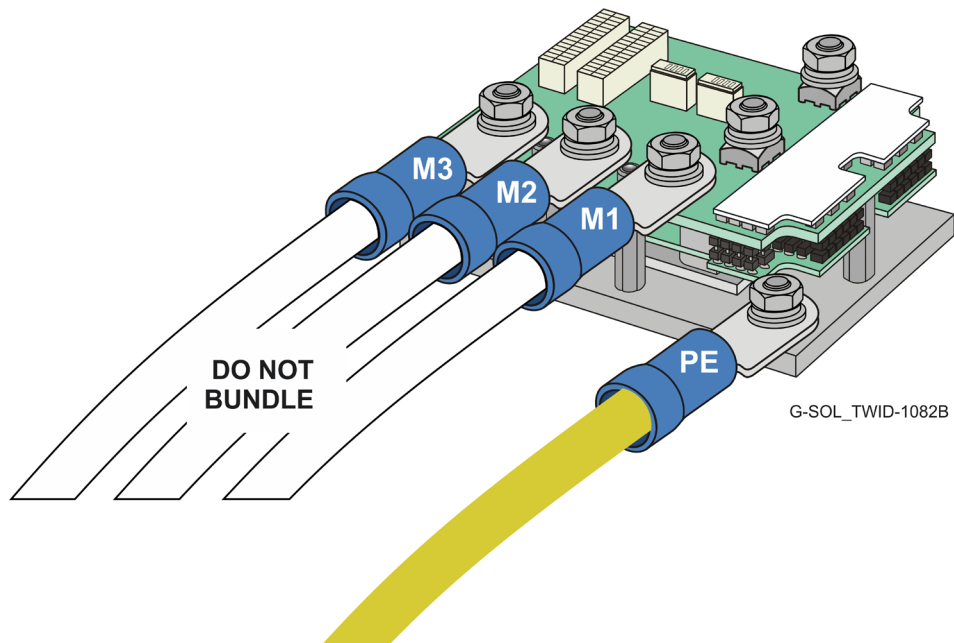

Figure 9: Connecting the Motor Power Wires



### 8.1.4. Main Power and Control Supply

This section describes the Main Power and the Control supply connector.

#### 8.1.4.1. Main Power

The isolated DC power source is not included with the Gold Solo Double Twitter.

Pin	Function	Cable	Pin Positions
VP+	DC Pos. Power input	Power	
PR	Power return	Power	
PE	Connection earth	Power	

Table 3: Main Power Terminals

Connect the DC power cable to the VP+ and PR terminals on the main power connector.

#### To connect the Gold Solo Double Twitter to the DC power source:

1. The source of the VDC power supply must be isolated from the Mains.
2. Verify that the rectified VDC is indeed within the range of the drive.
3. Connect the VP+ and PR wires to the terminals on the servo-drive as shown in Figure 10. It is highly recommended to twist the two DC main power cables at intervals of 10 cm.

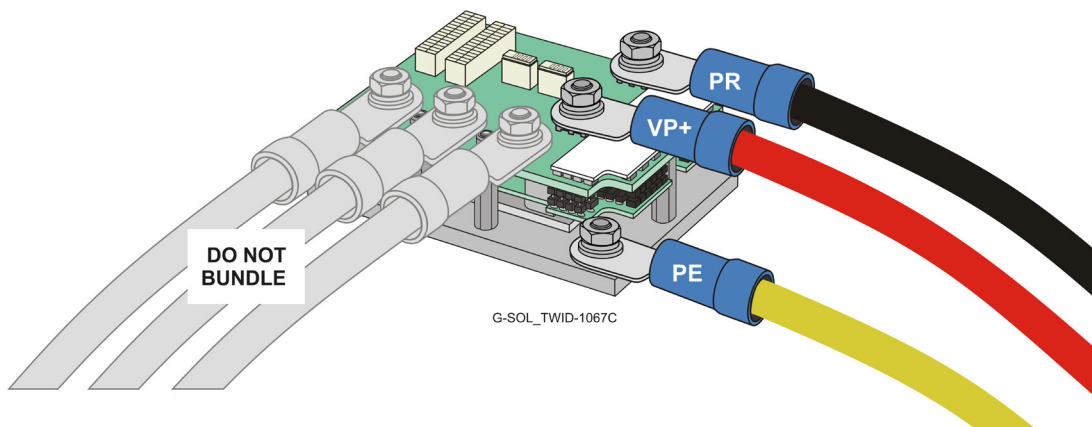

Figure 10: Connecting the Main Power Wires

4. Connect the PE to the closest earth connection near the power supply.
5. Connect the PR to the closest earth connection near the power supply.
6. Before applying power, first verify the polarity of the connection.



### 8.1.4.2. Control Supply (J10)

Connect the VL+ and VL- pins on the Gold Solo Double Twitter in the manner described in the table and drawing below.

Pin	Signal	Function	Pin Positions
30	VL+	Control Supply Input	
29	VL-	Control Supply Return	
<p>1. Standard CAN (S option)            Input range: 11VDC – 95VDC            Power consumption: &lt; 2.5W (including 5 V/200 mA for encoder)</p> <p>2. EtherCAT (E option)            Input range: 11VDC – 95VDC            Power consumption: &lt; 4W (including 5 V/200 mA for encoder)</p>			

Table 4: Control Supply Pins

Connect the VL+ and VL- terminals to the power supply Control Connector.

#### To connect the VL+ and VL- to the control supply:

1. The source of the control supply must be isolated from the Mains.
2. Connect the return (common) of the control supply source to the closest earth connection near the control supply source.
3. Connect the VL+ and VL- wires to the terminals on the servo-drive as shown in Figure 11.

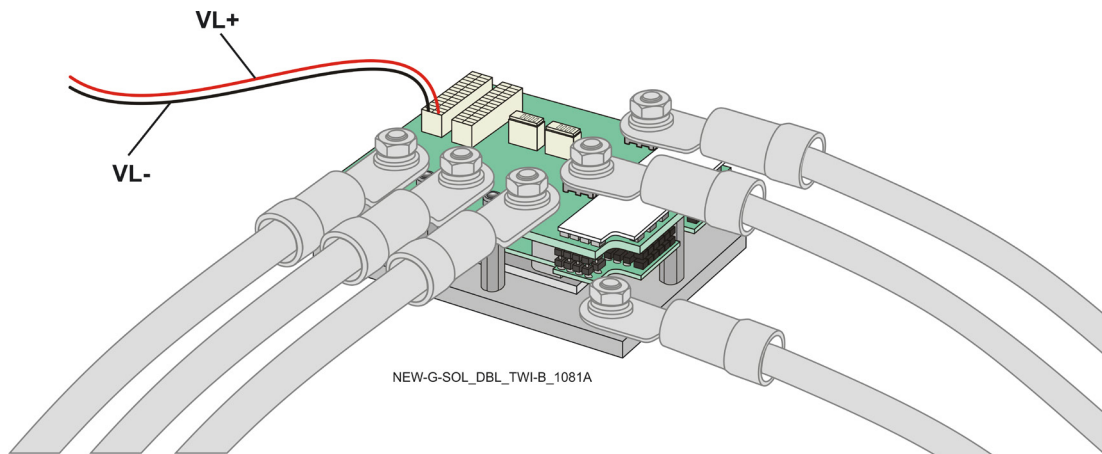

Figure 11: Connecting the Control Supply Wires

**For short distances between the drive and control, 0.5 to 1.0 m wires can be used and shielding is not required.** For longer distances than 1.0 m and/or high EMI environment, shielded and twisted wires should be used. Drain wires should be connected to Elmo COMRET.

4. Before applying power, first verify the polarity of the connection.



### 8.1.4.3. Dual Power Supply (PN G-SOLTWIDXXX/YYEESD)

Whenever dual power supply is selected by its part number, a separate supply for the Logic is required. Both the Power and Logic supplies are required to be isolated from the mains:

- A battery or main DC power source rectified from the mains, according to specification
- A control supply for the logic (VL+, VL-)

The following figure describes an ordinary power supply for Servo drives with sufficient internal capacitance and shunt regulator to manage power flow in both directions to-and-from the motor.

**Note:** The PR, COMRET, and VL- are connected internally in the Gold Solo Double Twitter.

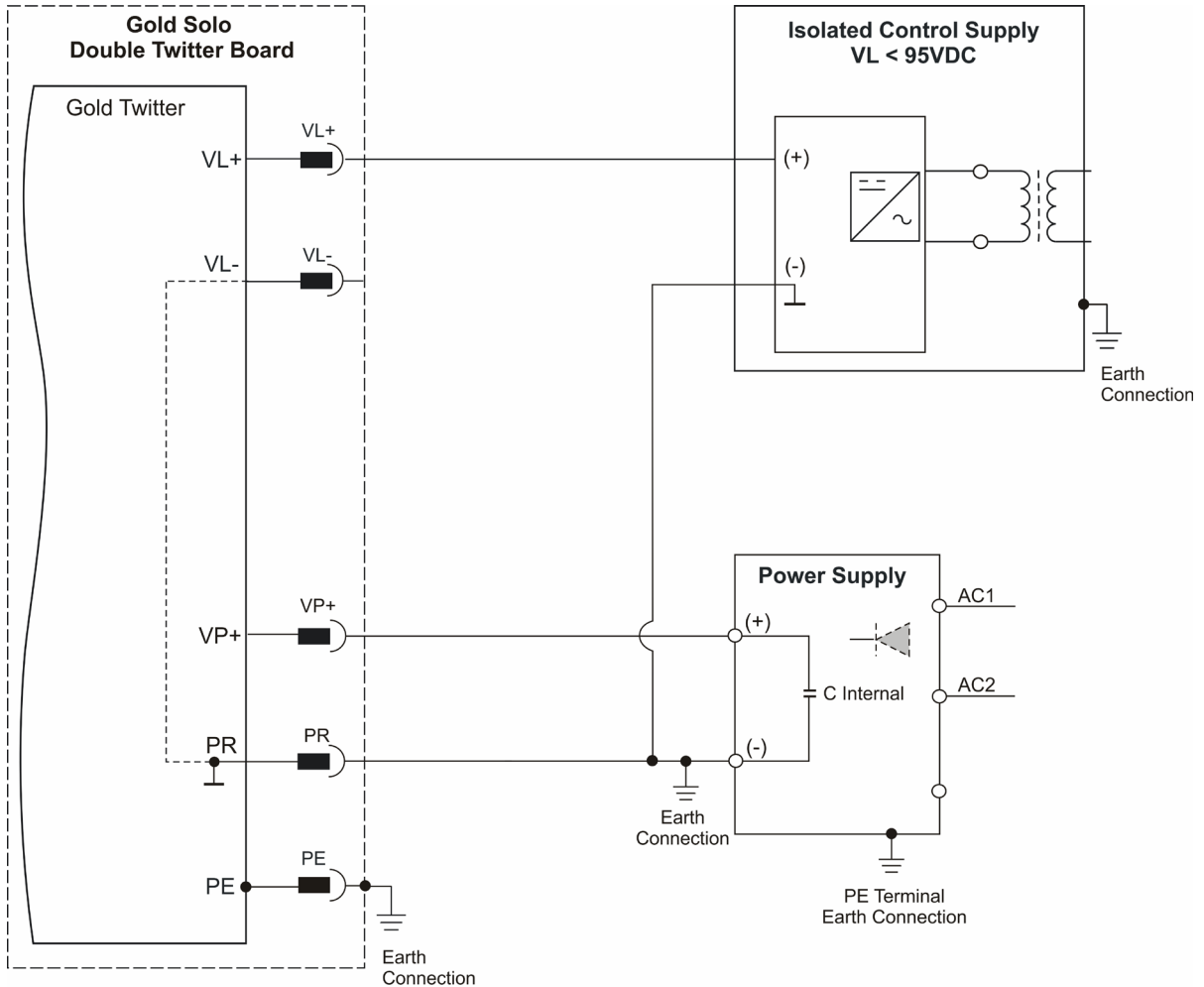

G-SOL\_DBL\_TWI-1070H

**Figure 12: Separate VP and VL Power Supplies Connection Diagram –Highly Recommended**

The (+) of the control power supply is connected to the VL+ terminal, while the (-) of the control power supply is connected directly to the (-) of the DC bus power supply. This connection avoids high current ground loops due to poor wiring (Figure 12).



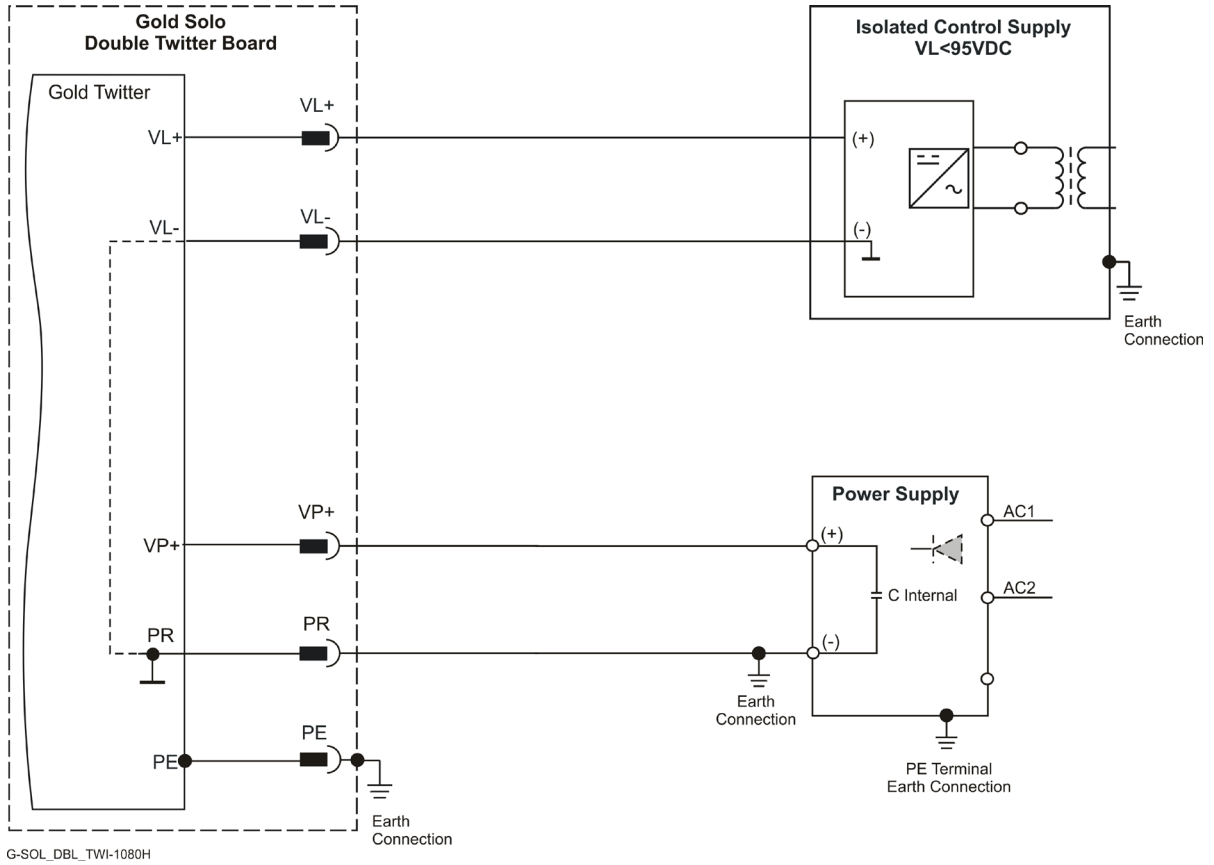

**Figure 13: Separate VP and VL Power Supplies Connection Diagram - Alternative**

The (-) of the control power supply is connected to the VL- of the Gold Solo Double Twitter (Figure 13).



### 8.1.4.4. Single Power Supply (PN G-SOLTWIDXXX/YYYYESV)

The Gold Solo Double Twitter 60V, 80V and 100V can be ordered (with V suffix) with VL+ already internally connected to the VP+.

The single power supply is selected by its part number (VL+ connected to VP+) which describes the absolute maximum VP+ and VL+ voltage which must be < 95VDC, under all conditions, to prevent VL+ supply failure.

A single power supply can be used for the main and control power in the range of 11VDC to 95VDC.

The following figure describes a single connection of main power and control:

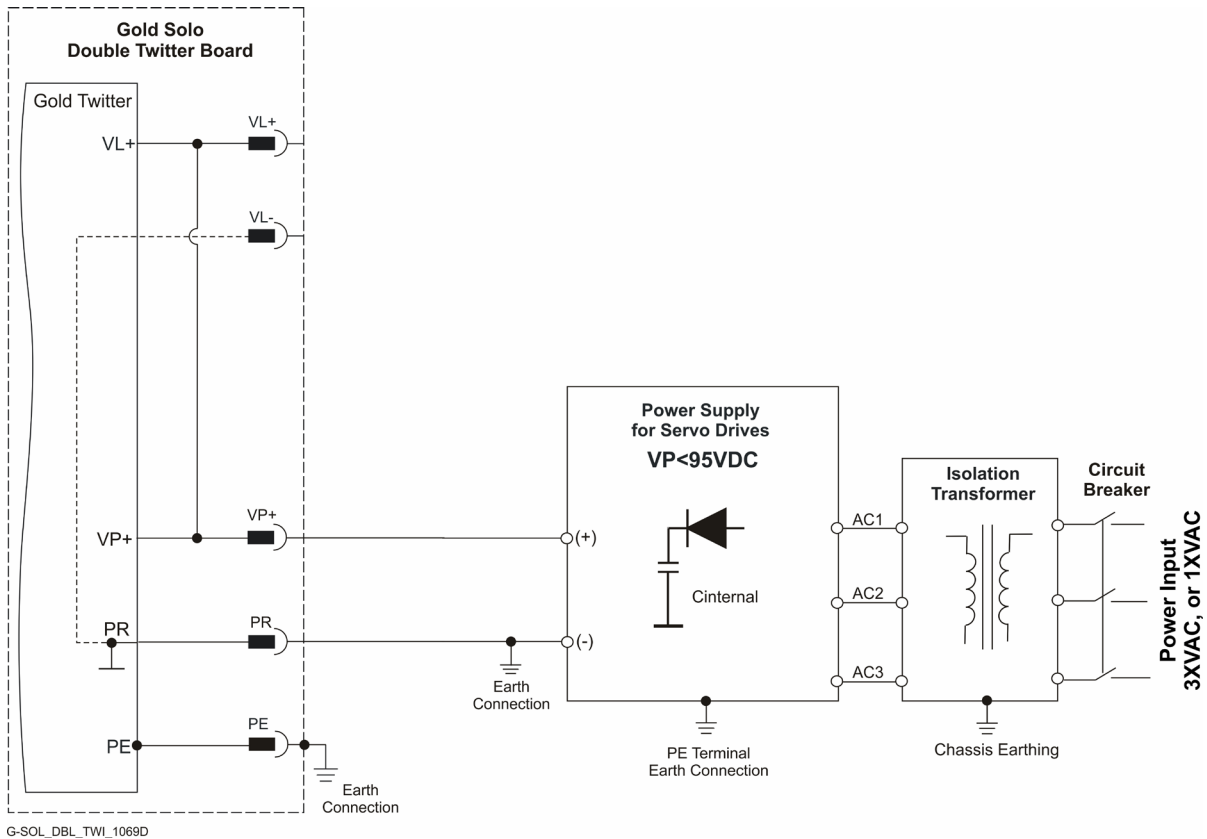

Figure 14: Single Power Supply (VP+ <95V) Connection Diagram

**Note:** This option is available for 60VDC, 80VDC and 100VDC models only.



## 8.2. Drive Status Indicator

Figure 15 shows the position of the D1 red/green dual LED, which is used for immediate indication of the Initiation and Working states. For details refer to Chapter 7 Drive Status Indicator, in the MAN-G-Panel Mounted Drives Hardware manual.

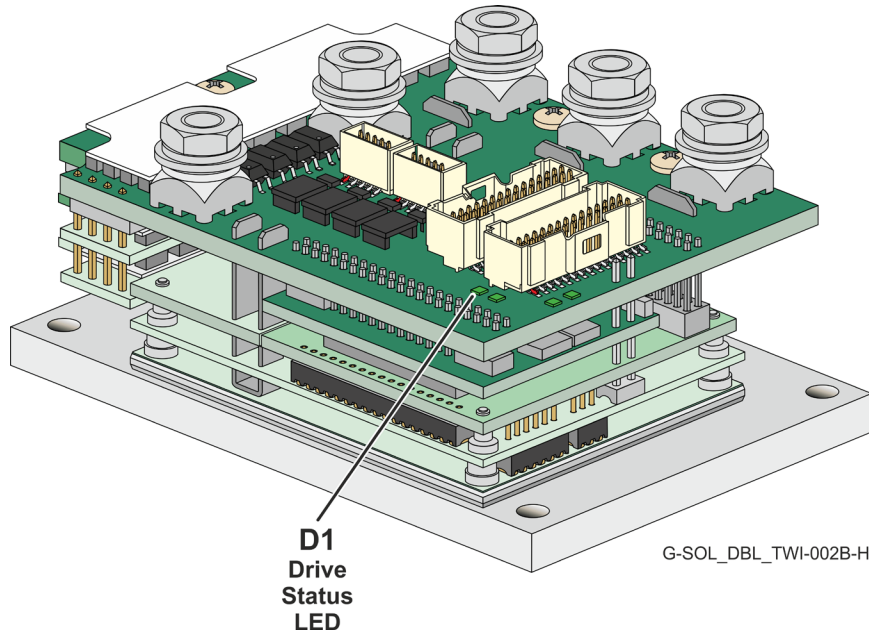

Drive Status Indicator - EtherCAT

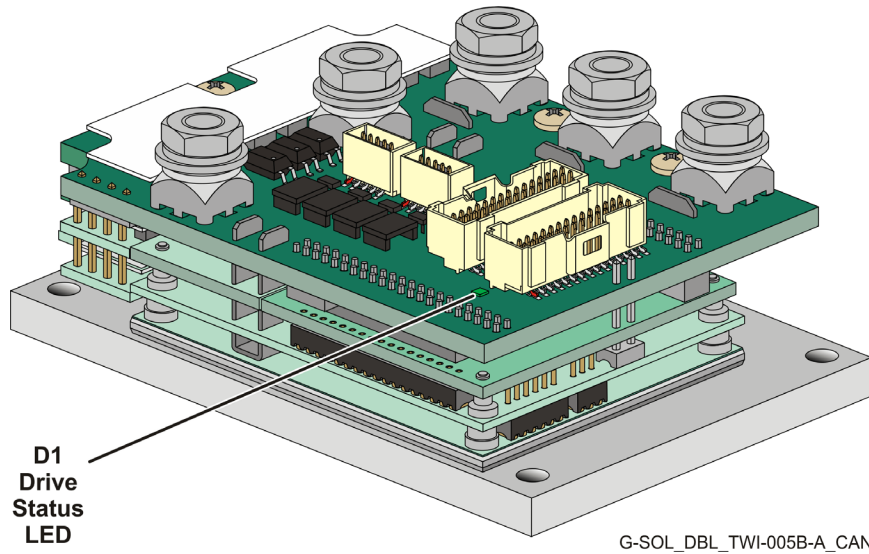

Figure 15: Drive Status Indicator - CAN

The red/green dual LED is used for immediate indication of the following states:

- **Initiation state:** In this state the LED indicates whether the drive is in the boot state (blinking red) or in the operational state (steady red).
- **Working state:** In this state the LED indicates whether the drive is in an amplifier failure state (red) or is ready to enable the motor (green).



### 8.3. J10 VL and Feedback Connector

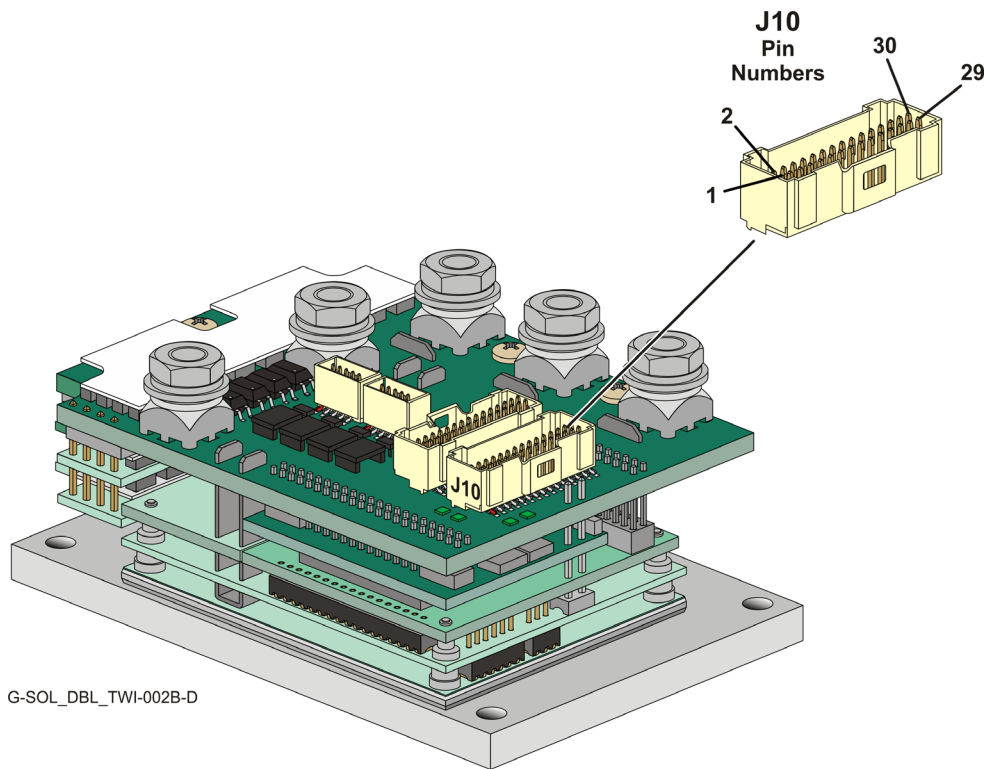

G-SOL\_DBL\_TWI-002B-D

J10 VL & Feedback Connector

**Feedback A/B/C, Digital Halls – see Section 9.2 in the manual: MAN-G-Board Level Modules Hardware Manual.**

The following table describes the J10 VL and Feedback connections to the 2 x 15 pins female connector.

Pin J10	Signal	Function
1	PortA_ENC_A+ / ABS_CLK+	Channel A+ / Abs encoder clock +
2	PortB_ENC_A-	Port B Channel A-
3	PortA_ENC_A- / ABS_CLK-	Channel A- / Abs encoder clock -
4	PortB_ENC_A+	Port B Channel A+
5	PortA_ENC_B+ / ABS_DATA+	Channel B+ / Abs encoder data +
6	PortB_ENC_B-	Port B Channel B-
7	PortA_ENC_B- / ABS_DATA-	Channel B- / Abs encoder data -
8	PortB_ENC_B+	Port B Channel B+
9	PortA_ENC_INDEX+	Index+
10	PortB_ENC_INDEX-	Port B Index-



Pin J10	Signal	Function
11	PortA_ENC_INDEX-	Index-
12	PortB_ENC_INDEX+	Port B Index+
13	HA	Hall sensor A
14	PortC_ENCO_A-	Buffered Channel A- output / Pulse- / PWM-
15	HB	Hall sensor B
16	PortC_ENCO_A+	Buffered Channel A+ output/Pulse+/PWM+
17	HC	Hall sensor C
18	PortC_ENCO_B-	Buffered Channel B- output / Dir-
19	+5V	Encoder +5V supply with a total allowable maximum consumption of 200mA using Pins 19 or 26.
20	PortC_ENCO_B+	Buffered Channel B+ output / Dir+
21	COMRET	Common return
22	PortC_ENCO_Index-	Buffered Channel INDEX- output
23	COMRET	Common return
24	PortC_ENCO_Index+	Buffered Channel INDEX+ output
25	COMRET	Common return
26	+5V	Encoder +5V supply with a total allowable maximum consumption of 200mA using Pins 19 or 26.
27	COMRET	Common return
28	COMRET	Common return
29	VL-	Control 24V supply return
30	VL+	Control 24V supply

**Table 5: Connector J10 – VL & Feedback**

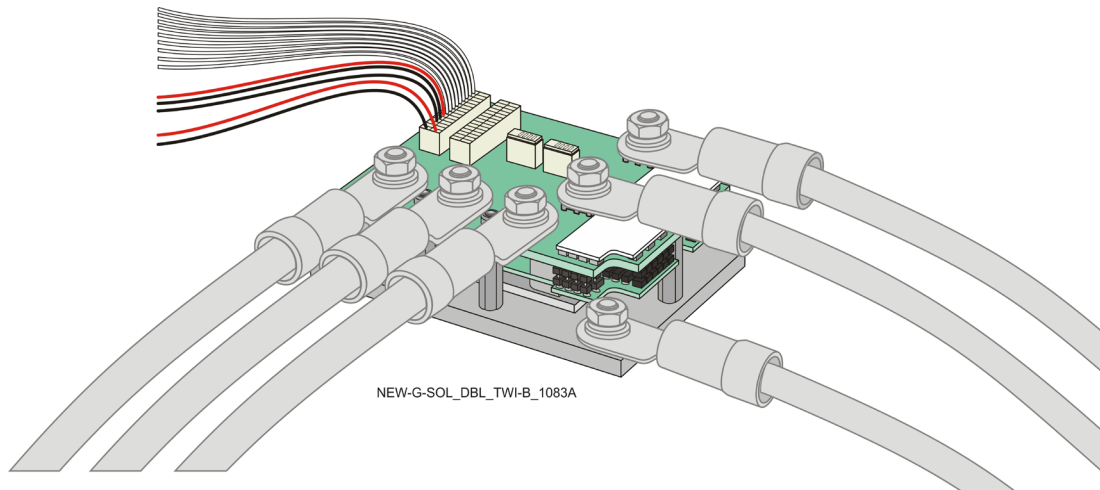

**Figure 16: Connecting the Feedback Wires**

**For short distances between the drive and control, 0.5 to 1.0 m wires can be used and shielding is not required.** For longer distances than 1.0 m and/or high EMI environment, shielded and twisted wires should be used. Drain wires should be connected to Elmo COMRET.



### 8.3.1. Port A

Refer to section 10.3 in the MAN-G-Board Level Modules Hardware Manual for further details of the Port A connections.

#### 8.3.1.1. Incremental Encoder

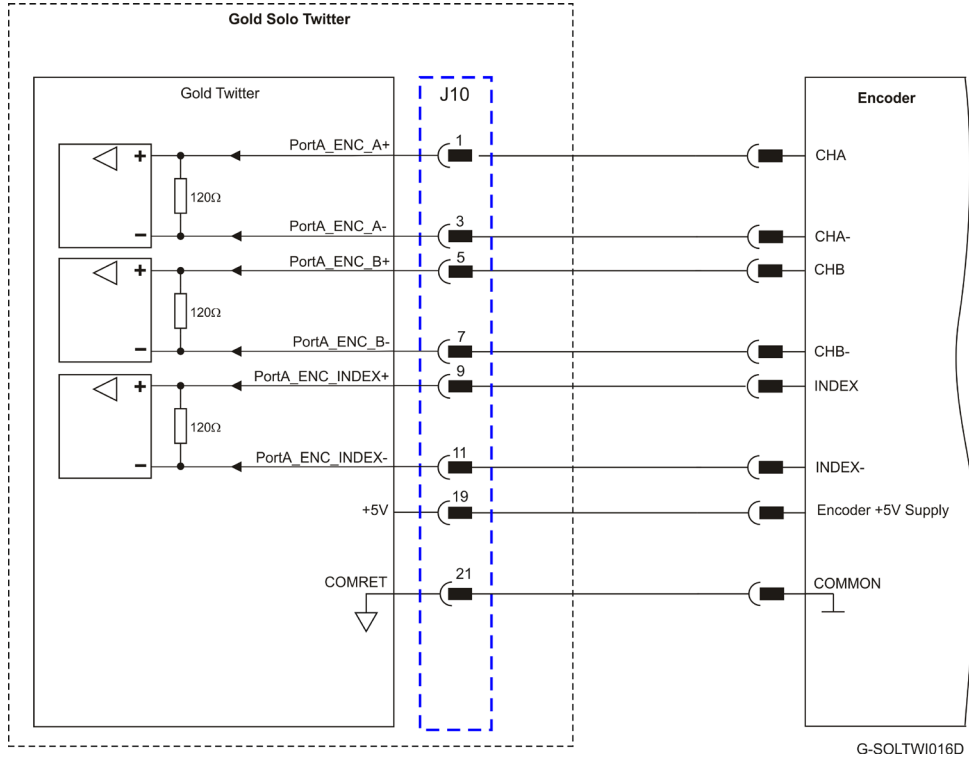

Figure 17: Port A Incremental Encoder Input – Recommended Connection Diagram

For short distances between the drive and control, 0.5 to 1.0 m wires can be used and shielding is not required. For longer distances than 1.0 m and/or high EMI environment, shielded and twisted wires should be used. Drain wires should be connected to Elmo COMRET.



### 8.3.1.2. Absolute Serial Encoder

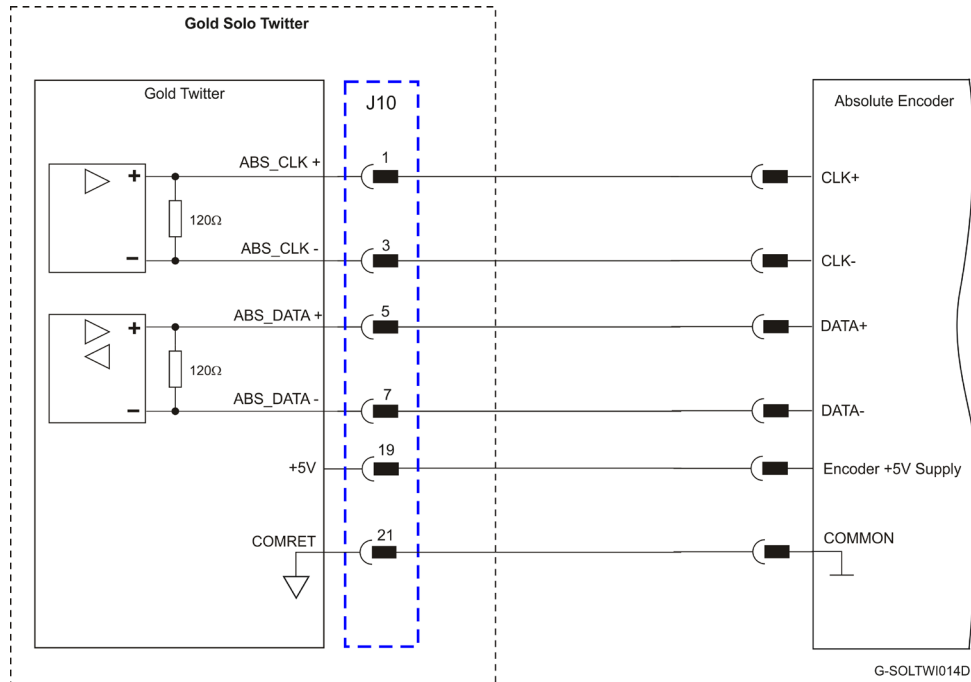

Figure 18: Absolute Serial Encoder – Recommended Connection Diagram for Sensors Supporting Data/Clock (e.g., Biss / SSI / EnDAT, etc.)

For short distances between the drive and control, 0.5 to 1.0 m wires can be used and shielding is not required. For longer distances than 1.0 m and/or high EMI environment, shielded and twisted wires should be used. Drain wires should be connected to Elmo COMRET.

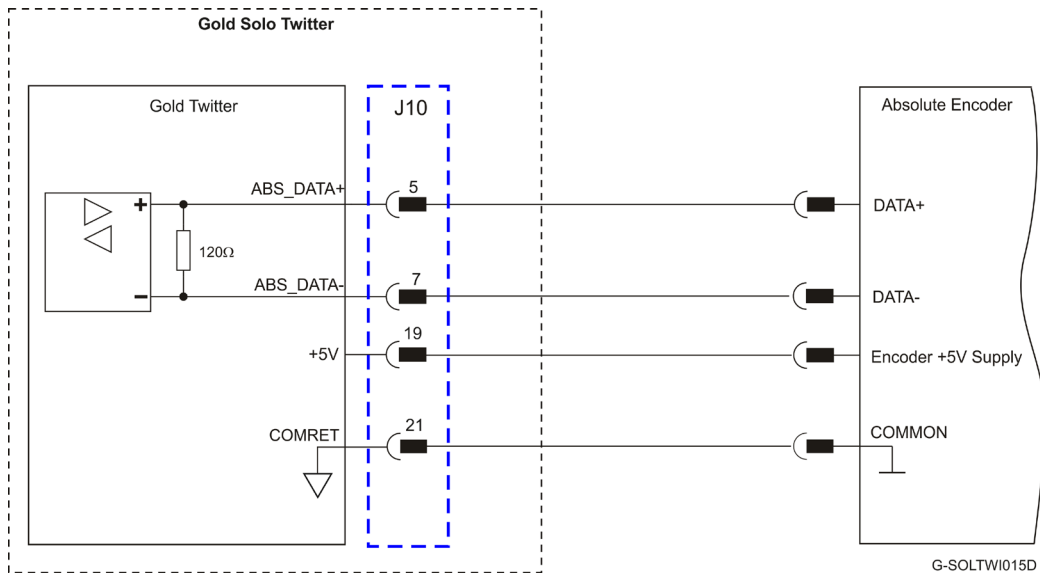

Figure 19: Absolute Serial Encoder – Recommended Connection Diagram for Sensors Supporting Data Line Only (NRZ types, e.g., Panasonic / Mitutoyo / etc.)

For short distances between the drive and control, 0.5 to 1.0 m wires can be used and shielding is not required. For longer distances than 1.0 m and/or high EMI environment, shielded and twisted wires should be used. Drain wires should be connected to Elmo COMRET.





### 8.3.1.3. Hiperface

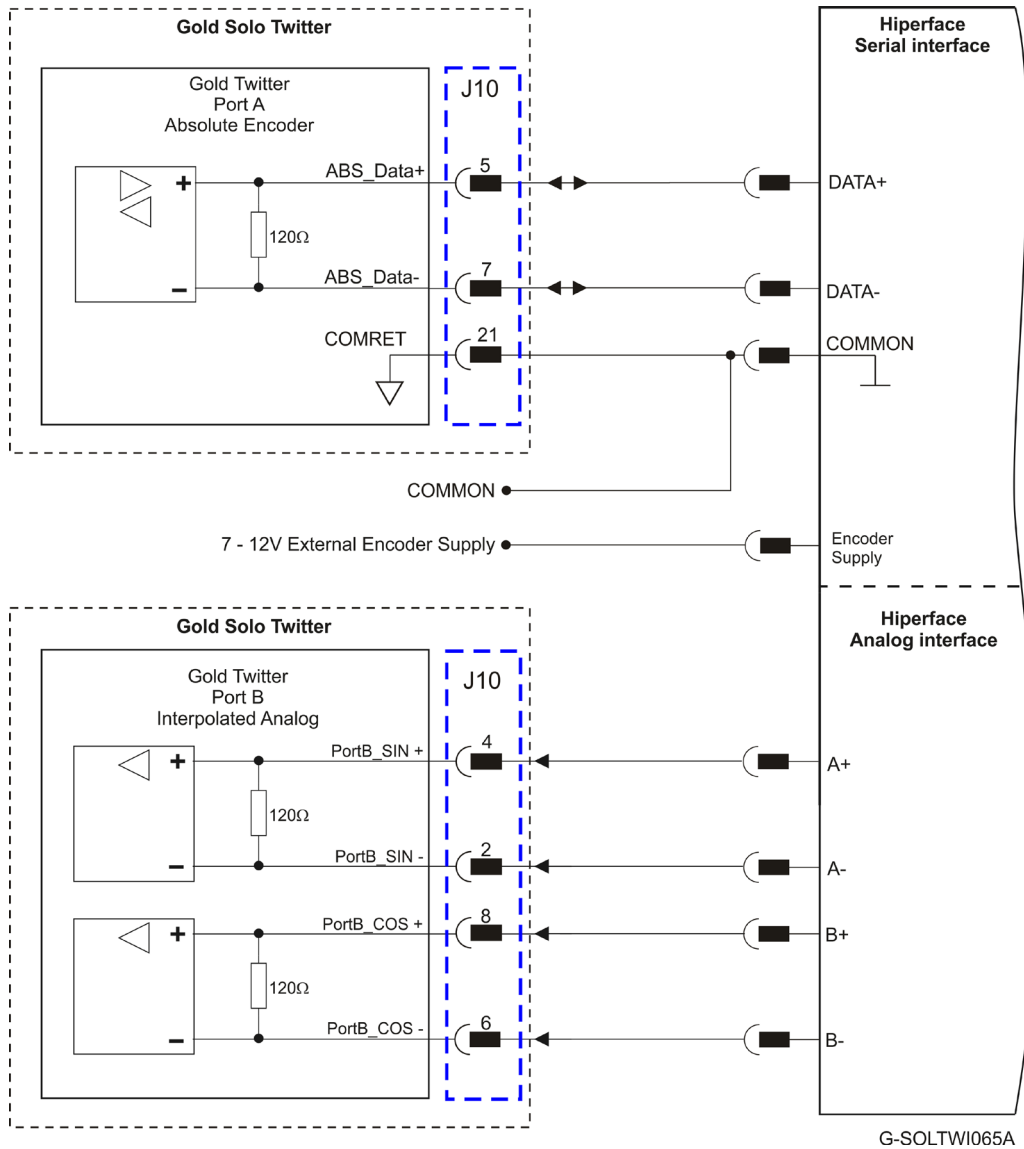

Figure 20: Absolute Serial Encoder – Recommended Connection Diagram for Stegmann Hiperface

**Note:** When the Hiperface protocol is used, the RS-232 connection is not available.

For short distances between the drive and control, 0.5 to 1.0 m wires can be used and shielding is not required. For longer distances than 1.0 m and/or high EMI environment, shielded and twisted wires should be used. Drain wires should be connected to Elmo COMRET.



### 8.3.1.4. Hall Sensors

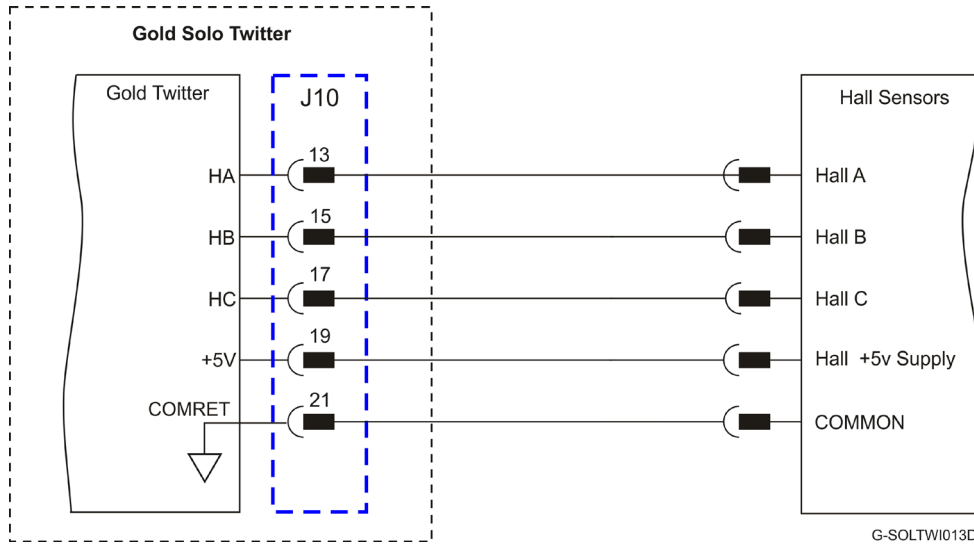

Figure 21: Hall Sensors Connection Diagram

For short distances between the drive and control, 0.5 to 1.0 m wires can be used and shielding is not required. For longer distances than 1.0 m and/or high EMI environment, shielded and twisted wires should be used. Drain wires should be connected to Elmo COMRET.



### 8.3.2. Port B

Refer to section 10.4 in the MAN-G-Board Level Modules Hardware Manual for further details of the Port B connections.

#### 8.3.2.1. Incremental Encoder

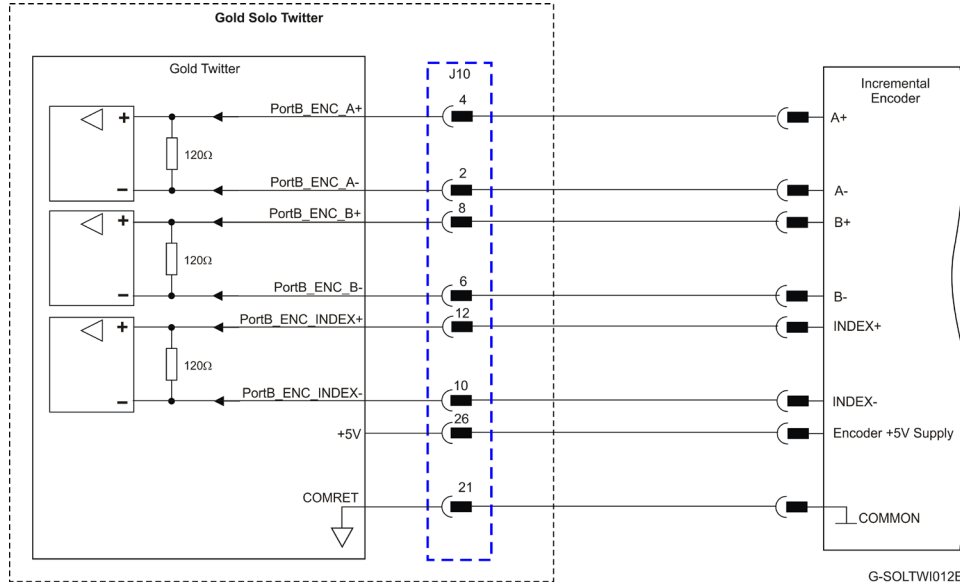

Figure 22: Port B Incremental Encoder Input – Recommended Connection Diagram

For short distances between the drive and control, 0.5 to 1.0 m wires can be used and shielding is not required. For longer distances than 1.0 m and/or high EMI environment, shielded and twisted wires should be used. Drain wires should be connected to Elmo COMRET.

#### 8.3.2.2. Interpolated Analog Encoder

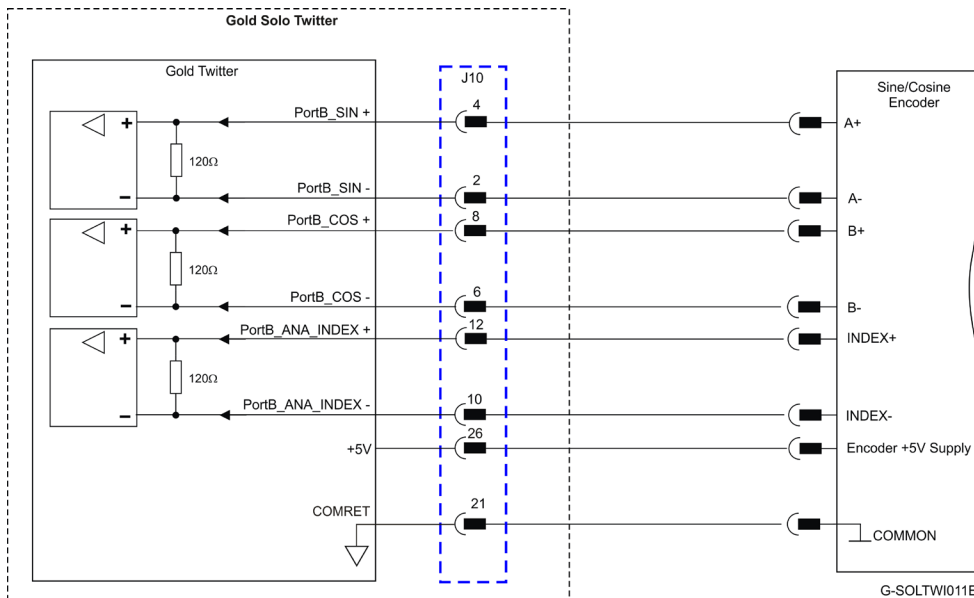

Figure 23: Port B - Interpolated Analog Encoder Connection Diagram

For short distances between the drive and control, 0.5 to 1.0 m wires can be used and shielding is not required. For longer distances than 1.0 m and/or high EMI environment, shielded and twisted wires should be used. Drain wires should be connected to Elmo COMRET.



### 8.3.2.3. Resolver

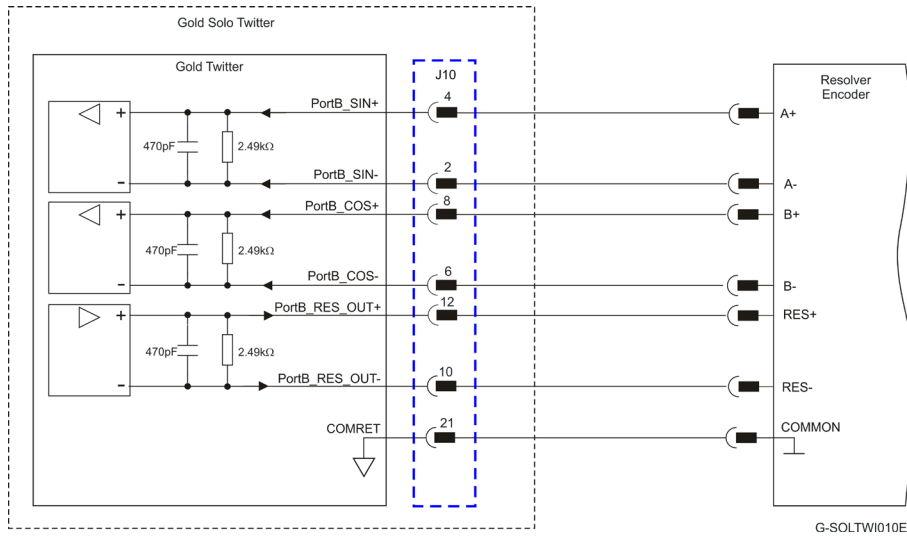

Figure 24: Port B – Resolver Connection Diagram

For short distances between the drive and control, 0.5 to 1.0 m wires can be used and shielding is not required. For longer distances than 1.0 m and/or high EMI environment, shielded and twisted wires should be used. Drain wires should be connected to Elmo COMRET.

### 8.3.3. Port C – Emulated Encoder Output (J10)

See Section 10.5 in the manual: MAN-G-Board Level Modules Hardware Manual for further details of Port C.

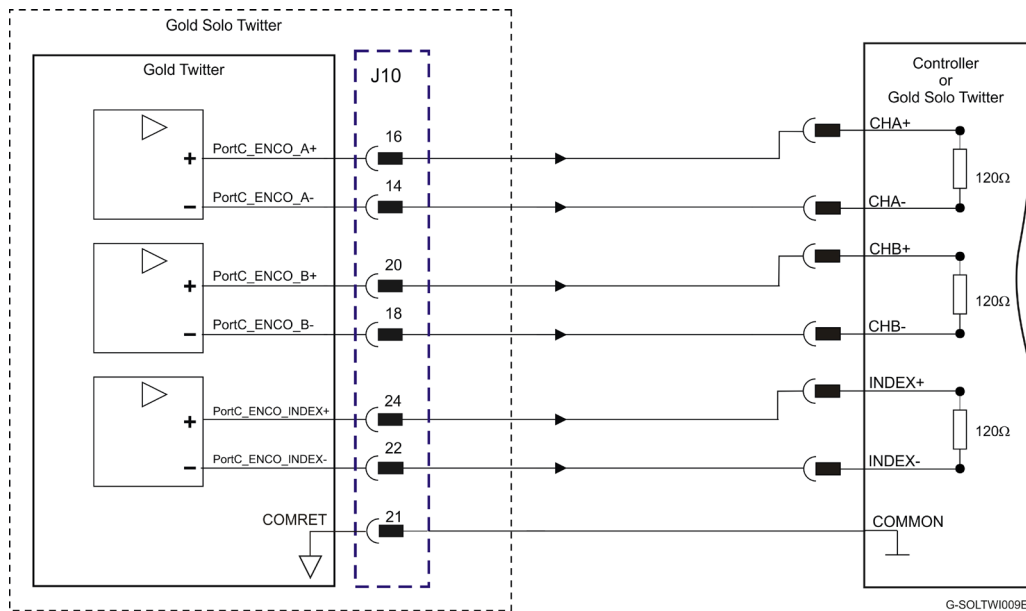
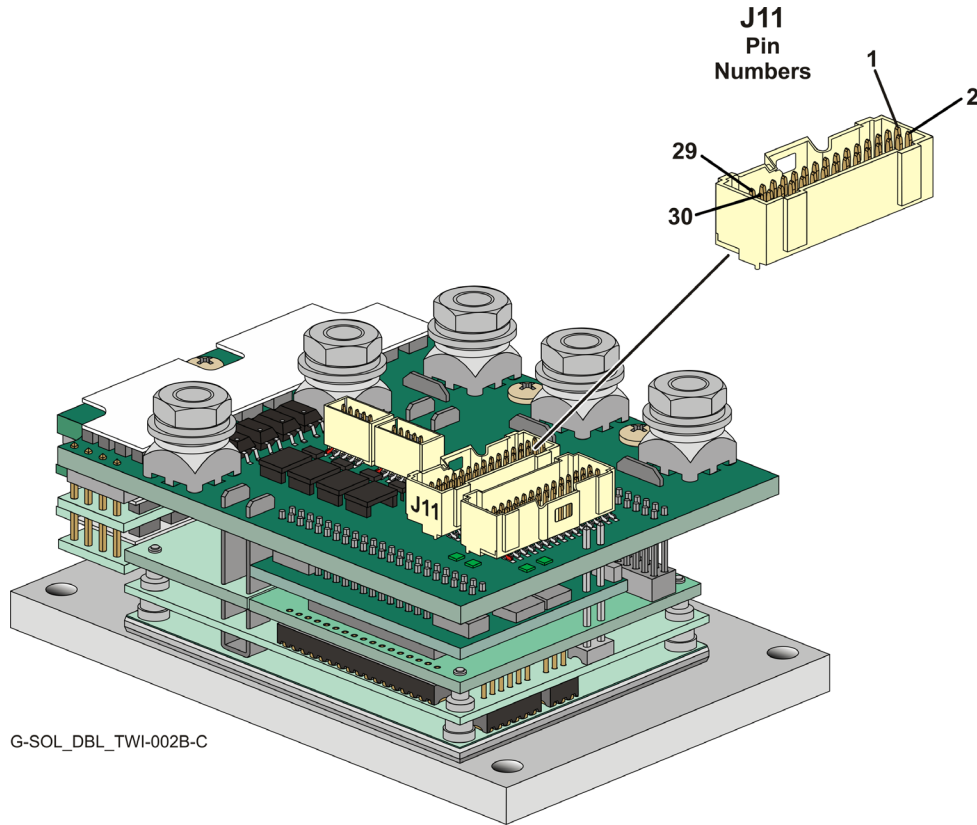

Figure 25: Emulated Encoder Differential Output – Recommended Connection Diagram

For short distances between the drive and control, 0.5 to 1.0 m wires can be used and shielding is not required. For longer distances than 1.0 m and/or high EMI environment, shielded and twisted wires should be used. Drain wires should be connected to Elmo COMRET.



## 8.4. J11 I/O and Communication Connector



G-SOL\_DBL\_TWI-002B-C

**J11 I/O and Communication Connector**

Pin J11	Signal	Function
1	IN1	High speed programmable digital input 1 (opto isolated from control COMRET)
2	IN2	High speed programmable digital input 2 (opto isolated from control COMRET)
3	IN3	High speed programmable digital input 3 (opto isolated from control COMRET)
4	IN4	High speed programmable digital input 4 (opto isolated from control COMRET)
5	IN5	High speed programmable digital input 5 (opto isolated from control COMRET)
6	IN6	High speed programmable digital input 6 (opto isolated from control COMRET)
7	INRET	D <sub>in</sub> return
8	INRET	D <sub>in</sub> return



Pin J11	Signal	Function
9	OUT1	Programmable output 1 (opto isolated from control COMRET)
10	OUT2	Programmable output 2 (opto isolated from control COMRET)
11	OUT3	Programmable output 3 (opto isolated from control COMRET)
12	OUT4	Programmable output 4 (opto isolated from control COMRET)
13	OUTRET	D <sub>out</sub> return
14	OUTRET	D <sub>out</sub> return
15	STO1	STO 1 input opto isolated from control COMRET
16	STO2	STO 2 input opto isolated from control COMRET
17	STO_RET	STO signal return. The two digital STO inputs are optically isolated from the other parts of the drive, and share one return line.
18	STO_RET	STO signal return. The two digital STO inputs are optically isolated from the other parts of the drive, and share one return line.
19	COMRET	Common return
20	GPIO5 ANALOG IN	GPIO5 Analog input
21	ANALOG1+	Analog input 1
22	ANALOG1-	Analog input 1 complement
23	COMRET	Common return
24	COMRET	Common return
25	RS-232_TX	RS-232 Transmit
26	RS-232_RX	RS-232 Receive
27	USB_VBUS	USB VBUS detector (Only for EtherCAT version)
28	COMRET	Common return
29	USB D+	USB _P line (Only for EtherCAT version)
30	USB D-	USB _N line (Only for EtherCAT version)

**Table 6: I/O, STO, Analog, RS-232, and USB Connector**

**STO (safety):** For full details on STO, see Chapter 9 in the in the MAN-G-Board Level Modules Hardware manual for full details.

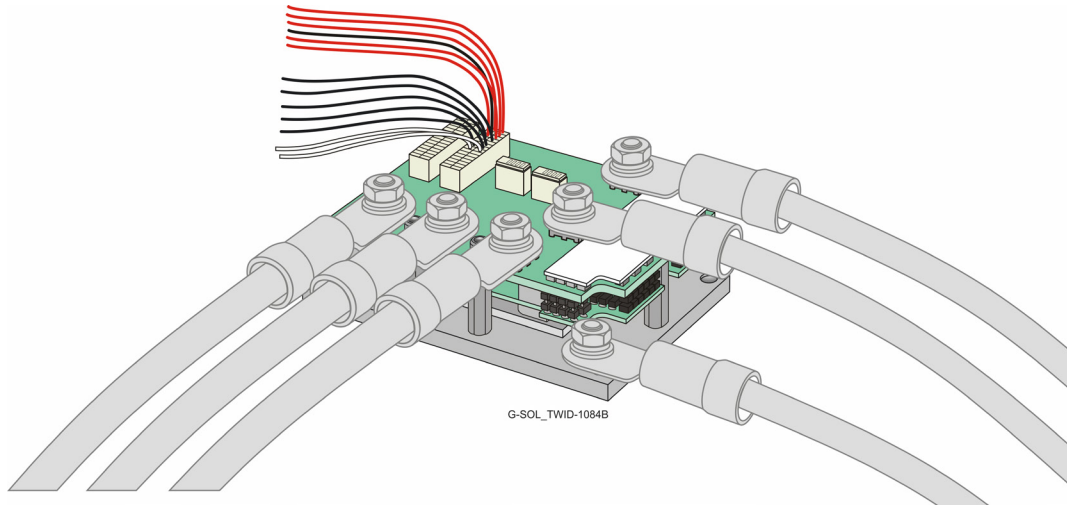

**Figure 26: Connecting the USB, RS232, and Analog Input Wires**

**For USB, RS232, and Analog Input Wires**

**For short distances between the drive and control, 0.5 to 1.0 m wires can be used and shielding is not required.** For longer distances than 1.0 m and/or high EMI environment, shielded and twisted wires should be used. Drain wires should be connected to Elmo COMRET.

**For Digital Inputs/Outputs, STO**

Wires can be always used, no need for twisting, no need for shielding.



## 8.4.1. Digital Inputs

### 8.4.1.1. Source PLC Voltage Level Digital Input

Feature	Details
Standard	Isolated PLC source Conforming to IEC 61131-2
Input current	$I_{in} = (V_{in} - 7.4) / 4.99 \text{ Kohm}$ $I_{in} = 920 \text{ uA @ } V_{in} = 12 \text{ V}$ $I_{in} = 4.5 \text{ mA @ } V_{in} = 30 \text{ V}$
High-level input voltage	$12 \text{ V} < V_{in} < 30 \text{ V}$
Low-level input voltage	$0 \text{ V} < V_{in} < 7 \text{ V}$
Minimum pulse width	$> 250 \text{ } \mu\text{sec}$
Execution time (all inputs): the time from application of voltage on input until execution is complete	$0 < T < 250 \text{ } \mu\text{sec}$
High-speed inputs – 1–6 minimum pulse width, in high-speed mode	$T > 5 \text{ } \mu\text{sec}$ if the input functionality is set to latch/capture (index/strobe). <b>Notes:</b> <ul style="list-style-type: none"> <li>Home mode is high-speed mode and can be used for fast capture and precise homing.</li> <li>Highest speed is achieved when turning on optocouplers.</li> </ul>
Capture with differential input Port A, Port B Index	$T > 0.1 \text{ } \mu\text{sec}$ if the differential input functionality is set to touch probe/capture (index/strobe).

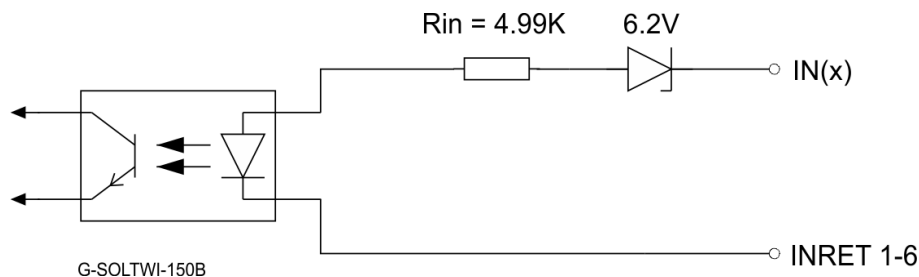

Figure 27: Digital Input PLC Source Schematic





The following are the connection diagram of Digital inputs:

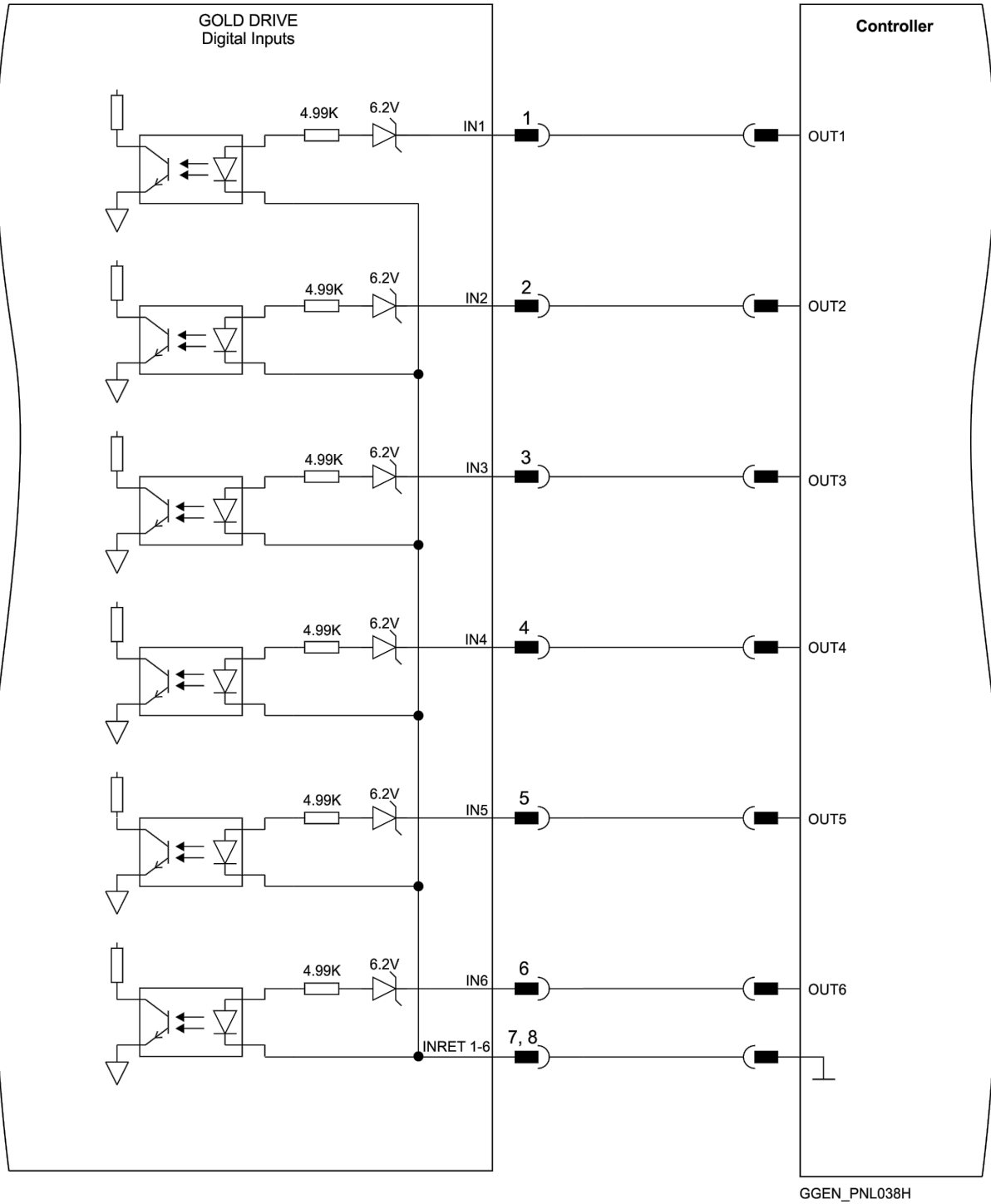

Figure 28: Digital Input Connection Diagram Example – Source PLC Option



### 8.4.1.2. Sink PLC Voltage Level Digital Input

Feature	Details
Type of input	Isolated PLC Sink
Input current	$I_{in} = (V_{in} - 7.4) / 4.99K\Omega$ $I_{in} = 920 \mu A @ V_{in} = 12 V$ $I_{in} = 4.5 mA @ V_{in} = 30 V$
High-level input voltage	$12 V < V_{in} < 30 V$
Low-level input voltage	$0 V < V_{in} < 7 V$
Minimum pulse width	$> 250 \mu sec$
Execution time (all inputs): the time from application of voltage on input until execution is complete	$0 < T < 250 \mu sec$
High-speed inputs – 1–6 minimum pulse width, in high-speed mode	$T > 5 \mu sec$ if the input functionality is set to latch/capture (index/strobe). <b>Notes:</b> <ul style="list-style-type: none"> <li>Home mode is high-speed mode and can be used for fast capture and precise homing.</li> <li>Highest speed is achieved when turning on optocouplers.</li> </ul>
Capture with differential input Port A, Port B Index	$T > 0.1 \mu sec$ if the differential input functionality is set to touch probe/capture (index/strobe).

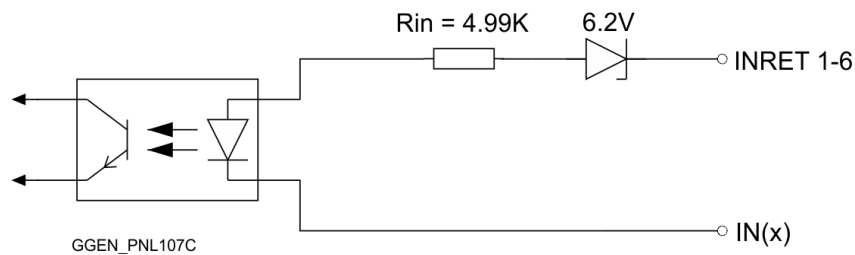
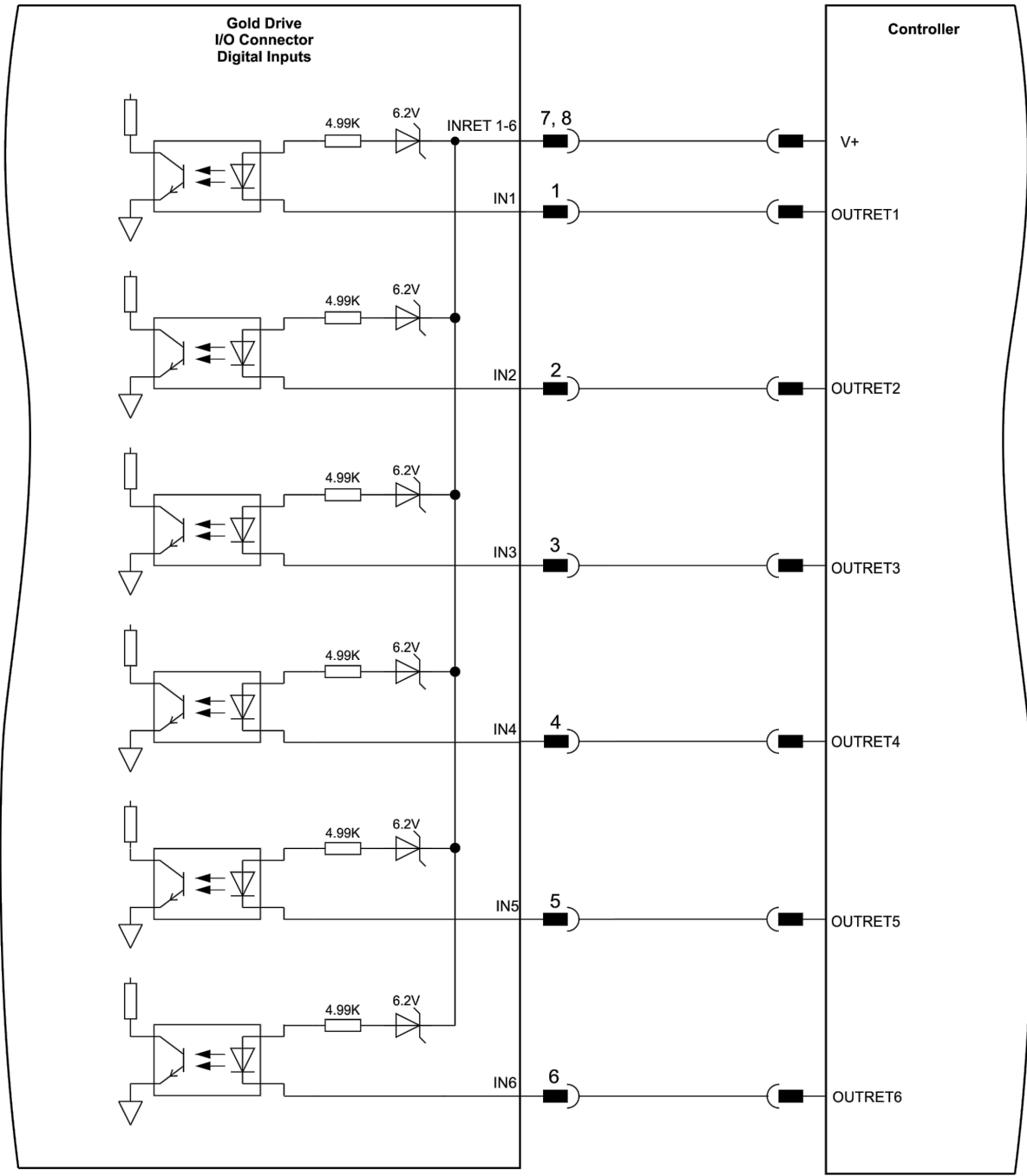

Figure 29: Digital Input Sink PLC Schematic



GGEN\_PNL039H

Figure 30: Digital Input Sink Mode Example – PLC voltage level Connection Diagram



### 8.4.1.3. Source 5V Logic Level Digital Input

Feature	Details
Type of input	Optically isolated
Input current for all inputs	$I_{in} = 3.8 \text{ mA @ } V_{in} = 5 \text{ V}$
High-level input voltage	$3.0 \text{ V} < V_{in} < 10 \text{ V}$ , 5 V typical
Low-level input voltage	$0 \text{ V} < V_{in} < 0.8 \text{ V}$
Minimum pulse width	$> 250 \text{ } \mu\text{sec}$
Execution time (all inputs): the time from application of voltage on input until execution is complete	$0 < T < 250 \text{ } \mu\text{sec}$
High-speed inputs – 1–6 minimum pulse width, in high-speed mode	$T > 5 \text{ } \mu\text{sec}$ if the input functionality is set to latch/capture (index/strobe). <b>Notes:</b> Home mode is high-speed mode and can be used for fast capture and precise homing. Highest speed is achieved when turning on optocouplers.

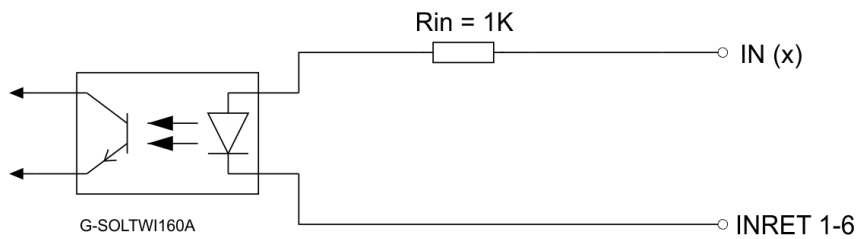

Figure 31: Digital Input 5V Logic Schematic

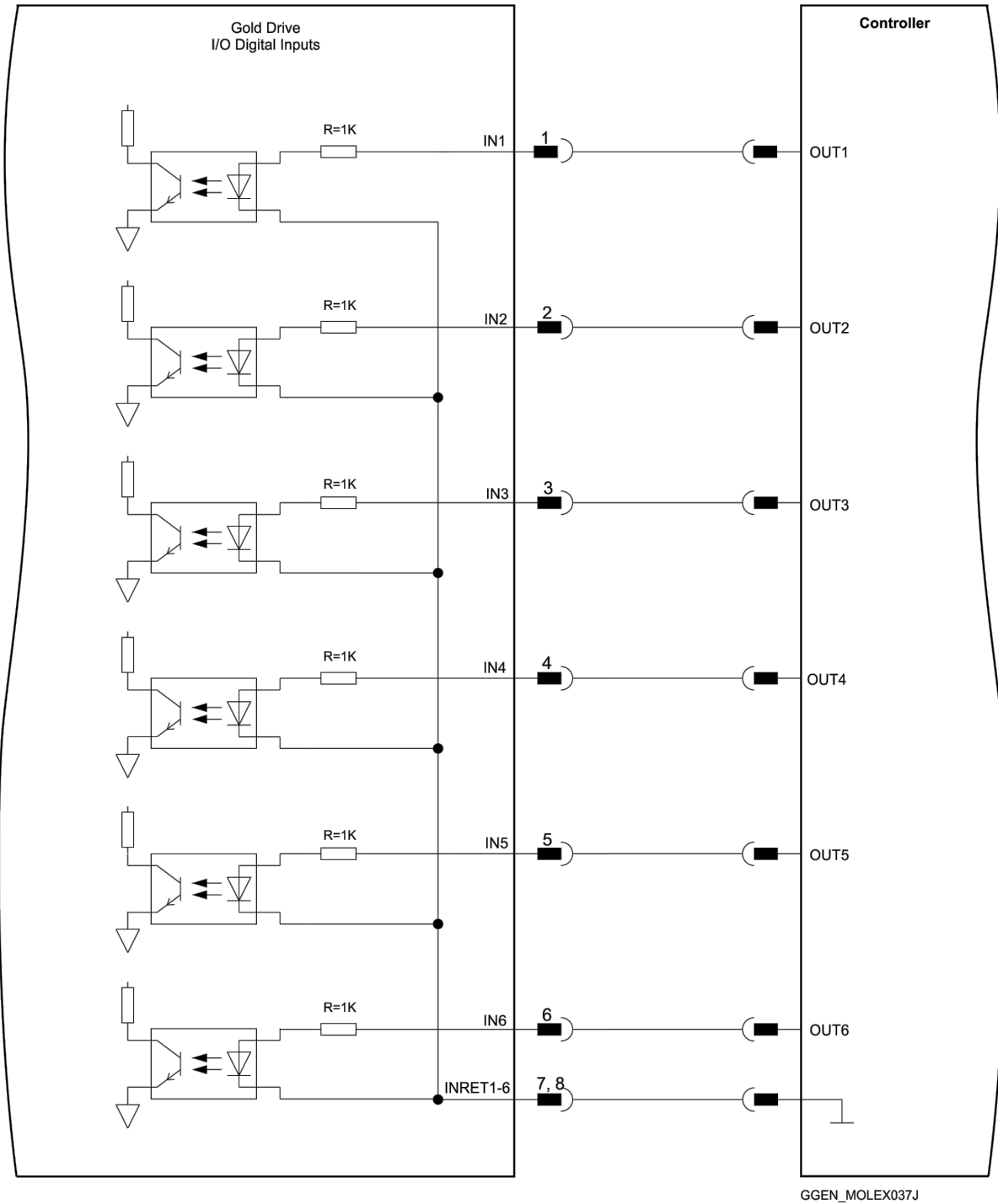

Figure 32: Digital Input Source 5V Logic Mode Connection Diagram



## 8.4.2. Digital Outputs

### 8.4.2.1. Source PLC Voltage Level Digital Output

Feature	Details
Type of output	Optically isolated PLC source
Supply output (VDD)	12 V to 30 V (typically 24 V)
Max. output current $I_{out (max)} (V_{out} = High)$	$I_{out (max)} \leq 30 \text{ mA}$
Collector Emitter saturation voltage	1 V
$T_{on}$ (Time from low to high) If $V_{dd} = 24V$	$< 15 \mu\text{sec}$
$T_{off}$ (Time from high to Low)	$< 250 \mu\text{sec}$
$R_L$	The external $R_L$ must be selected to limit output current to no more than 30 mA. $R_L = \frac{VDD - 1}{I_{out (max)}}$
Executable time	$0 < T < 250 \mu\text{sec}$

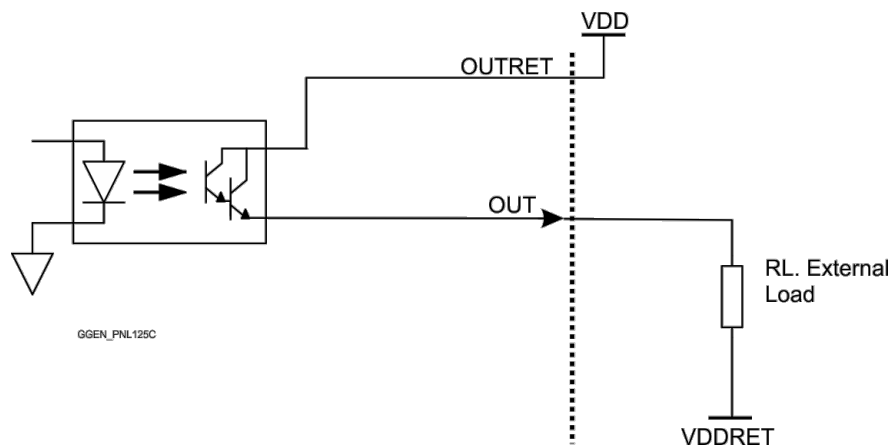

Figure 33: Digital Photodarlington Output Schematic – Source Mode PLC Level

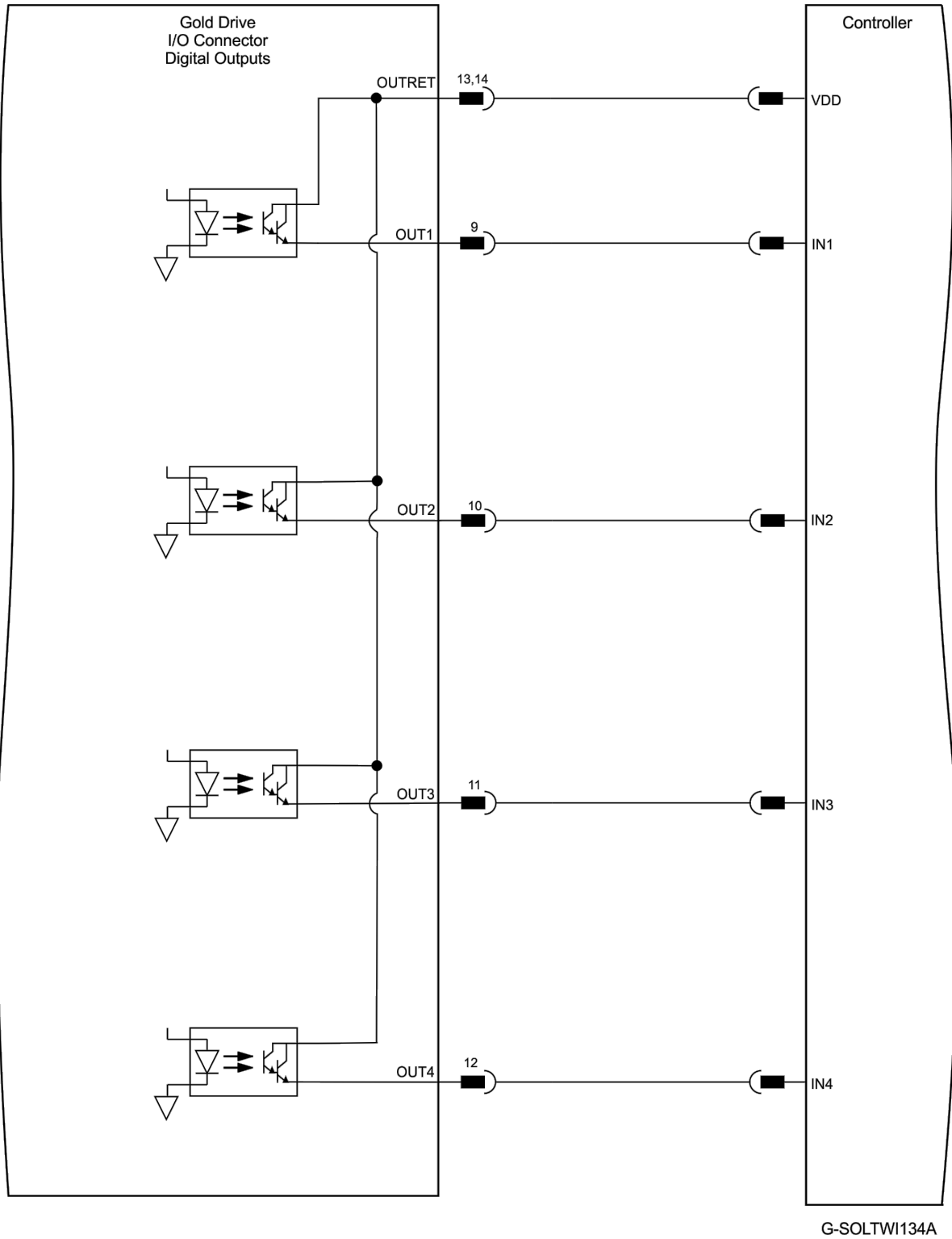
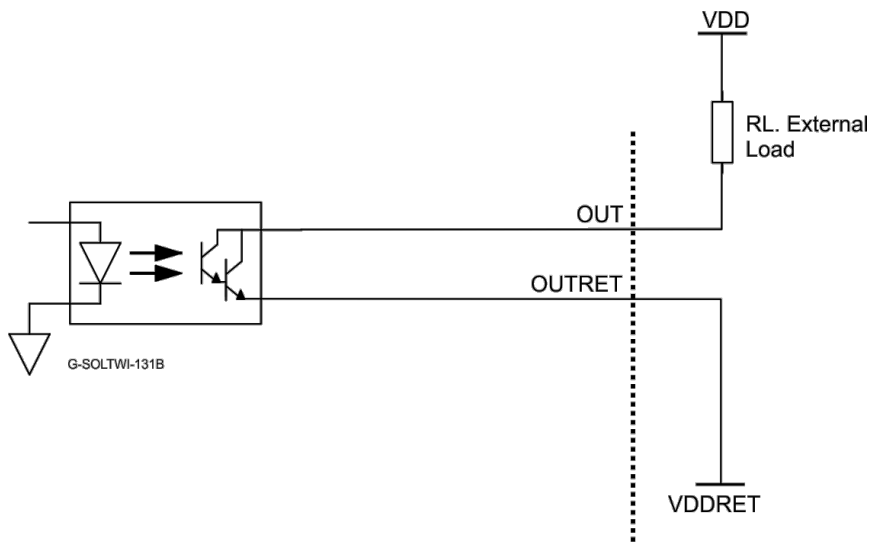

Figure 34: Digital Output Connection Diagram Example – Source PLC Option

**8.4.2.2. Sink PLC Voltage Level Digital Output**

Feature	Details
Type of output	Optically isolated PLC Sink
Supply output (VDD)	12 V to 30 V (Typically 24 V)
Max. output current $I_{out} (max) (V_{out} = Low)$	$I_{out} (max) \leq 30 \text{ mA}$
Collector Emitter saturation voltage	1 V
$T_{on}$ (Time from low to high) If $V_{dd} = 24V$	$< 15 \mu\text{sec}$
$T_{off}$ (Time from high to Low)	$< 300 \mu\text{sec}$
$R_L$	The external $R_L$ must be selected to limit output current to no more than 30 mA. $R_L = \frac{VDD - 1}{I_{out} (max)}$
Executable time	$0 < T < 250 \mu\text{sec}$

**Figure 35: Digital Photodarlington Output Schematic for Sink – PLC level**



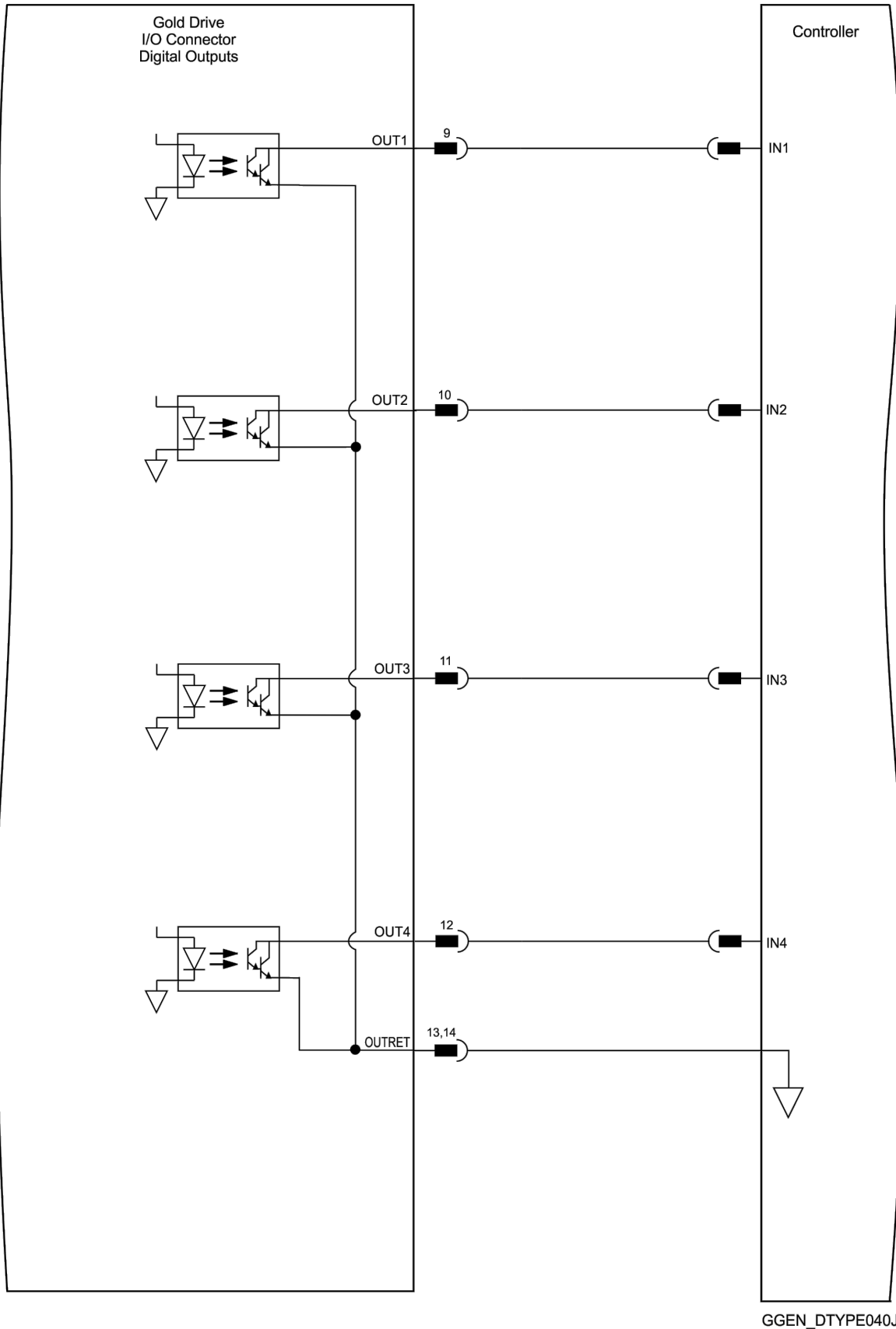

Figure 36: Digital Output Connection Diagram Example – Sink PLC Option



### 8.4.2.3. Digital Outputs Source 5V Logic Mode

Feature	Details
Type of output	Optically isolated 5V Logic source
Supply output (VDD)	< 30 V (Typically 5 V)
Max. output current $I_{out} (max) (V_{out} = High)$	$I_{out} (max) \leq 30 \text{ mA}$
Collector Emitter saturation voltage	1 V
$T_{on}$ (Time from low to high) If $V_{dd} = 5V$	< 10 $\mu$ sec
$T_{off}$ (Time from high to Low)	< 100 $\mu$ sec
$R_L$	The external $R_L$ must be selected to limit output current to no more than 30 mA. $R_L = \frac{VDD - 1}{I_{out} (max)}$
Executable time	$0 < T < 250 \mu\text{sec}$

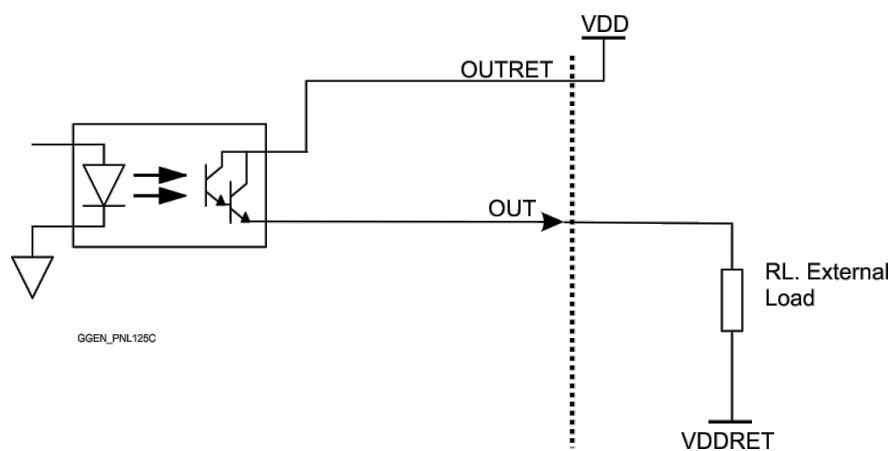
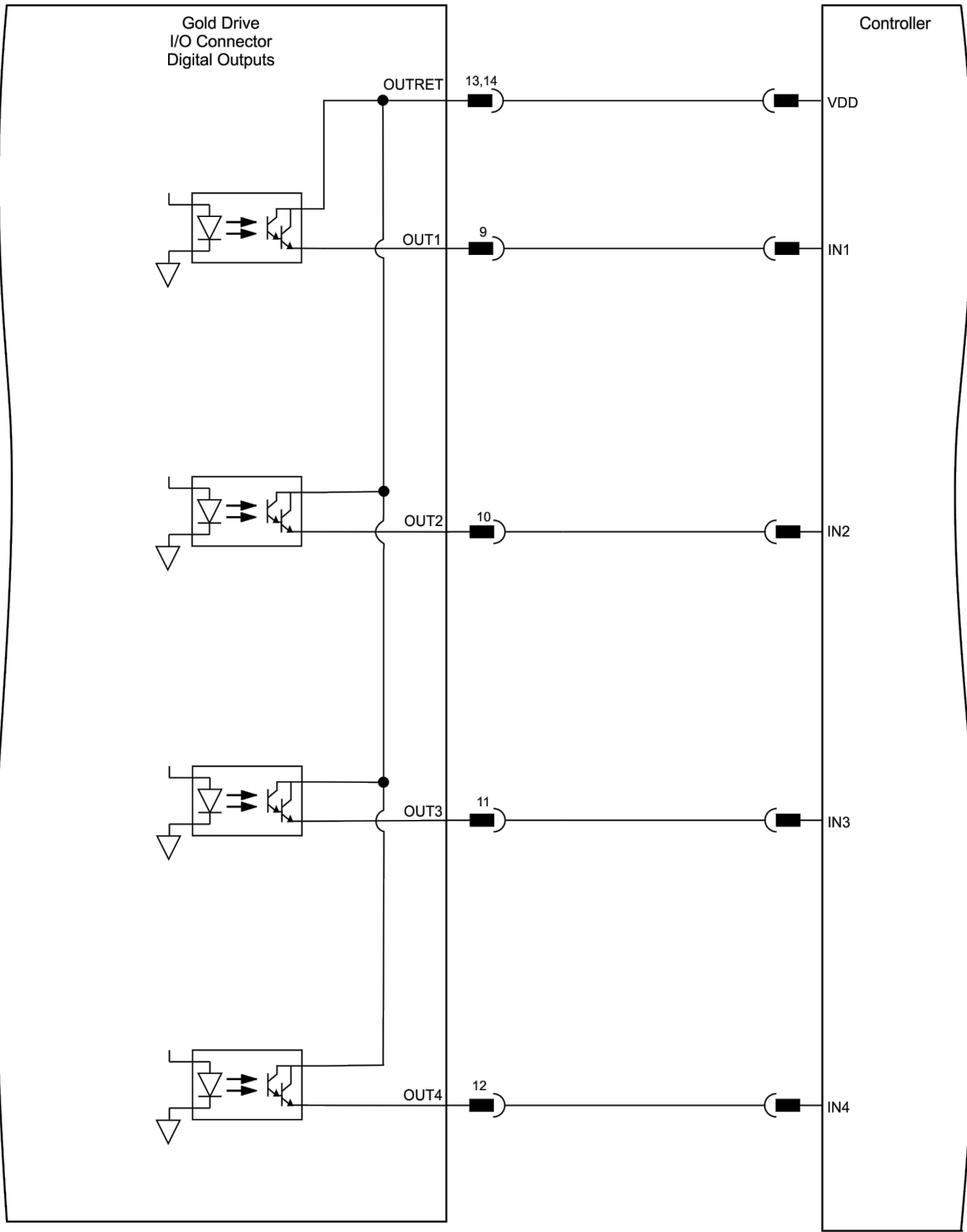

Figure 37: Digital Photodarlington Output Schematic – Source Mode 5V Logic Level



G-SOLTWI134A

Figure 38: Digital Output Connection Diagram Example – Source 5V Logic Option



### 8.4.3. STO (Safe Torque Off)

For full details on STO, see Chapter 9 in the MAN-G-Board Level Modules Hardware manual.

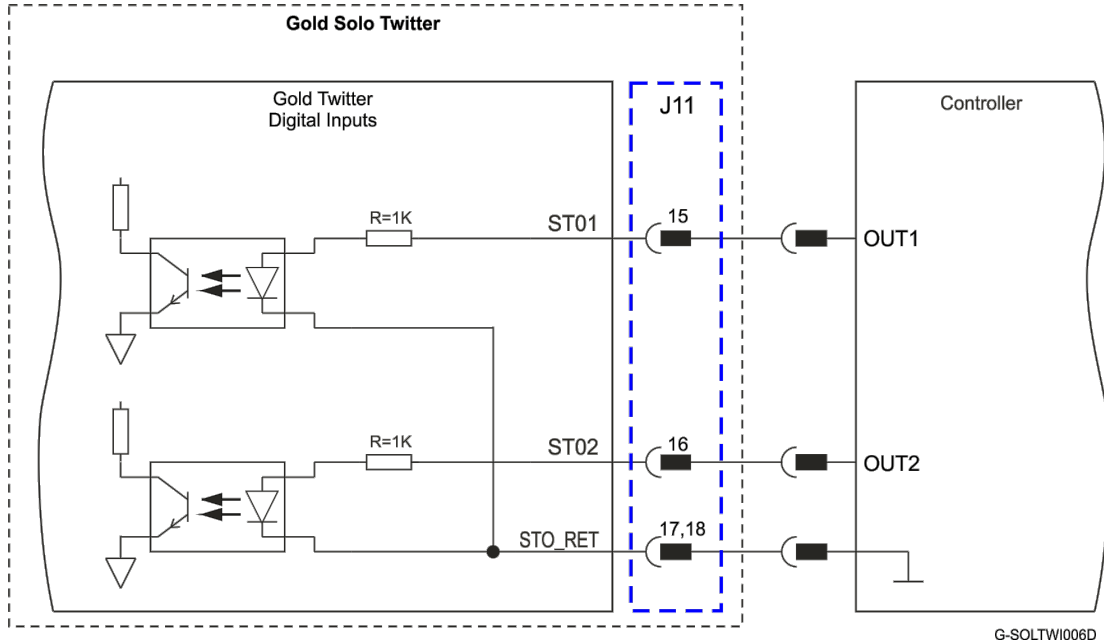

Figure 39: STO Input Connection – 5V Logic

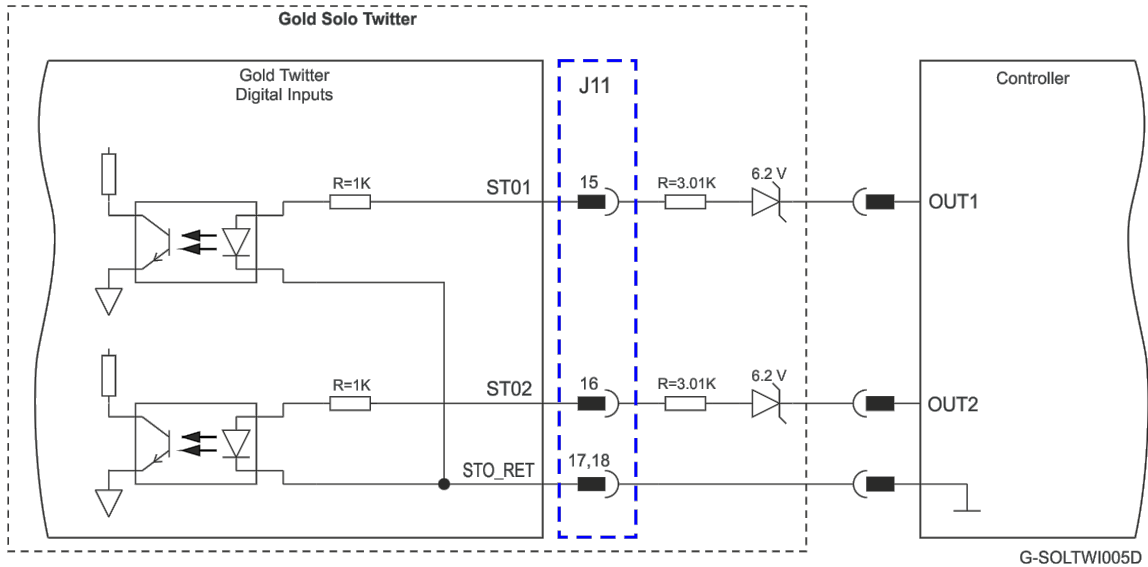

Figure 40: STO Input Connection – PLC (24V Logic)



### 8.4.4. Analog Input

For full details on Analog Inputs, see section 11.3 in the MAN-G-Board Level Modules Hardware manual.

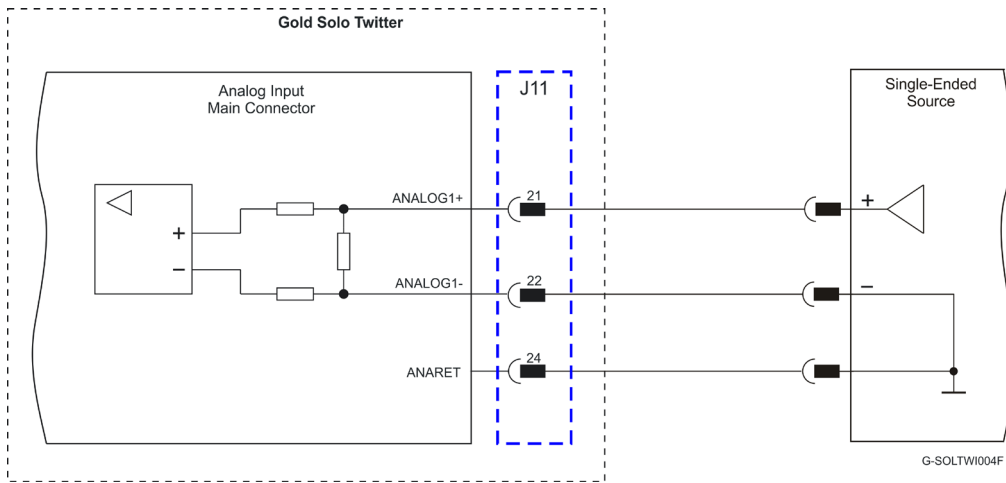

Figure 41: Analog Input

For short distances between the drive and control, 0.5 to 1.0 m wires can be used and shielding is not required. For longer distances than 1.0 m and/or high EMI environment, shielded and twisted wires should be used. Drain wires should be connected to Elmo COMRET.

### 8.4.5. Standard RS-232

Figure 42 describes the Standard RS-232 connection diagram.

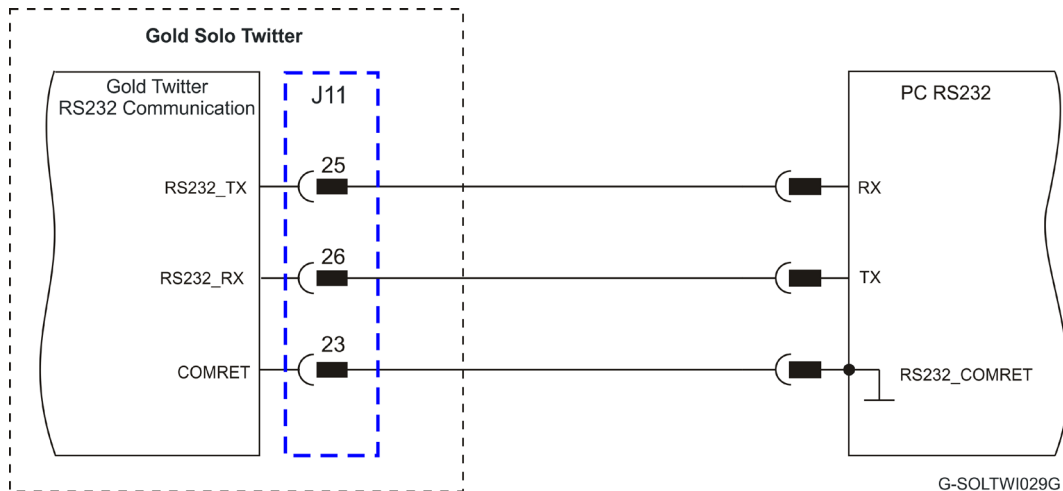

Figure 42: Standard RS-232 Connection Diagram

For short distances between the drive and control, 0.5 to 1.0 m wires can be used and shielding is not required. For longer distances than 1.0 m and/or high EMI environment, shielded and twisted wires should be used. Drain wires should be connected to Elmo COMRET.



### 8.4.6. USB 2.0 Communication (Only for EtherCAT version)

For full details on USB communication, see section 12.1 in the MAN-G-Board Level Modules Hardware manual.

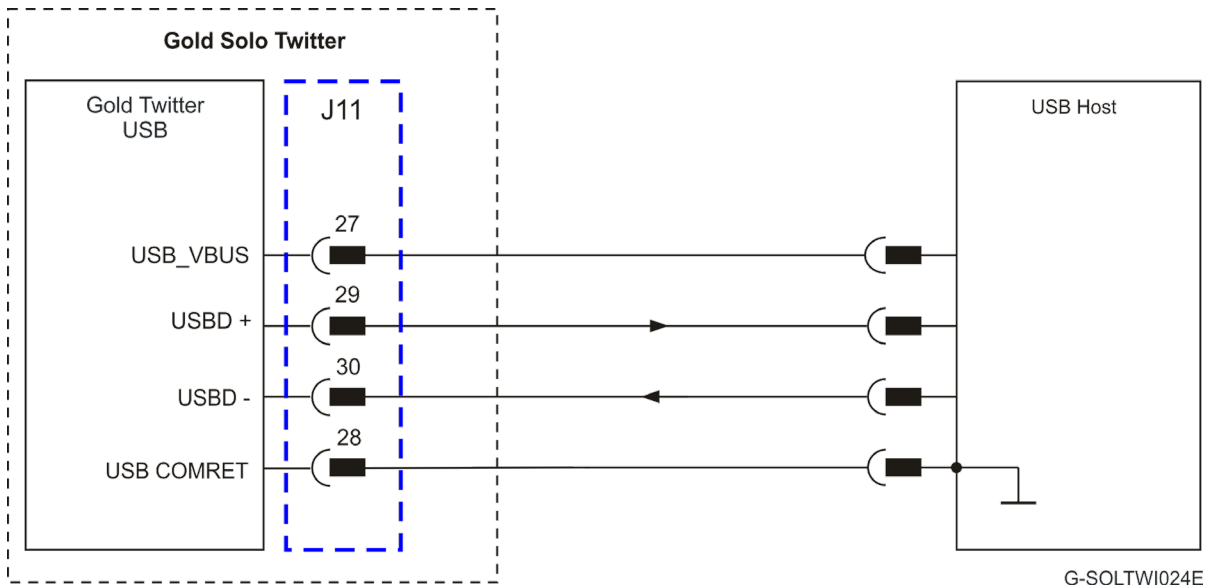

Figure 43: USB Network Diagram

For short distances between the drive and control, 0.5 to 1.0 m wires can be used and shielding is not required. For longer distances than 1.0 m and/or high EMI environment, shielded and twisted wires should be used. Drain wires should be connected to Elmo COMRET.



### 8.5. EtherCAT Communications Version

Fieldbus communications are industrial network protocols for real-time distributed control that allows connection of servo drives. The Gold Solo Double Twitter supports the following EtherCAT fieldbus type industrial network protocol:

Fieldbus Type	Product Number
EtherCAT	G-SOLTWIDXXX/YYYEESV

#### 8.5.1. EtherCAT IN/Ethernet Connector (J17)

Refer to section 12.2 in the MAN-G-Panel Mounted Drives Hardware manual for more details.

Pin (J17)	Signal	Function
1	EtherCAT_IN_TX+/Ethernet_TX+	EtherCAT in/Ethernet transmit +
2	EtherCAT_IN_TX-/Ethernet_TX-	EtherCAT in/Ethernet transmit -
3	EtherCAT_IN_RX+/Ethernet_RX+	EtherCAT in/Ethernet receive +
4	EtherCAT_IN_RX-/Ethernet_RX-	EtherCAT in/Ethernet receive -
5	COMRET	Shield drain wire

Pin Positions	Cable Connector
 <p style="text-align: center;">J17 Pin Numbers</p> <p style="text-align: center;">1 5</p> <p style="text-align: center;">J17</p> <p>G-SOL_DBL_TWI-002B-E</p>	 <p style="text-align: right;">Pin #5</p> <p style="text-align: right;">Pin #1</p> <p style="text-align: right;">G-SOLTW-138C_EC</p> <p style="text-align: center;"><b>Ethernet Cable Connector</b></p>

Table 7: EtherCAT IN / Ethernet Pin Assignments

**Note:** Always use CAT5e cables.

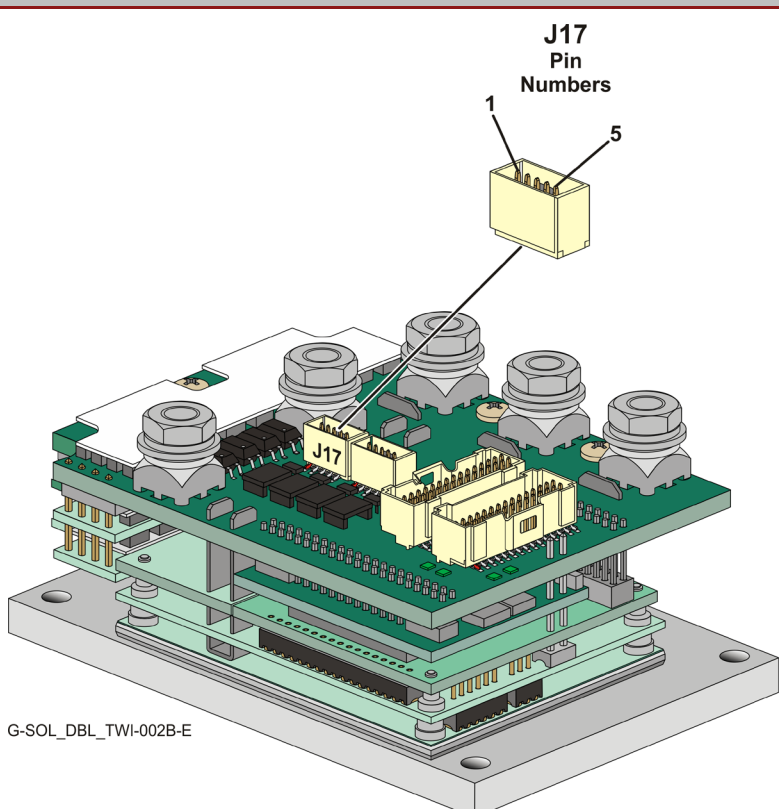
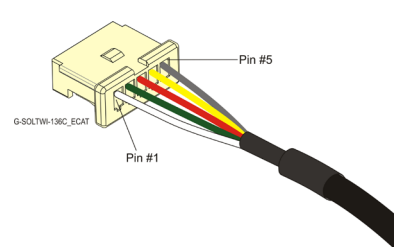

### 8.5.2. EtherCAT OUT Connector (J18)

See Section 12.2 in the MAN-G-Panel Mounted Drives Hardware manual for the electrical diagram.

Pin (J18)	Signal	Function
1	EtherCAT_OUT_TX+	EtherCAT out transmit +
2	EtherCAT_OUT_TX-	EtherCAT out transmit -
3	EtherCAT_OUT_RX+	EtherCAT out receive +
4	EtherCAT_OUT_RX-	EtherCAT out receive -
5	COMRET	Shield drain wire

Pin Positions	Cable Connector
 <p style="text-align: center;"><b>J18 Pin Numbers</b></p> <p style="text-align: center;">1                      5</p> <p style="text-align: center;">J18</p> <p>G-SOL_DBL_TWI-002B-F</p>	 <p style="text-align: center;"><b>Ethernet Cable Connector</b></p>

Table 8: EtherCAT OUT Pin Assignments

**Note:** Always use CAT5e cables.



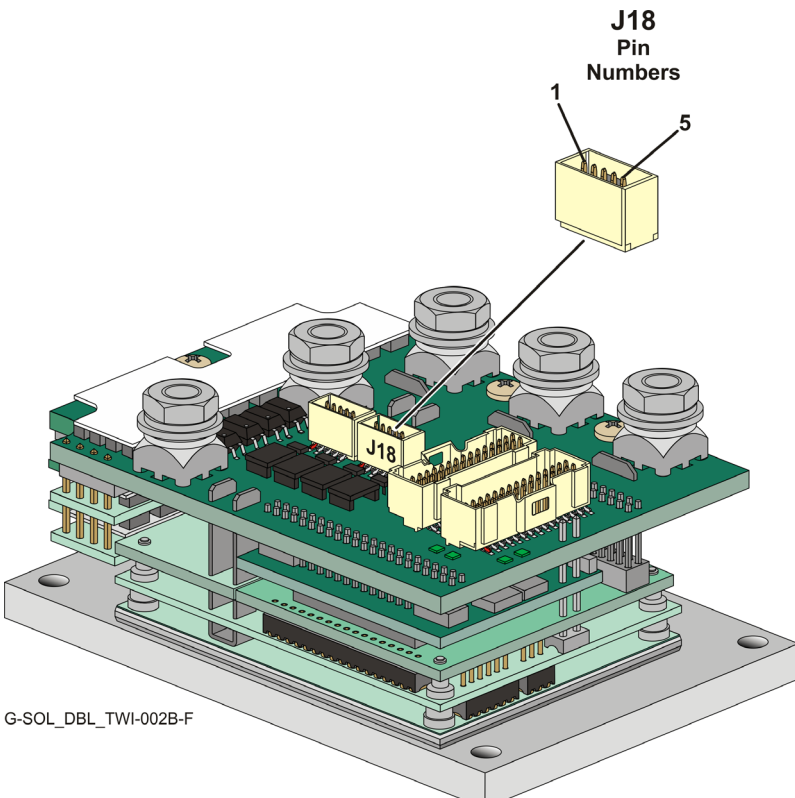
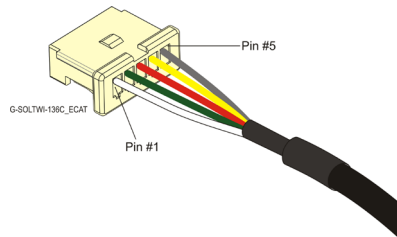

### 8.5.3. EtherCAT Option

For full details on EtherCAT communication, see Section 12.2 in the in the MAN-G-Board Level Modules Hardware manual.

**Note:** The EtherCAT IN port can be configured to an Ethernet Port.

#### 8.5.3.1. EtherCAT Communication

This section only describes the EtherCAT communication, and the pinout drawing of the connector.



**When the EtherCAT is connected and the FoE is in operation, the USB cable connection must be disconnected.**

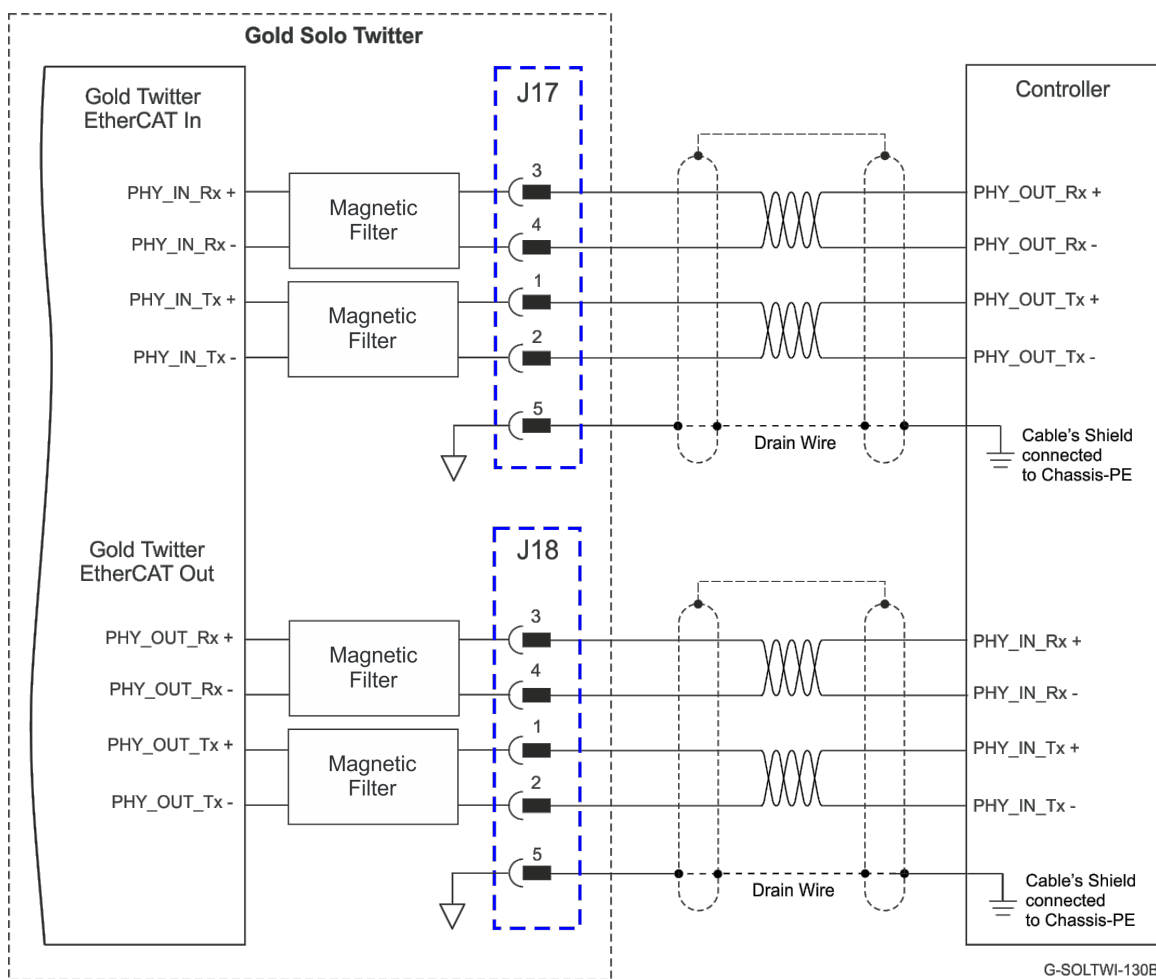

Figure 44: EtherCAT Connection Schematic Diagram

**Note:** Always use CAT5e cables.



### 8.5.3.2. EtherCAT Status Indicator (D2)

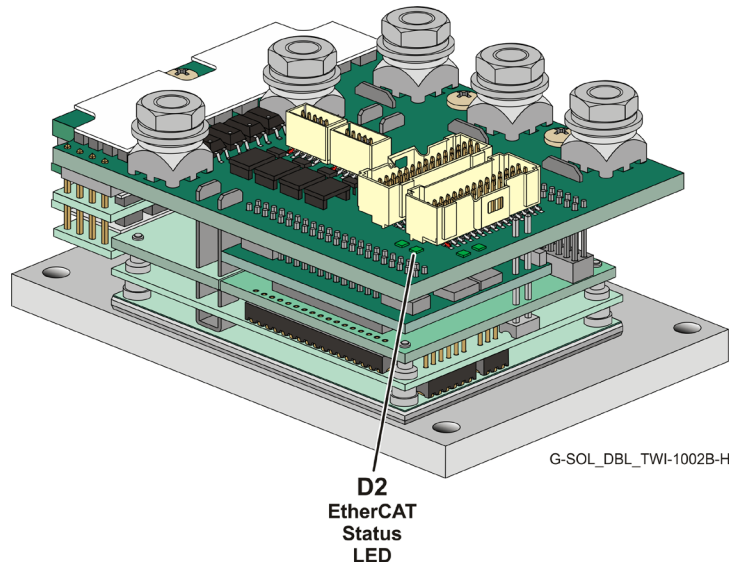

Figure 45: EtherCAT Status LED

The EtherCAT status indicator D2 is a single red/green dual bi-colored LED that combines the green RUN indicator and the red ERROR indicator of the EtherCAT state machine. For further details, see the EtherCAT Application Manual.

### 8.5.3.3. EtherCAT Link Indicators (D3, D4)

The Gold Solo Double Twitter can serve as an EtherCAT slave device. For this purpose it has two Ports J17 and J18, which are designated as EtherCAT In and EtherCAT Out. Each of these Ports has a status LED; D3 EtherCAT In and D4 EtherCAT Out, which are shown in Figure 46.

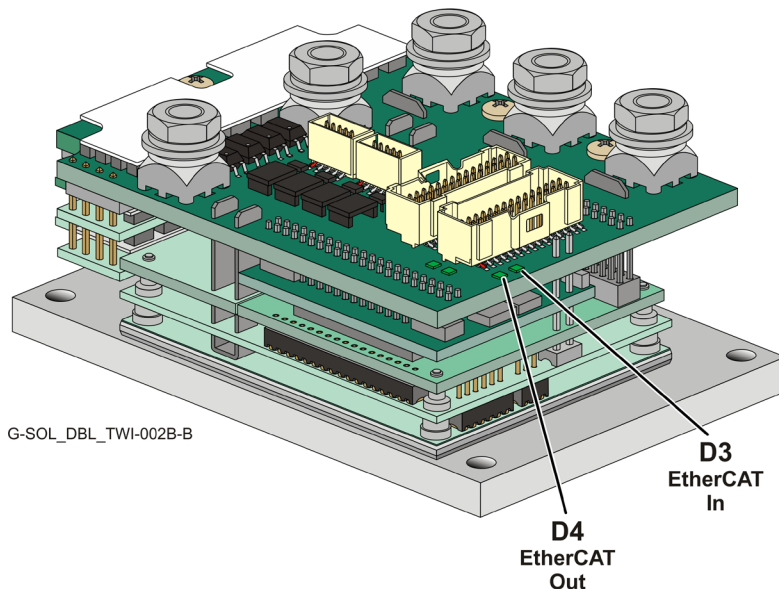

Figure 46: Ethernet Connector LEDs

The green LEDs D3 and D4 are the link/activity indicators. They show the state of the applicable physical link and the activity on that link; blinking green, D3 for the Link Act IN, and D4 for the Link Act OUT.



### 8.6. CAN Communications Version

Fieldbus communications are industrial network protocols for real-time distributed control that allows connection of servo drives. The Gold Solo Double Twitter supports the following CAN fieldbus type industrial network protocol:

Fieldbus Type	Product Number
CAN	G-SOLTWIDXXX/YYSESV

See Section 12.4 in the MAN-G-Panel Mounted Drives Hardware manual for the electrical diagram.

#### 8.6.1. CAN IN Connector (J17)

Pin (J17)	Signal	Function
1	NC	NC
4	CAN_L	CAN_L bus line (dominant low)
3	CAN_H	CAN_H bus line (dominant high)
2	CAN_RET	CAN Return
5	COMRET	Shield drain wire

Pin Positions	Cable Connector
<p>J17 Pin Numbers</p> <p>1 5</p> <p>J17</p> <p>G-SOL_DBL_TWI-005B-C_CAN</p>	<p>Pin #5</p> <p>Pin #2</p> <p>G-SOLTWI-137C_CAN</p> <p>CAN Cable Connector</p>

Table 9: CAN IN Connector Pin Assignments

Note: Always use CAT5e cables.



### 8.6.2. CAN OUT Connector (J18)

Pin (J18)	Signal	Function
1	NC	NC
4	CAN_L	CAN_L bus line (dominant low)
3	CAN_H	CAN_H bus line (dominant high)
2	CAN_RET	CAN Return
5	COMRET	Shield drain wire

Pin Positions	Cable Connector
<p style="text-align: center;">J18 Pin Numbers</p> <p style="text-align: center;">1                      5</p> <p style="text-align: center;">J18</p> <p>G-SOL_DBL_TWI-005B-B_CAN</p>	<p style="text-align: right;">Pin #5</p> <p style="text-align: right;">Pin #2</p> <p style="text-align: right;">G-SOLTWI-137C_CAN</p> <p style="text-align: center;"><b>CAN Cable Connector</b></p>

Table 10: CAN OUT Connectors Pin Assignments

**Note:** Always use CAT5e cables.



### 8.6.3. CAN Option

For full details on CANopen communication, see section 14.3 in the MAN-G-Board Level Modules Hardware manual.

#### 8.6.3.1. Interface

The Gold Solo Double Twitter includes the CAN transceiver, common mode choke, and a CAN Bus Protector against ESD and other harmful transient voltage events.

The following signals describe how to connect CAN to the external connector.

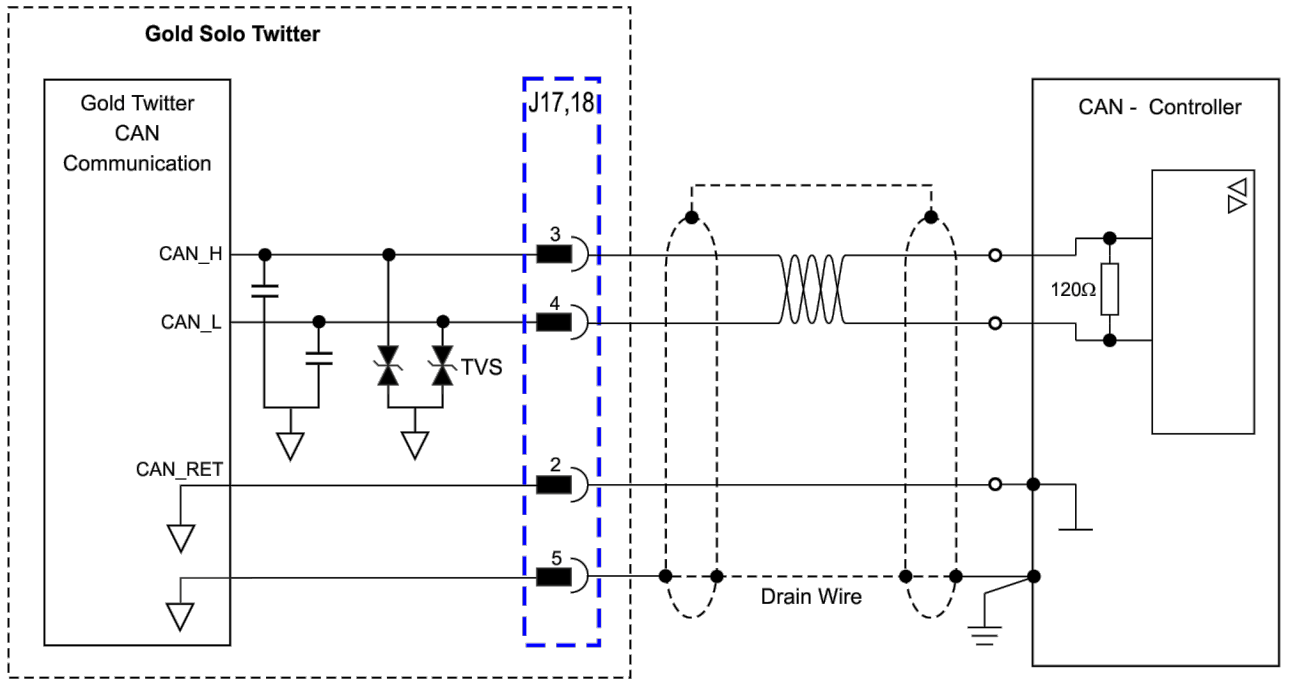

Figure 47: CAN Interface



### 8.6.3.2. CAN Layout

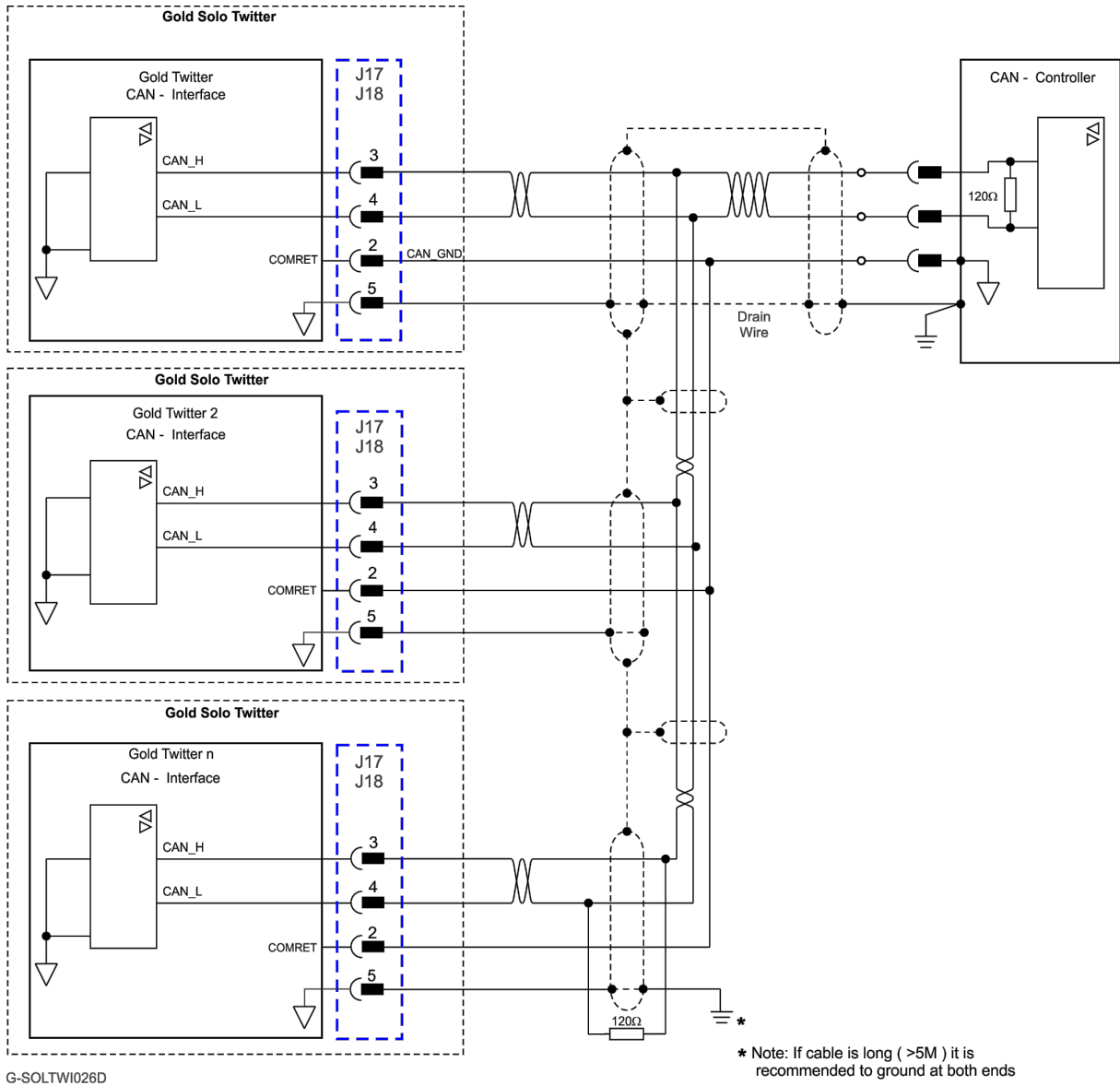

Figure 48: CAN Network Diagram – Drop Off Topology



**Caution:** When installing CAN communication, ensure that each servo drive is allocated a unique ID. Otherwise, the CAN network may “hang”.

**Note:** Daisy chain topology can also be accomplished using J18.

**Note:** Always use CAT5e cables.



## Chapter 9: Powering Up

After the Gold Solo Double Twitter is connected to its device, it is ready to be powered up.



### Caution:

Before applying power, ensure that the DC supply is within the specified range and that the proper plus-minus connections are in order.

### 9.1. Initializing the System

After the Gold Solo Double Twitter has been connected and mounted, the system must be set up and initialized. This is accomplished using the *EASII*, Elmo's Windows-based software application. Install the application and then perform setup and initialization according to the directions in the *EASII User Manual*.

### 9.2. Heat Dissipation

The best way to dissipate heat from the Gold Solo Double Twitter is to mount it so that its heat-sink is attached to the machine chassis. If mounted with its heat-sink suspended, then for best results mount the servo drive faced upwards and leave approximately 10 mm of space between the Gold Solo Double Twitter's heat-sink and any other assembly.

#### 9.2.1. Heat Dissipation Data

Heat Dissipation is shown graphically below. The graphs below describe the Gold Solo Double Twitter.

**It should also be noted that the Gold Solo Double Twitter's Heat Sink can dissipate up to 7.5 W.**

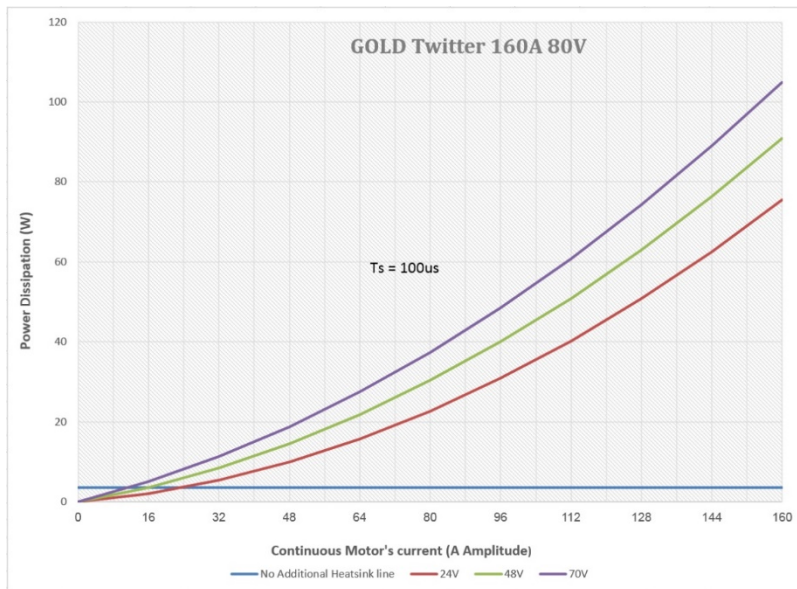

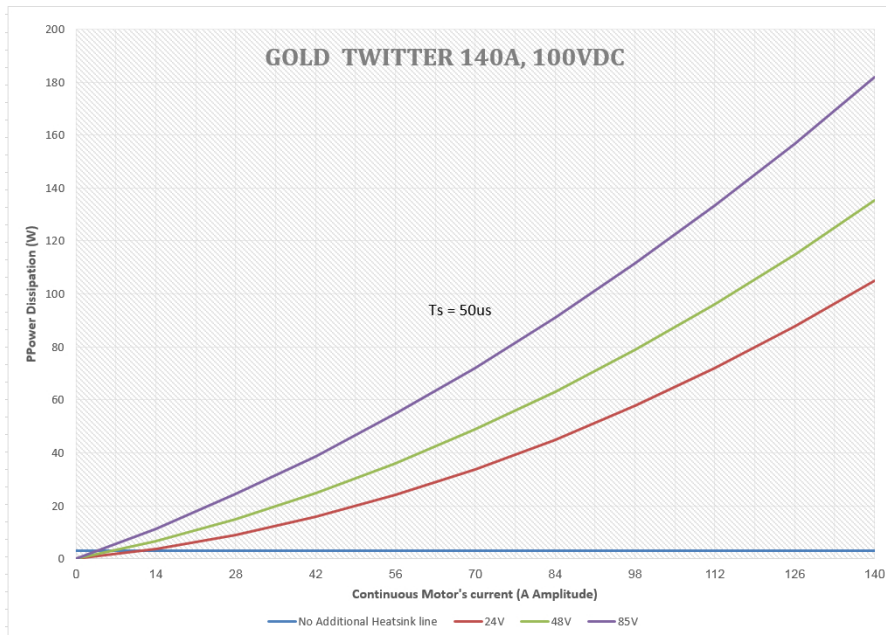
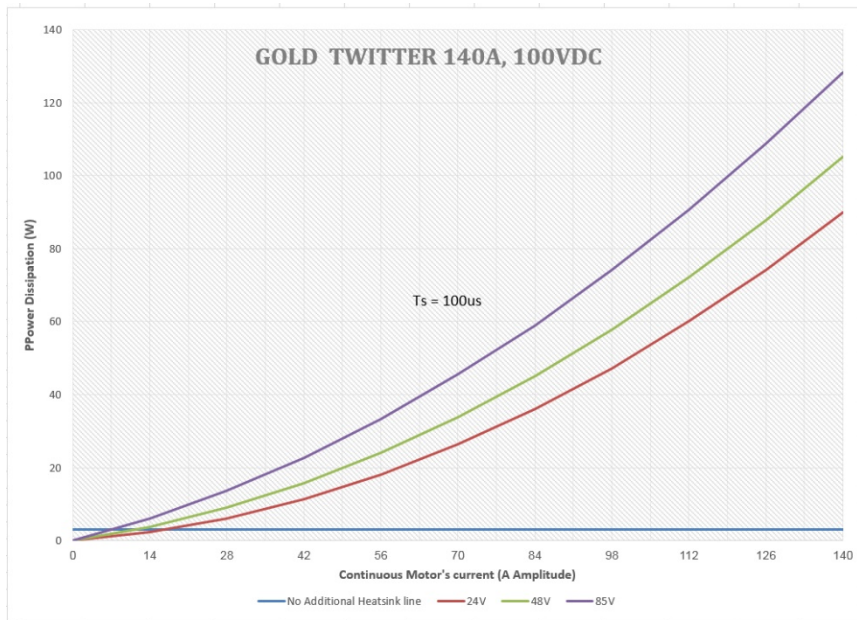
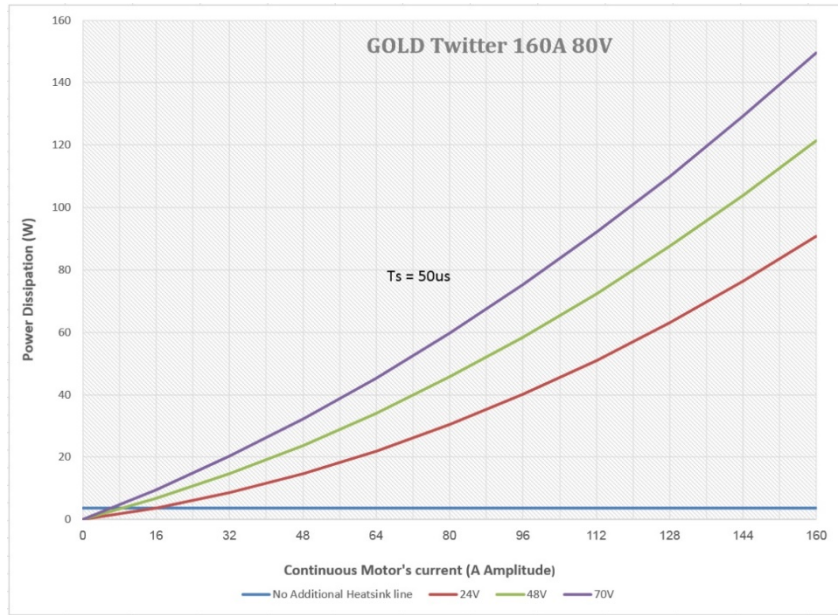



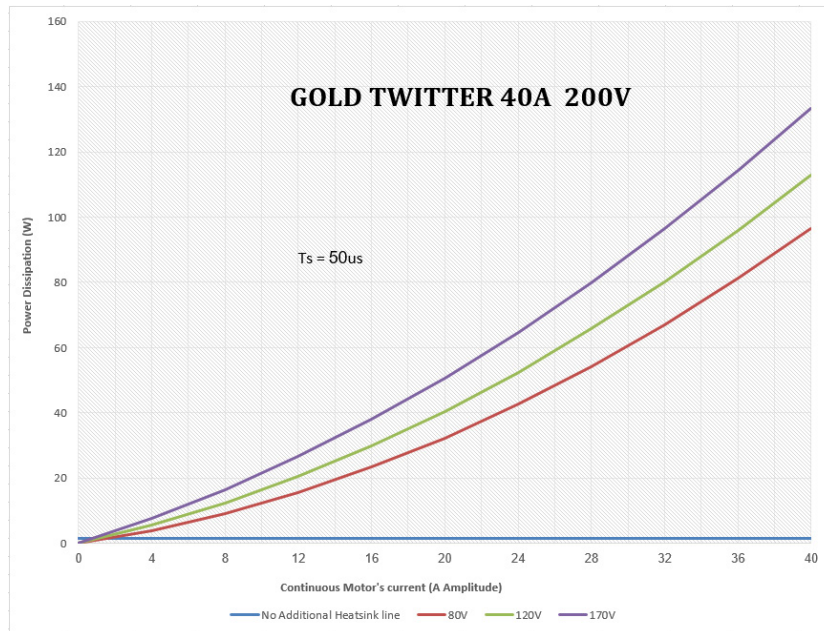
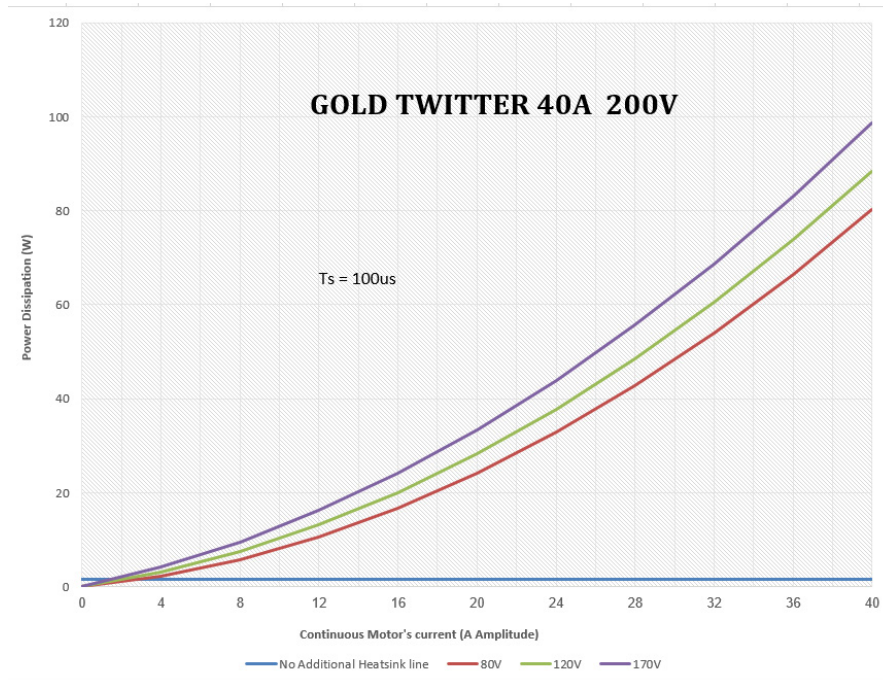

### 9.2.2. How to Use the Chart

The charts above are based upon the theoretical worst-case scenario. The actual test results display a 20% -30% lower power dissipation.

The above charts indicate the net power conversion losses and exclude the control losses.

**To determine if your application heat dissipation requires a heat sink:**

1. Determine the power dissipation according to the "continuous current" and the DC bus voltage curve.  
If the DC bus is not one of the three curves above, estimate the dissipation by interpolation.  
The estimation error is not critical.
2. The chart is calculated for continuous current operation, if the actual operation is pulsed current, add 25% to 30% to the power dissipation of the average (RMS) current.



3. When the Heat-Sink temperature reaches  $\approx 85^\circ\text{C}$ , the Gold Solo Double Twitter will shut down.  
Design the system for continuous operation so that the maximum Heat Sink temperature should be no higher than between  $80^\circ\text{C}$  to  $82^\circ\text{C}$ .
4. If the average heat dissipation is less than  $\approx 4\text{W}$  to  $5\text{W}$  (Average operating power of  $300\text{W}$  to  $600\text{W}$ ) there will be no requirement for an additional external heat sink.  
If the average Heat dissipation is higher than  $4\text{W}$  then an additional heat dissipation means is required, usually by connecting to an additional external heat-sink.
5. When an external Heat-Sink is required, calculate the thermal resistance of the heat sink according to:

$$\theta_{\text{C/W}} = \frac{80^\circ\text{C} - T_{\text{Ambient}}}{\text{Heat Dissipation}}$$



## Chapter 10: Dimensions

This chapter provides detailed technical dimensions regarding the Gold Solo Double Twitter.

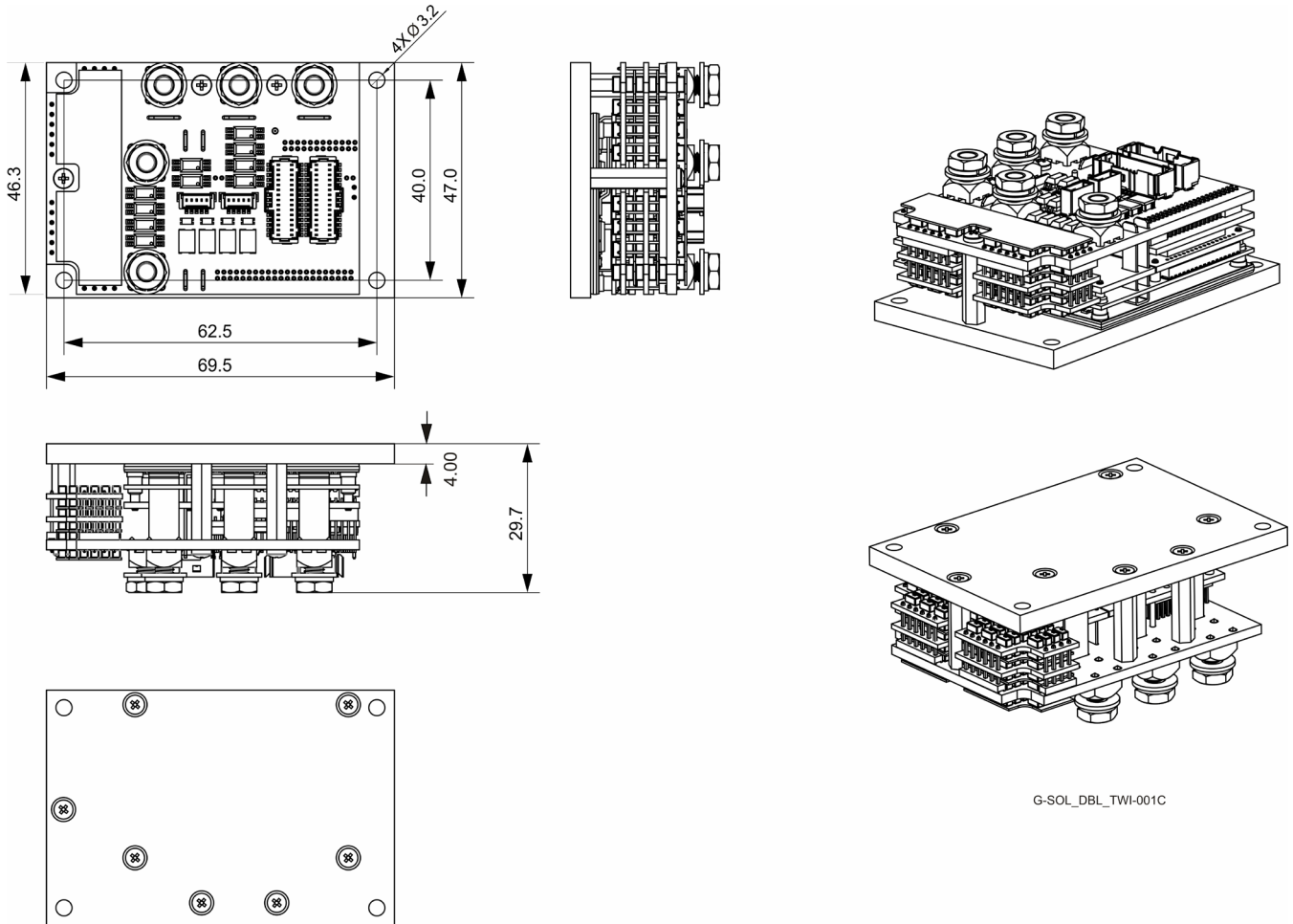

Figure 49: G-Solo Double Twitter –EtherCAT version

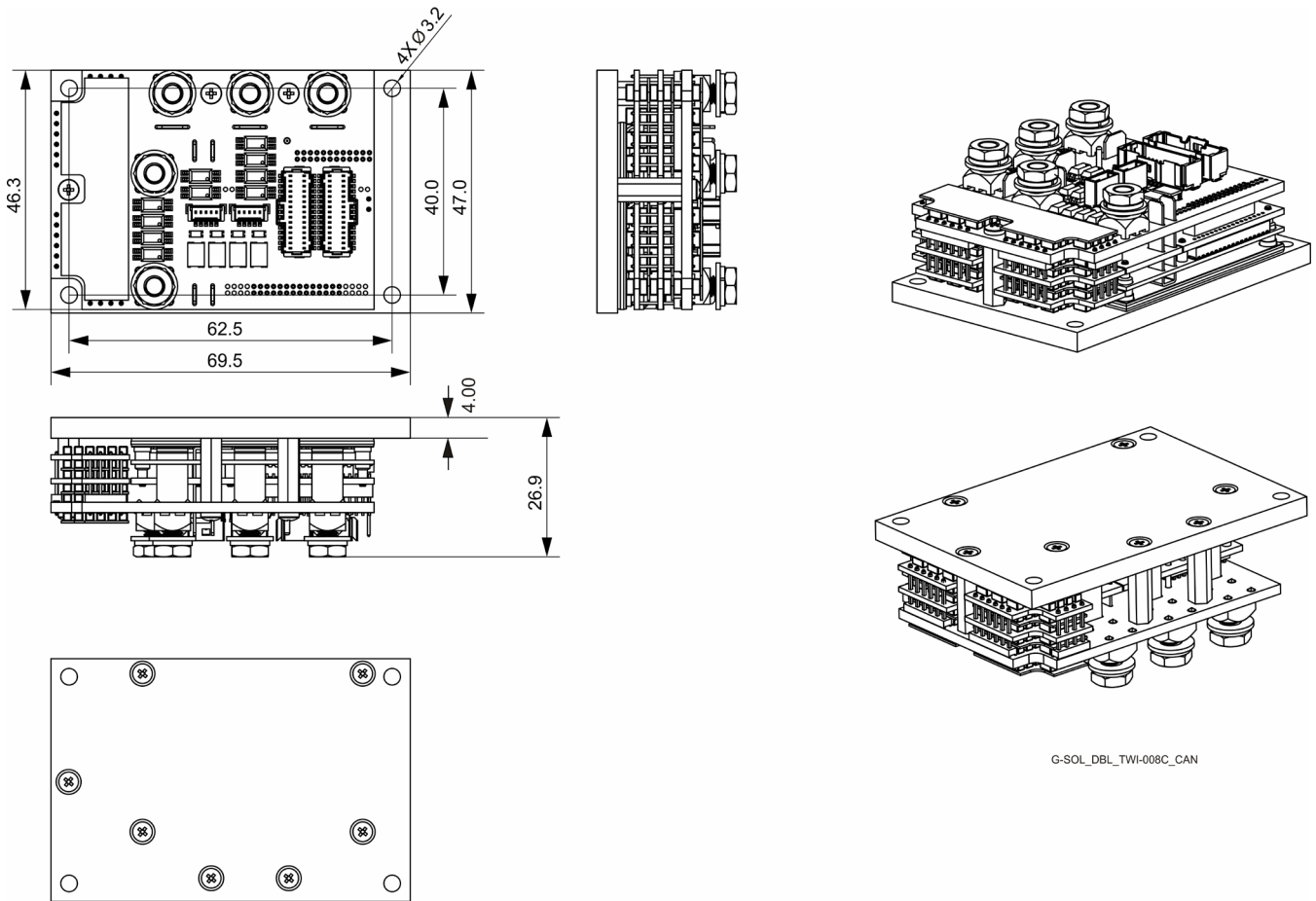

Figure 50: G-Solo Double Twitter –CAN version



## Chapter 11: Cables and Accessories

A Power cable kit can be purchased separately from Elmo for the Gold Solo Double Twitter:

Part Number	Description
CBL-GSOLDTWIPOWKIT01	Kit cable for Power

The following describes the accessory kits available for the Gold Solo Double Twitter.

Part Number	Description
CBL-GSOLTWIKIT03	Kit cable for EtherCAT model
CBL-GSOLTWIKIT04	Kit cable for CAN model
CBL-GSOLTWIKIT05	CONNECTORS AND PINS KIT

A specific Crimping Tool (available for purchase from Elmo) is required to mount extra connecting pins on the wires. A number of wires are provided in the kit as pre-crimped for convenience:



**Crimping Tool**  
**Molex P/N 63819-1500**  
**Elmo P/N TOOL-P000040**



**Pins for Single Row Connector**  
**MOLEX P/N 501334-0100**  
**Pins for Dual Row Connector**  
**MOLEX P/N 501193-3000**

# Inspiring Motion

*Since 1988*

For a list of Elmo's branches, and your local area office, refer to the Elmo site [www.elmomc.com](http://www.elmomc.com)

