

Compumotor

OEM750 Drive OEM750X Drive/Indexer User Guide

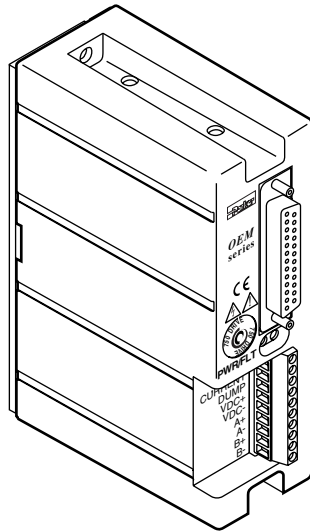

Compumotor Division
Parker Hannifin Corporation
p/n 88-016109-01 B



Important User Information

Installation & Operation of Compumotor Equipment

It is important that Compumotor motion control equipment is installed and operated in such a way that all applicable safety requirements are met. It is your responsibility as a user to ensure that you identify the relevant standards and comply with them. Failure to do so may result in damage to equipment and personal injury. In particular, you should review the contents of the user guide carefully before installing or operating the equipment.

Under no circumstances will the suppliers of the equipment be liable for any incidental, consequential, or special damages of any kind whatsoever, including but not limited to lost profits arising from or in any way associated with the use of the equipment or this user guide.

Safety Warning

High-performance motion control equipment is capable of producing rapid movement and very high forces. Unexpected motion may occur especially during the development of controller programs. KEEP CLEAR of any machinery driven by stepper or servo motors and never touch them while they are in operation.

High voltages exist within enclosed units, on rack system backplanes, and on transformer terminals. KEEP CLEAR of these areas when power is applied to the equipment.

Parker Compumotor constantly strives to improve all of its products. We reserve the right to modify equipment and user guides without prior notice. No part of this user guide may be reproduced in any form without prior consent from Parker Compumotor.



For assistance in the United States, contact:
Compumotor Division of Parker Hannifin
5500 Business Park Drive
Rohnert Park, CA 94928
Telephone: (800) 358-9070
Fax: (707) 584-8015
e-mail: tech_help@cmotor.com
Internet: <http://www.compumotor.com>



For assistance in Europe, contact:
Parker Digiplan
21 Balena Close
Poole, Dorset
England BH17 7DX
Telephone: 0202-690911
Fax: 0202-600820



Compumotor Division

User Guide Change Summary

OEM750/750X Drive /Indexer User Guide

Revision B
January 2000

The following is a summary of the primary technical changes to this document since the previous version was released. This document, p/n 88-016109-01 **B**, supersedes 88-016109-01 **A**.

New OEM750X Features

New features — Software flow control, device ID string, communication error checking, and RS-485 option have been added to the OEM750X. See Software Reference Guide, p/n 88-013785-01 Rev C or higher (NOTE: This only applies to firmware 92-016638-01).

Speed/Torque Information (pg 48)

Clarification — Parallel connected motors are limited to 50% duty cycle when operated above 5 rps. For greater than 50% duty cycle above 5 rps, you must connect the motor in series. Fan cooling the motor will increase duty cycles above 5 rps.

Clarification — Allow +/- 10% torque tolerance due to motor tolerance.



**Product Type: OEM750 Step Motor Drive
OEM750X Step Motor Indexer/Drive**

The above products are in compliance with the requirements of directives

- **72/23/EEC Low Voltage Directive**
- **93/68/EEC CE Marking Directive**

The OEM750 and OEM750X, when installed according to the procedures in the main body of this user guide, may not necessarily comply with the Low Voltage Directive (LVD) of the European Community. To install the OEM750 and OEM750X so that they comply with LVD, you must follow the additional procedures described in *Appendix A, LVD Installation Instructions*. If you do not follow these instructions, the LVD protection of the product may be impaired.

The OEM750 and OEM750X Series of drives are sold as complex components to professional assemblers. As components, they are not required to be compliant with Electromagnetic Compatibility Directive 89/336/EEC. However, information is offered in *Appendix B, EMC Installation Guide* on how to install the OEM750 and OEM750X in a manner most likely to minimize the effects of drive emissions and to maximize the immunity of drives from externally generated interference.



Compumotor Division

CONTENTS

1 INTRODUCTION	1
OEM750 Drive Description	1
Related Products	3
OEM750X Drive/Indexer Description	4
Features	4
2 INSTALLATION	5
OEM750/OEM750X Ship kit	5
Quick Test	6
Quick Test: OEM750 with Separate Indexer	13
Quick Test: OEM750X	14
DIP Switch Functions	16
OEM750 Inputs and Outputs	19
Step Input	19
Direction Input Signal Specification	20
Remote Input	20
Fault Output	21
Gear Shift Input	22
OEM750X Inputs and Outputs	23
Step (Pin 1) & Direction (Pin 2) Outputs	23
CW (Pin 3) & CCW (Pin 4) Limit Inputs	24
Home Position Input (Pin 5)	25
Output #1 (Pin 10) and Output #2 (Pin 8)	25
Dedicated Fault Output (Pin 9)	26
Sequence Inputs #1 – #3 (Pins 11 – 13)	26
RS-232C—Tx (Pin 14), Rx (Pin 15), and Ground (Pin 7)	27
Shutdown Output (Pin 16)	28
Closed Loop Operation	28
Encoder Inputs A, B, Z (Pins 17–19)	29
Trigger Inputs #1 – #3 (Pins 20 – 22)	29
Address Inputs #1 – #3 (Pins 23 – 25)	30
Daisy Chaining	30
Choosing a Power Supply	32
Current (Amps)	33
Power Dump	33
Mounting	34
Panel Layout	35
Motor Mounting	41
Attaching the Load – Couplers	42
3 TUNING & SPECIFICATIONS	43
Short-Circuit Protection	43
Low Speed Resonance	43
Mid-Range Instability	43
Tuning Procedure	44
Determining Motor Resonance	45
Tuning the Drive to the Motor	46
Adjusting Motor Current Waveforms	46
Performance Specifications	47

Motor Specifications 47
 Motor Part Number – Cross Reference Table 47
 Speed/Torque Curves 48
 Motor Specifications—23 Frame Size 51
 Motor Specifications—34 Frame Size 52
 Motor Dimensions 53
Encoder Specifications 55

4 TROUBLESHOOTING 57

Drive Maintenance 57
Motor Maintenance 57
Reducing Electrical Noise 57
Problem Isolation 58
 Front Panel LEDs 59
 Common Problems and Solutions 59
Testing the Motor 62
RS-232C Problems 63
Software Debugging Tools 64
Returning the System 64

APPENDIX A: LVD INSTALLATION INSTRUCTIONS 67

Environmental Conditions 67
Electrical 67
Mechanical 69
Servicing the OEM750/OEM750X 69
Thermal Safety 69
Sonic Pressure 69
Table of Graphic Symbols and Warnings 70

APPENDIX B: EMC INSTALLATION GUIDE 71

General Product Philosophy 71
Safety Considerations 71
General Considerations 72
 External Enclosures 72
 AC Supply Filtering 72
 Control Signal Connections 73
 Motor Cabling 73
 Ferrite Absorber Specifications 73
 Handling and Installing the Ferrite Absorbers 74
 R-Clamp Installation Details 74
OEM Series Products 76
 External Enclosure 76
 Filtering the DC Power Supply 76
Motor Connections 78
 Compumotor Motors, and other Motors With
 Non-Removable Cabling 78
 Compumotor RS Series Motor with C10 Option 80
 Other Motors with Removable Cabling 80
 Motor Cables 81
 Motor Feedback Cables 82
 Motors 82
 Control Signal Wiring 83
 Communications 83

INDEX 85

How To Use This User Guide

This user guide is designed to help you install, develop, and maintain your system. Each chapter begins with a list of specific objectives that should be met after you have read the chapter. This section will help you find and use the information in this user guide.

ASSUMPTIONS

To use this product and its instructions effectively, you should have a fundamental understanding of the following information.

- Electronics concepts (voltage, switches, current, etc.)
- Motion control concepts (torque, velocity, distance, force, etc.)

USER GUIDE CONTENTS

Chapter 1: Introduction

This chapter provides a description of the product and a brief account of its specific features.

Chapter 2: Installation

This chapter contains a ship kit list of items you should have received with your OEM750 or OEM750X. Instructions to mount and connect the system properly are included. Upon completion of this chapter, your system should be completely installed and ready to perform basic operations.

Chapter 3: Tuning & Specifications

This chapter contains information on system performance specifications (speed/torque curves, environmental specifications, etc.). Also provided are procedures for tuning the drive to optimize the motor performance.

Chapter 4: Troubleshooting

This chapter contains information on identifying and resolving system problems. Descriptions of LED signals, debugging tools, problems/solutions table are included.

Appendix A: LVD Installation Instructions

This appendix contains information on installing the OEM750/OEM750X so that it complies with the Low Voltage Directive of the European Community.

Appendix B: EMC Installation Guide

This chapter contains information on how to install the OEM750/OEM750X so that the effects of drive emissions are minimized, and drive immunity to externally generated interference is maximized.

INSTALLATION PREPARATION

Before you install this product, complete the following steps:

1. Review this user guide. Become familiar with the user guide's contents so that you can quickly find the information you need.
2. Develop a basic understanding of all system components, their functions, and interrelationships.
3. Complete the basic system configuration and wiring instructions (in a simulated environment, not a permanent installation) provided in *Chapter 2, Installation*.
4. Perform as many basic functions as you can with the preliminary configuration. Try to simulate the task(s) that you expect to perform when you permanently install your application (however, do not attach a load at this time). This will give you a realistic preview of what to expect from the complete configuration.
5. After you have tested the system's functions and become familiar with the system's basic features, carefully read the rest of Chapter 2.
6. After you have read all of Chapter 2 and clearly understand what must be done to properly install the system, begin the installation process. Do not deviate from the instructions provided.
7. Before you customize your system, check all of the system functions and features to ensure that you have completed the installation process correctly.

The successful completion of these steps will prevent subsequent performance problems and allow you to isolate and resolve potential system difficulties before they affect your system's operation.

SOFTWARE REFERENCE MANUAL

A separate Software Reference Manual contains descriptions for all software commands applicable to the OEM750X.

WARNINGS & CAUTIONS

Warning and caution notes alert you to problems that may occur if you do not follow the instructions correctly. Situations that may cause bodily injury are presented as warnings.

Situations that may cause system damage are presented as cautions. Examples are shown below.

WARNING

Do not touch the motor immediately after it has been in use for an extended period of time. The motor may be hot.

CAUTION

System damage will occur if you power up the system improperly.

This page left blank intentionally.

Introduction

Chapter Objective

The information in this chapter will enable you to:

- Understand the product's basic functions and features

OEM750 Drive Description

The OEM750 Drive is optimized to operate size 23 and 34 two-phase permanent magnet hybrid step motors. It is a high-performance module around which the Original Equipment Manufacturer (OEM) can design a motion control system. The drive offers a basic set of features designed to meet the needs of most customers. It is compatible with all Compumotor indexers. A typical system is shown below.

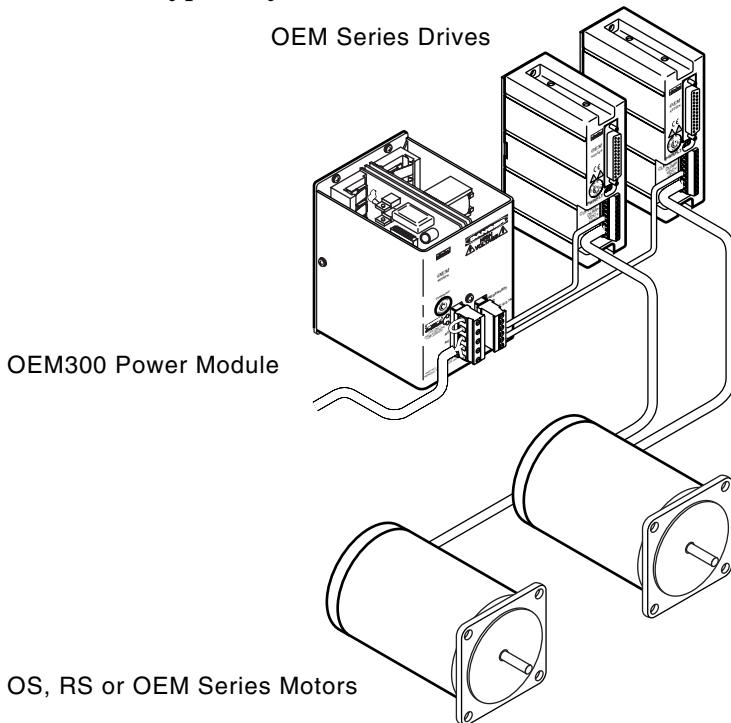

OEM Series Products – A Typical System

The OEM750 is small and convenient to use. It installs with only two screws; the screws also provide grounding and captivate the cover. Its right-angle screw terminal allows side-by-side mounting, and its small footprint maximizes cabinet space. The snap-on molded cover is removable for drive configuration, and helps provide a barrier against environmental contamination. The drive is the same size as a 3U Eurorack card. Its standard 25 pin D-connector is compatible with universally available connectors.

The drive is designed for reliability and manufacturability. It uses surface mount components, MOSFET technology and a custom designed ASIC to improve reliability, conserve space, and reduce cost.

INPUT POWER

The OEM750 requires a single external power supply. The drive accepts 24VDC to 75VDC for its power input.

MOUNTING

The drive is fully enclosed, and uses a *heatplate* technique to provide a heat dissipation path. You must attach the OEM750 to a suitable heat-dissipating mounting surface.

DIP SWITCHES

DIP switches are located inside the OEM750. During the installation procedure, you will set these DIP switches to scale the drive for resolution, waveform and other functions.

INPUT & OUTPUT

All communications take place through the OEM750's 25-pin D-connector. Available inputs and outputs are:

- Step Input
- Direction Input
- Remote Input
- Fault Output
- Gear Shift Input

POTENTIOMETERS

Two potentiometers are located on top of the OEM750 Drive. They are adjusted during the tuning process, to match the

drive's electrical characteristics to the motor's individual characteristics.

ANTI-RESONANCE

All step motors are subject to mid-range instability, or oscillations. The OEM750 has an *anti-resonance* circuit that provides aggressive and effective electronic damping of these oscillations.

PROTECTIVE CIRCUITS

Several circuits in the OEM750 automatically provide protection for the drive.

- Over-Temperature Protection
- Short Circuit Protection
- Power Dump for Regeneration (requires a user-supplied external resistor)

Related Products

The OEM750 Drive has an internal slot where an indexer circuit board can be installed at the factory. The resulting product is referred to as an OEM750X.

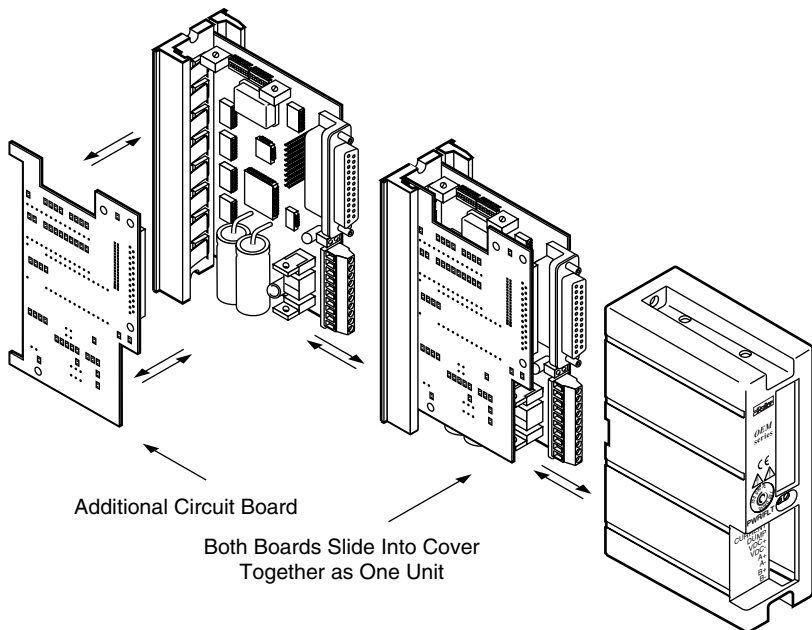

Additional Circuit Board Can Mount Internally

OEM750X Drive/Indexer Description

The OEM750X Drive/Indexer is the same drive product as the OEM750, but it includes an indexer (position controller). The OEM750X is the same size as the OEM750 and it incorporates the same design technologies.

The indexer uses commands from Compumotor's popular and easy to use X Series Language. The indexer also provides additional I/O control and communication.

Features

The OEM750/OEM750X requires an external power supply. It uses 24VDC - 75VDC for its power input. Compumotor's motors are two-phase hybrid motors (permanent magnet type). Four, six, or eight leaded motors may be used, with the internal phases connected for either parallel or series operation. The motor's inductance cannot drop below 0.2 mH. *For best performance, motor inductance should be between 1 mH and 10 mH, but motors with inductance ratings as low as 0.2 mH or as high as 80 mH may be used.*

The OEM750/OEM750X provides the following features:

- Electronic Damping
- Microprocessor controlled microstepping provides smooth operation over a wide range of speeds
- Full short circuit protection for phase-to-phase and phase-to-ground short circuits
- Motor regeneration protection
- Overtemperature protection
- Uses low inductance motors for improved high-speed performance (23, 34 frame size motors available with torques from 35 - 400 oz-in)
- Three-state current control for reduced motor/drive heating
- LED status indicators: **POWER** and **FAULT** (latched)
- Optically coupled step, direction, and shutdown inputs are compatible with all Compumotor indexers (25 pin D-connector)
- A fault output to signal other equipment if a fault occurs
- 24VDC - 75VDC single power input
- 16 DIP switch selectable motor resolutions (200 - 50,800 steps/rev)
- 2 MHz step input
- Waveform correction and phase offset for improved smoothness
- Built-in indexer (position controller)
 - -M2 option allows users to store programmed sequences in nonvolatile memory
 - I/O for motion and basic machine coordination

Installation

Chapter Objectives

The information in this chapter will enable you to:

- Verify that each component of your system has been delivered safely and completely
- Become familiar with the system components and their interrelationships
- Ensure that each component functions properly by bench testing
- Mount the drive within recommended thermal specifications

OEM750/OEM750X Ship kit

Inspect the OEM750 or OEM750X upon receipt for obvious damage to its shipping container. Report any such damage to the shipping company. Parker Compumotor cannot be held responsible for damage incurred in shipment. You should have received either a drive (OEM750) or drive/indexer (OEM750X). Compare your order with the units shipped.

Part	Part Number
OEM Microstepping Drive	OEM750
OEM Microstepping Drive/Indexer	OEM750X

The following option may be used with the OEM750X.

Option	Description
-M2	Nonvolatile Memory (2k BBRAM)

The following motor(s) may be used with the OEM750 and OEM750X. Compare your order with the motors shipped.

Part	Part Number
Size 23—1/2 Stack Stepping Motor	OS2HA (OEM57-40)
Size 23—1 Stack Stepping Motor	OS21A (OEM57-51)
Size 23—2 Stack Stepping Motor	OS22A (OEM57-83)
Size 34—1 Stack Stepping Motor	RS31B (OEM83-62)
Size 34—2 Stack Stepping Motor	RS32B (OEM83-93)
Size 34—3 Stack Stepping Motor	RS33B (OEM83-135)

The motors above are single-shafted. Motors can be purchased with a double-shaft option.

The following accessories are available.

Accessories	Part Number
OEM750/OEM750X User Guide	88-016109-01
OEM Series Software Ref. Guide	88-013785-01
Low Current Heatsink	OEM-HS1
High Current Heatsink	OEM-HS2

Quick Test

Use the following procedure to have your drive perform its *automatic test* function. Once you set DIP switches, connect the motor, and apply DC power, the automatic test will begin—the motor will alternately turn in the clockwise and counterclockwise direction. This will verify that the OEM750 (or the amplifier portion of an OEM750X), motor, motor cable, and power supply work properly as a system.

This is a *bench top* procedure—you can perform it before you connect an indexer, mount the drive, or mount the motor. Full installation instructions follow this section.

An additional procedure will verify operation of the internal indexer in an OEM750X drive.

You will need the following:

- Flathead screw driver (1/10")

CAUTION

The drive and motor should be mounted to a heatsink. Drive mounting does not affect the following tests, but operating the OEM750/OEM750X and motor for extended periods without proper mounting can cause the drive to fault due to overheating. Possible motor damage may occur. When you complete the quick tests, remove power to the drive.

Perform installation and test procedures in a properly grounded environment. Compumotor recommends the use of a grounding strap.

1. Remove the cover by applying pressure to the 25 pin D-connector. With the cover off, the DIP switches will be exposed, as shown in the next drawing.

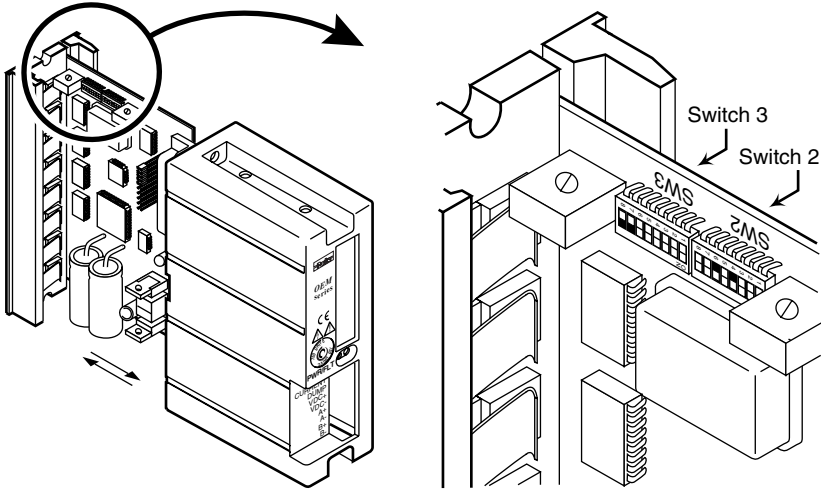

DIP Switch Location

2. To test the system, you will use the Automatic Test function. To enable the function, turn DIP switch SW3-#3 to the *off* position. When power is applied to the drive with SW3-#3 in the *off* position, the Automatic Test function will rotate the motor in an Alternating mode approximately 6 revolutions at 1 rps.

If you are testing an OEM750 with a separate indexer, or an OEM750X, you will use the indexer to command the motor to turn; you will not use the automatic test function. Therefore, set DIP switch SW3-#3 to the *on* position to disable the automatic test function.

3. Set the current loop gain DIP switches, SW3-#4 – SW3#6.

If you use a Compumotor OEM Series, OS Series, or RS Series motor, you can leave the switches in their default position for the purposes of this Quick Test (SW3-#4 = on, SW3-#5 = on, SW3-#6 = off).

The current loop gain adjustment allows you to configure the drive to maximize your system's performance. If you use the default switch position for this Quick Test now, be sure that when you complete your final installation later, you reset these switches for your particular motor. For instructions, see *DIP Switch Functions* following this *Quick Test* section.

If you use a non-Compumotor motor, see *DIP Switch Functions* following this *Quick Test* section for instructions on setting the current loop gain DIP switches. After you properly set the switches, proceed to *Step 4* below.

4. Slide the drive cover back on.

- Attach the motor (to A+, A-, B+, B-). Do not connect the motor to the load at this time. Compumotor OS Series (OEM size 23) motors may be wired in a series or parallel configuration. However, if you are using a 75VDC power supply (such as an OEM300), we recommend that you use a series configuration. A parallel configuration should be used when the power supply is 24VDC - 48VDC. Parallel configurations will cause the drive to dissipate slightly more heat than a series configuration. This increase in drive temperature will not affect the drive's performance, but it may adversely affect heat-sensitive devices that are stored within the same enclosure.

The next drawings show wiring instructions for frame size 23 motors.

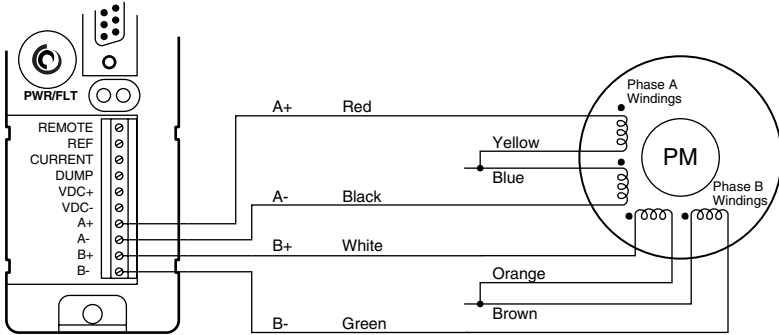

Motor Wiring: Size 23, OS and OEM57 Motors – Series Wiring

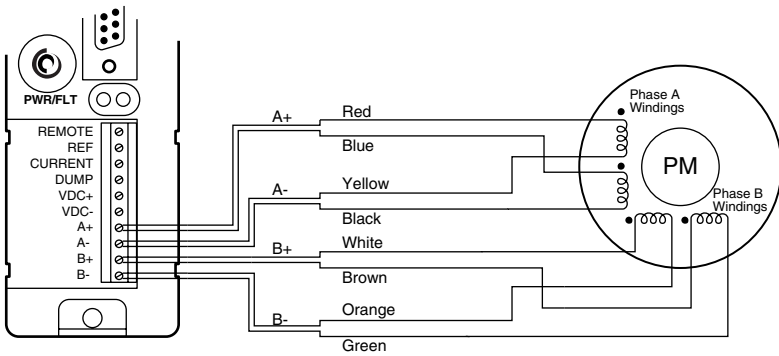

Motor Wiring: Size 23, OS and OEM57 Motors – Parallel Wiring

The next drawings show wiring instructions for frame size 34 motors.

Compumotor's size 34 motors should only be used in a parallel wiring configuration. To achieve maximum performance, you must use a 75VDC power supply, such as a Compumotor OEM300. However, lower voltage power supplies may be used (24 - 75VDC). The lower voltage power supply will not adversely affect the system's low-speed performance, but it will not yield the optimum high-speed performance achieved by using the 75VDC power supply.

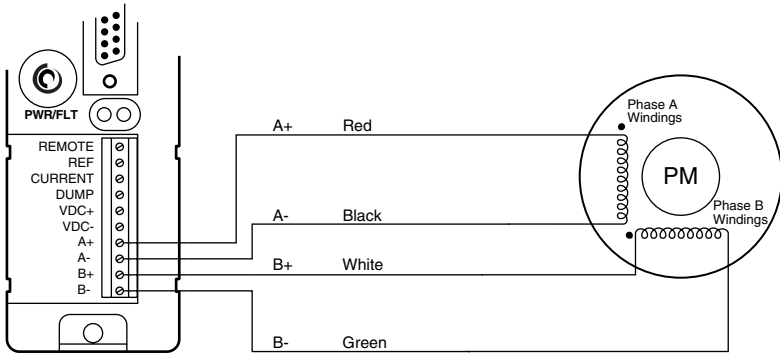

Motor Wiring: Size 34, OEM83 Motors – Parallel Wiring

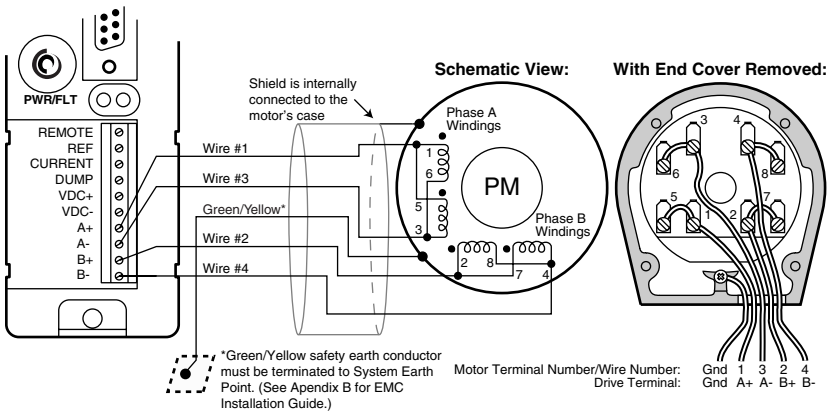

Motor Wiring: Size 34, RS Motors, C10 (NPS) Endbell Construction – Parallel Wiring

6. Set motor current by connecting a 1/4 watt resistor between **REF** and **CURRENT**, as shown in the drawing below.

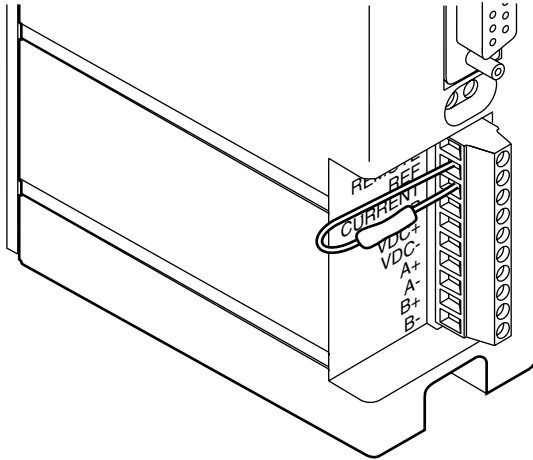

Motor Current Selection Resistor

Motor Current/Resistor Settings for Compumotor Motors

The next table shows motor current settings for Compumotor OS and RS motors. Choose a resistor from the table that matches drive current to the motor your are using. DIP switches that set the current range—SW3-#7 and SW3-#8—should be in the *off* position for these resistor values (*off* is the factory default position).

Motor Size

Size 23	Current	Resistor	Voltage
OS2HA S (OEM57-40 S)	2.65A	21.0 kΩ	48 - 75VDC
OS2HA P (OEM57-40 P)	5.3A	5.76 kΩ	24 - 75VDC
OS21A S (OEM57-51 S)	3.3A	15.8 kΩ	48 - 75VDC
OS21A P (OEM57-51 P)	6.6A	2.05 kΩ	24 - 75VDC
OS22A S (OEM57-83 S)	3.8A	12.7 kΩ	48 - 75VDC
OS22A P (OEM57-83 P)	7.5A	0.00 kΩ	24 - 75VDC
Size 34			
RS31B P (OEM83-62)*	4.4A	9.53 kΩ	24 - 75VDC
RS32B P (OEM83-93)*	5.6A	4.87 kΩ	24 - 75VDC
RS33B P (OEM83-135)*	6.9A	1.27 kΩ	24 - 75VDC

S: Series Configuration P: Parallel Configuration

*OEM83 Series motors are wired internally in parallel

Motor Current/Resistor Settings for Other Motors

If you use a non-OS or non-RS motor, carefully follow the motor manufacturer's instructions regarding motor wiring and the proper operating current. Compumotor recommends a motor inductance of between 1 mH and 10 mH, measured in series or parallel (0.2 mH – 80 mH is acceptable). The next table shows resistor values that you must use to properly set motor current when using the OEM750/OEM750X with a non-OS or non-RS Series motor. The drive can generate from 0.2 to 7.5 amps, determined by the **motor current range DIP switches** (SW3-#7 and SW3-#8).

SW3-#7 Off / #8 Off

Current (Amps*)	Resistance (Ohms)	Current (Amps*)	Resistance (Ohms)
7.5	0 Ω	4.9	7.32 kΩ
7.4	205 Ω	4.8	7.68 kΩ
7.3	412 Ω	4.7	8.06 kΩ
7.2	619 Ω	4.6	8.45 kΩ
7.1	825 Ω	4.5	8.87 kΩ
7.0	1.02 kΩ	4.4	9.53 kΩ
6.9	1.27 kΩ	4.3	10.0 kΩ
6.8	1.54 kΩ	4.2	10.5 kΩ
6.7	1.78 kΩ	4.1	10.0 kΩ
6.6	2.05 kΩ	4.0	11.5 kΩ
6.5	2.26 kΩ	3.9	12.1 kΩ
6.4	2.55 kΩ	3.8	12.7 kΩ
6.3	2.80 kΩ	3.7	13.3 kΩ
6.2	3.09 kΩ	3.6	13.7 kΩ
6.1	3.32 kΩ	3.5	14.3 kΩ
6.0	3.57 kΩ	3.4	15.0 kΩ
5.9	3.92 kΩ	3.3	15.8 kΩ
5.8	4.22 kΩ	3.2	16.5 kΩ
5.7	4.53 kΩ	3.1	17.4 kΩ
5.6	4.87 kΩ	3.0	18.2 kΩ
5.5	5.11 kΩ	2.9	19.1 kΩ
5.4	5.49 kΩ	2.8	20.0 kΩ
5.3	5.76 kΩ	2.7	20.5 kΩ
5.2	6.19 kΩ	2.6	21.5 kΩ
5.1	6.49 kΩ	2.5	22.6 kΩ
5.0	6.81 kΩ		

SW3-#7 On / #8 Off

Current (Amps*)	Resistance (Ohms)
2.5	0 Ω
2.4	619 Ω
2.3	1.27 kΩ
2.2	2.05 kΩ
2.1	2.80 kΩ
2.0	3.57 kΩ
1.9	4.53 kΩ
1.8	5.49 kΩ
1.7	6.49 kΩ
1.6	7.68 kΩ
1.5	8.87 kΩ
1.4	10.5 kΩ
1.3	12.1 kΩ
1.2	13.7 kΩ
1.1	15.8 kΩ
1.0	18.2 kΩ
0.9	20.5 kΩ
0.83	22.6 kΩ

SW3-#7 Off / #8 On

Current (Amps*)	Resistance (Ohms)	Current (Amps*)	Resistance (Ohms)
2.0	0 Ω	1.3	7.32 kΩ
1.9	787 Ω	1.2	8.87 kΩ
1.8	1.62 kΩ	1.1	10.7 kΩ
1.7	2.49 kΩ	1.0	13.0 kΩ
1.6	3.57 kΩ	0.9	15.4 kΩ
1.5	4.64 kΩ	0.8	18.2 kΩ
1.4	5.90 kΩ	0.7	21.5 kΩ

SW3-#7 On / #8 On

Current (Amps*)	Resistance (Ohms)
0.7	0 Ω
0.6	2.21 kΩ
0.5	5.36 kΩ
0.4	10.0 kΩ
0.3	16.2 kΩ
0.2	27.4 kΩ

*NOTE: Current is specified in I_{pk} , or *peak* amperes per phase. I_{pk} is related to the average current value, I_{rms} , as follows: $I_{pk} = \sqrt{2}(I_{rms})$

OEM750/750X Resistor Selection for Motor Current

- Connect a 24VDC - 75VDC power supply to **VDC+** and **VDC-**, as shown in the next drawing.

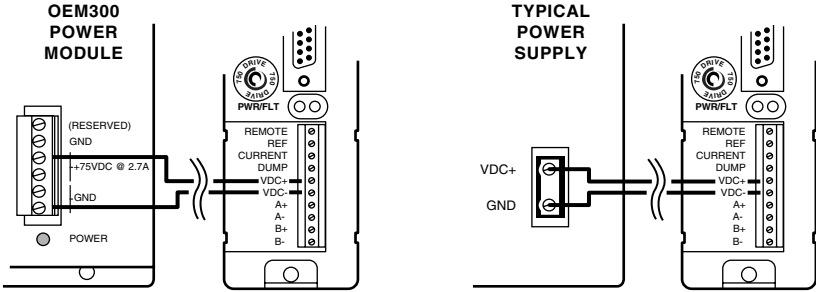

Power Supply Connections

CAUTION

Do not reverse VDC+ and VDC-. Reversing these connections can seriously damage the drive.

If you are testing an OEM750 with a separate indexer, or an OEM750X, skip Step 8 below, and proceed to one of the next two sections.

The next drawing shows the complete OEM750 test configuration with a motor and an OEM300 Power Module.

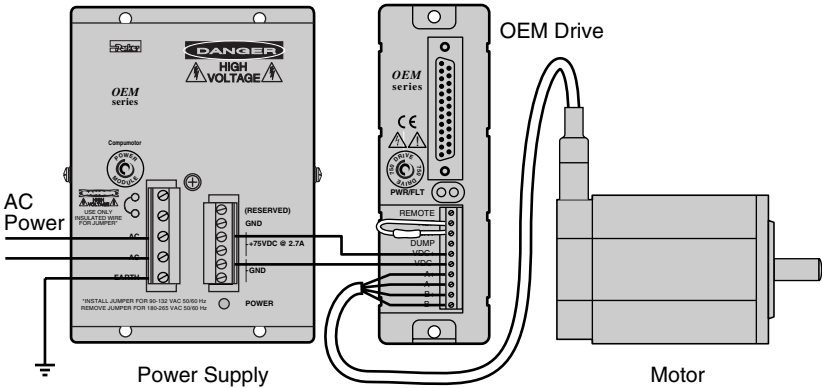

Test Configuration with OEM750

- Apply power. The drive's green **POWER** LED should be on. If the red **FAULT** LED is on, consult *Chapter 4, Troubleshooting*. After verifying that the motor moves clockwise and counterclockwise, turn off power.
 - Disconnect cables and resistor.
 - Remove cover.
 - Turn DIP SW3-#3 *on* to disable the automatic test function.
 - Replace cover.

Quick Test: OEM750 with Separate Indexer

- Complete steps 1 – 7 from the *Quick Test*, **but turn DIP SW3-#3 ON** to disable the automatic test function.
- To connect a **Compumotor indexer** to the OEM750's 25 pin D-connector, use the cable provided with the indexer. Plug the cable into the OEM750's 25 pin D-connector. No additional wiring is necessary. Refer to the indexer's user guide for specific instructions for operating the Compumotor indexer.
To connect a **non-Compumotor indexer**, connect step and direction outputs from the indexer to the OEM750's 25 pin D-connector, according to the next drawing.

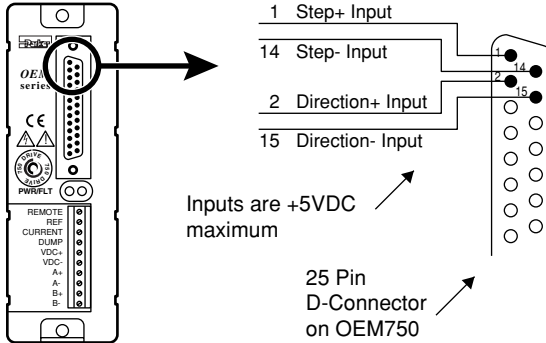

Test Configuration – OEM750 Step and Direction Inputs

The next drawing shows the test configuration with a separate indexer, a motor, and an OEM300 Power Module.

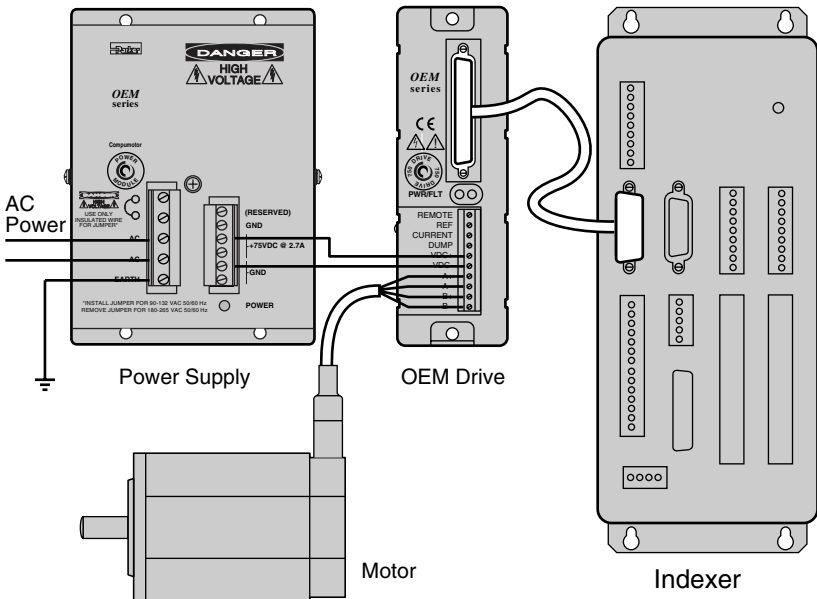

Test Configuration with OEM750 and Separate Indexer

3. Apply power. The OEM750's green power LED should be on. If the red **FAULT** LED is on, consult *Chapter 4, Troubleshooting*.

This test assumes that your indexer's motor resolution is set to 25,000 steps/rev. This is the default motor resolution setting for the OEM750.

4. Using the indexer, send step pulses to the drive that will rotate the motor one **CW** revolution (25,000 step pulses) at 1 rps (25,000 steps per second).
5. Using the indexer, send step pulses to the drive that will rotate the motor one **CCW** revolution at 1 rps. The drive's default direction is CCW (i.e., if the direction input is not activated, the motor will rotate CCW—if the direction input is activated, the motor will rotate CW). If the motor does not rotate in the desired direction, remove drive power and reverse the direction sense for your system by reversing the motor leads going to the A+ and A- terminals.

WARNING

Never connect or disconnect any component to or from the drive with power applied. System damage or personal injury may occur.

6. After verifying that the motor moves CW and CCW, turn off power.

Quick Test: OEM750X

1. Complete steps 1- 7 from the OEM750 Quick Test, **but turn DIP SW3-#3 ON** to disable the automatic test function.
2. Connect the OEM750X to an RS-232C communications device (i.e., computer, PLC, etc.). The OEM750X's communication parameters are listed below:
 - Baud Rate: 9600
 - Data Bits: 8
 - Stop Bit: 1
 - Parity: None

Reference XON/OFF command for handshaking support. Terminals should be set for full duplex mode. The next drawing shows pins to use for transmit, receive, and ground.

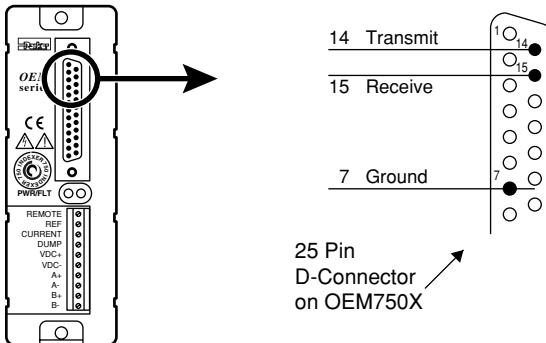

Test Configuration – OEM750X RS-232C Connections

CAUTION

RS-232C signals are not on pins 2, 3, and 7 of the 25 pin D-connector.

The next drawing shows the test configuration with an OEM750X and an RS-232C terminal.

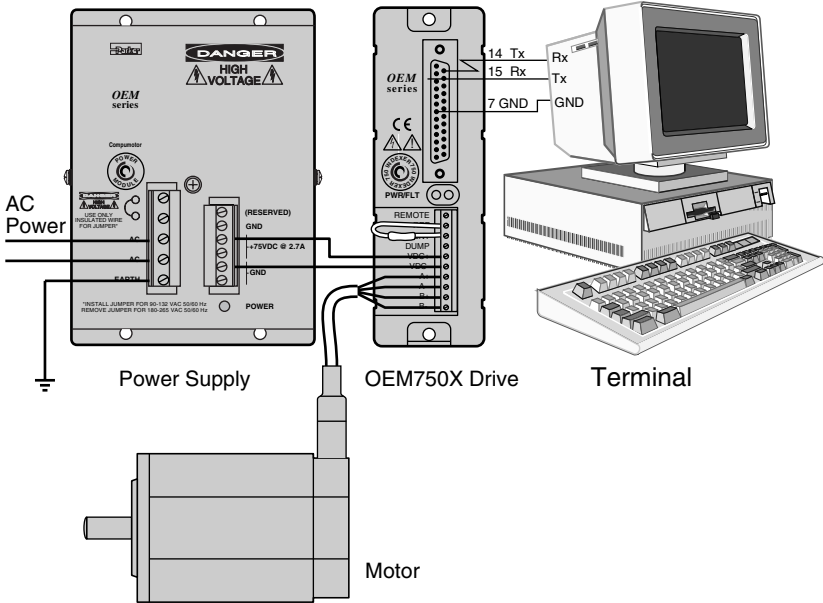
*Test Configuration with OEM750X*

3. Apply power. The OEM750X's green power LED should be on. If the red **FAULT** LED is on, consult *Chapter 4, Troubleshooting*.

This test assumes that your indexer's motor resolution is set to 25,000 steps/rev. This is the default motor resolution setting for the OEM750X.

Note: The drive and indexer resolutions are set independently. Verify that the four drive resolution dip switches (SW2-#2 – SW2-#5) are all ON for 25,000 steps/rev. You must cycle power for DiP switch changes to take effect.

4. Enter and run the following command sequence to test the system.

<u>Command</u>	<u>Description</u>
MN	Sets unit to Normal mode
LD3	Disables CW & CCW Limits
A10	Set acceleration to 10 rps ²
V10	Set velocity to 10 rps
D25000	Set move distance to 1 CW revolution
G	Initiate move (Go)
H	Reverse move direction (CCW)
G	Initiate move (Go)

5. After verifying that the motor moves CW and CCW, turn off power.

DIP Switch Functions

Configure the OEM750/OEM750X's DIP switches for your motor and application. See *Quick Test* for switch location. The following table and descriptions summarize switch settings.

OEM750 DIP SETTINGS

on ↑

Factory Default Configuration Shown →

OZ

OZ

		SW 2					SW 3																																
Anti-resonance	1																																						
	<table border="1" style="width: 100%; border-collapse: collapse;"> <tr> <td style="text-align: center;">Anti-res. Disabled</td> <td style="text-align: center;">off</td> <td colspan="11"></td> </tr> <tr> <td style="text-align: center;">Default Anti-res. Enabled</td> <td style="text-align: center;">on</td> <td colspan="11"></td> </tr> </table>	Anti-res. Disabled	off												Default Anti-res. Enabled	on																							
Anti-res. Disabled	off																																						
Default Anti-res. Enabled	on																																						
Resolution (Steps per Revolution)			2	3	4	5																																	
			50,800	on	on	on	off																																
			50,000	on	on	off	on																																
			36,000	on	on	off	off																																
			25,600	on	off	on	on																																
			25,400	on	off	on	off																																
	Default Setting		25,000	on	on	on	on																																
			21,600	on	off	off	on																																
			20,000	on	off	off	off																																
			18,000	off	on	on	on																																
			12,800	off	on	on	off																																
			10,000	off	on	off	on																																
			5,000	off	on	off	off																																
			2,000	off	off	on	on																																
			1,000	off	off	on	off																																
		400	off	off	off	on																																	
		200	off	off	off	off																																	
Waveform			Pure Sine			off	off	on																															
			-2% 3rd Harmonic			off	on	off																															
			-4% 3rd Harmonic			off	off	off																															
	Default Setting		-4% 3rd Harmonic			on	on	on																															
			-4% 3rd Harmonic			off	on	on																															
			-6% 3rd Harmonic			on	off	off																															
			-8% 3rd Harmonic			on	off	on																															
		-10% 3rd Harmonic			on	on	off																																
Automatic Standby	Default Setting		Full Current		on	on																																	
			75% Current		off	on																																	
			50% Current		on	off																																	
			25% Current		off	off																																	
					1	2																																	
Automatic Test	Default Setting		Automatic Test Disabled		on																																		
			Automatic Test Enabled		off																																		
Current Loop Gain					4	5	6																																
					1	off	off	off																															
					2	on	off	off																															
					4	off	on	off																															
	Default Setting				8	on	on	off																															
					16	off	off	on																															
					32	on	off	on																															
					64	off	on	on																															
				64	on	on	on																																
Current Range	Default Setting		2.5 – 7.5 amps		off	off																																	
			0.83 – 2.5 amps		on	off																																	
			0.7 – 2.0 amps		off	on																																	
			0.2 – 0.7 amps		on	on																																	
					7	8																																	

Anti-Resonance

SW2-#1 should be *on* for the anti-resonance circuit to be enabled. Normally, you will want anti-resonance to be enabled; therefore, this switch should be on. If you are using pulse placement for positioning, you may need to disable anti-resonance. You can disable anti-resonance by turning SW2-#1 *off*.

Drive Resolution

Set DIP switches SW2-#2 — SW2-#5 for drive resolution. There are sixteen settings, which range from 200 to 50,800 steps per revolution. The default setting is 25,000 steps per revolution.

Waveform

Set SW2-#6 — SW2-#8 to select a current waveform. There are six choices: one is a pure sine wave; the others reduce the current waveform's 3rd harmonic by 2%, 4%, 6%, 8% and 10%. In most cases, the default setting (*all three switches on = -4% 3rd harmonic*) provides the best performance. For further information about selecting a waveform, see *Adjusting Motor Current Waveforms* in *Chapter 3*.

Automatic Standby

SW3-#1 and SW3-#2 should be *on* if you do not use automatic standby (this is the default position). If you use an indexer and encoder for position maintenance, we recommend that you do not use automatic standby.

The automatic standby function allows the motor to cool when it is not commanded to move. Automatic standby reduces motor current (by 25%, 50%, or 75%) if the drive does not receive a step pulse for one second. Full current is restored upon the first step pulse that the drive receives. ***Be aware that reduced current results in reduced holding torque.***

Automatic Test

Set SW3-#3 to the *off* position to select the automatic test function. The automatic test turns the motor shaft slightly less than six revolutions in an alternating mode at 1 rps. Automatic standby and drive resolution settings are disabled when you use the automatic test.

The default position for SW3-#3 is *on*, which disables the automatic test function.

Current Loop Gain

Set the current loop gain DIP switches to maximize your system's performance.

Your system has a gain. Its value is determined by three parameters: power supply voltage, motor inductance, and current loop gain. If you increase power supply voltage or decrease motor inductance, the system will have more gain. Conversely, if you decrease power supply voltage or increase motor inductance, the system will have less gain. Too much gain may cause oscillations, resulting in audible noise and excess motor heating.

In most applications, power supply voltage and motor inductance are determined by the application's requirements. To set your system's gain at its optimum value, you can adjust the third parameter—the current loop—by setting three *current loop gain* DIP switches. There are seven loop gain settings, which range from 1 to 64, as shown in the *DIP Settings* table on Page 16.

Use the next equation to determine your *ideal* loop gain:

$$\text{Current Loop Gain} = (\text{Motor inductance} / \text{Power Supply Voltage}) * 364,000$$

Note: inductance is in henrys; supply voltage is in VDC. For inductance, use small signal inductance value measured using an ordinary inductance bridge or meter. Large signal inductance is found by measuring the actual generator AC flux linkage and generator short circuit current under dynamic conditions.

$$\text{Small signal inductance} * 1.5 \approx \text{large signal inductance}$$

To determine your *actual* loop gain, choose a value from the *DIP Settings* table that is less than or equal to the ideal value.

Example:

An RS33B motor is used with a 75VDC power supply. The ideal current loop gain is:

$$\text{Current Loop Gain} = (0.0022 \text{ H} / 75\text{VDC}) * 364,000 = 10.7$$

From the DIP switch table, select a current loop gain of 8, because 8 is less than 10.7

The next table shows settings for Compumotor motors.

Motor Size		Inductance	Loop Gain@	Loop Gain@	Loop Gain@
Size 23	Connection	(small signal)	24vdc	48vdc	75vdc
OS2HA (OEM57-40)	Series	1.6 mH	16	8	8
OS2HA (OEM57-40)	Parallel	400 μH	4	4	2
OS21A (OEM57-51)	Series	1.7 mH	16	8	8
OS21A (OEM57-51)	Parallel	425 μH	4	2	2
OS22A (OEM57-83)	Series	2.6 mH	32	16	8

OS22A (OEM57-83)	Parallel	650 μ H	8	4	2	
Size 34						
RS31B (OEM83-62)*	Parallel	2.9 mH (2.2 mH)	32	16	8	
RS32B (OEM83-93)*	Parallel	2.9 mH (2.2 mH)	32	16	8	
RS33B (OEM83-135)*	Parallel	2.4 mH (2.2 mH)	32	16	8	

*OEM83 motors are wired internally in parallel

Current Range

Set SW3-#7 and SW3-#8 to select a range for motor current settings. In Step 6 of the Quick Test you installed a resistor that determines motor current. Be sure that SW3-#7 and SW3-#8 are set to the proper current range for the resistor you installed.

OEM750 Inputs and Outputs

The next figure shows internal connections for the OEM750. See the following section for OEM750X internal connections.

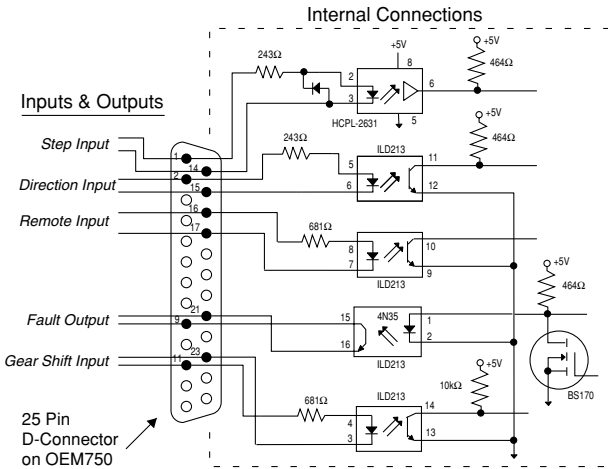

Inputs and Outputs – OEM750 Schematic

STEP INPUT

For every step pulse it receives on its step input, the drive will commutate the motor to increment rotor position. To send a step pulse to the drive, apply a positive voltage to STEP+ with respect to STEP-. The drive registers the pulse on the rising edge.

The step input is optically isolated. Driving the step input

differentially will provide the best noise immunity. Your input driver must provide a minimum of 6.5 mA—*approximately 3.5 VDC*. With no external current limiting resistor, the current is controlled by the applied voltage. This is due to a fixed voltage drop of 1.7VDC on the opto LED and the internal series resistor (243Ω). Increased voltage will result in increased current.

Step Pulse Requirements

Operate the step pulse input within the following guidelines:

- 200 nanosecond pulse – minimum
- 40% – 60% duty cycle (2 MHz maximum pulse rate)

DIRECTION INPUT SIGNAL SPECIFICATION

While a positive voltage is applied to DIR+ with respect to DIR-, the drive will commutate the motor in the clockwise (positive) direction as it receives step pulses on its step input.

While zero voltage (or a negative voltage) is applied to DIR+ with respect to DIR-, the drive will commutate the motor in the counterclockwise (negative) direction as it receives step pulses.

The input is optically isolated. It may be differentially driven.

CAUTION

Reverse voltage in excess of 6VDC may damage this device.

Your input driver must provide a minimum of 8mA at 3.5VDC to ensure proper operation. With no external current limiting resistor, the current is controlled by the applied voltage. This is due to a fixed voltage drop of 1.5VDC on the opto LED and the internal series resistor (243Ω).

Direction Change

The direction may change polarity coincident with the last step pulse. The direction input must be stable for at least 200 microseconds before the drive receives the first pulse.

REMOTE INPUT

The remote input is an optically isolated input. It requires a minimum of 3.5 mA—*approximately 4.0 VDC*—to ensure

proper system operation. This input may be differentially driven.

CAUTION

Reverse voltage in excess of 6VDC may damage this device.

With no external current limiting resistor, the current is controlled by the applied voltage. This is due to a fixed voltage drop of 1.5VDC on the opto LED and the internal series resistor (681Ω).

This input allows you to reduce current to a motor from a remote location. This is accomplished by changing the current select resistor via the remote input. When the remote input is enabled, the open collector transistor internally connected to the REMOTE screw terminal will conduct to ground.

To reduce motor current to zero, short the CURRENT and REMOTE terminals together (with a wire).

You can also reduce motor current by a percentage if you short CURRENT and REMOTE with the appropriate resistor (R_{REMOTE}). To calculate R_{REMOTE} , first select R_C , the resistor associated with your normal operating current (see resistor selection tables in the *Quick Test*). Next select R_S , the resistor in the same section of the table that is associated with your desired standby current. Then use the following equation to find R_{REMOTE} .

$$R_{\text{REMOTE}} = -13,300 (3750 + R_C) / (R_C - R_S)$$

R_C = Resistor associated with the operating current

R_S = Resistor associated with the desired standby current

FAULT OUTPUT

The fault output is an open-collector, open emitter output from an ILQ2 OPTO isolator. The output transistor will conduct when the drive is functioning properly. The transistor will not conduct when any of the following conditions exist.

- No power is applied to the drive
- There is insufficient voltage (<24VDC)

- The driver detects a motor fault
- The remote input is enabled

The fault output has the following electrical characteristics (OEM750):

- $V_{CE} = 70\text{VDC}$
- $V_{CESAT} = 0.3\text{VDC}$
- Collector Current = 10 mA maximum
- Dissipation = 55 mW maximum

GEAR SHIFT INPUT

The gear shift input is an optically isolated input. The GS+ terminal (pin 11) is connected to the anode of the OPTO lead via a 681Ω current limiting resistor. The GS- terminal (pin 12) is connected to the cathode of the OPTO lead. The OPTO requires a minimum of 3.5 mA—*approximately 4.0 VDC*—to ensure proper system operation. This input may be differentially driven.

CAUTION

Reverse voltage in excess of 6VDC may damage this device.

With no external current limiting resistor, the current is controlled by the applied voltage. This is due to a fixed voltage drop of 1.5VDC on the opto LED and the internal series resistor (681Ω).

The gear shift function allows a user with a limited frequency generator to achieve higher velocities while using high resolution settings. The drive multiplies each step pulse it receives by a factor of 8. This function may be invoked *on-the-fly*; however, to prevent stalling and to keep track of motor position, it should only be invoked when the motor is not moving.

Using the gear shift function is equivalent to changing drive resolution, and may have an adverse effect on low speed performance (smoothness). We recommend that you do not use the gear shift with resolution settings less than 10,000 steps per revolution.

OEM750X Inputs and Outputs

The next drawing shows the pin-out for the OEM750X.

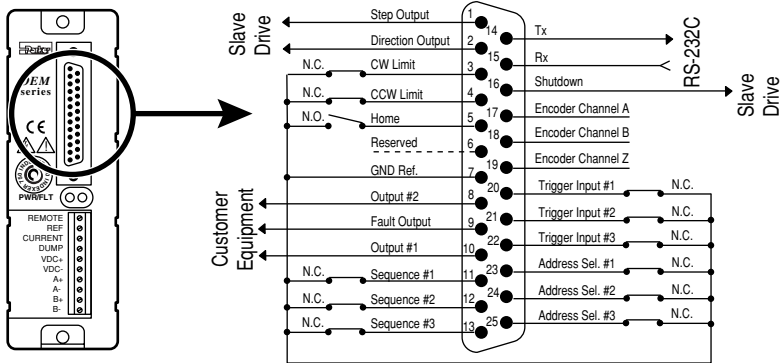

Inputs and Outputs – OEM750X Schematic

Several functions—triggers, limits, sequence select inputs, home, and address inputs—require a ground reference. For these functions, use pin 7 on the 25 pin D-connector for the ground. Do not use the power supply ground VDC-. Pin 7 and VDC- are internally connected, but your system will be more immune to electrical noise if you use pin 7.

CAUTION

I/O is not OPTO isolated. Use Pin 7 for a ground reference. Do not use VDC- for a ground reference.

STEP (PIN 1) & DIRECTION (PIN 2) OUTPUTS

The OEM750X produces step and direction outputs that are identical to its own internal step and direction signals. These outputs can be used to slave to another drive or to monitor the OEM750X's position and velocity. The direction output's default state is logic high. The step output's default state is a high, pulsing low output. The next figure represents a typical configuration of this output.

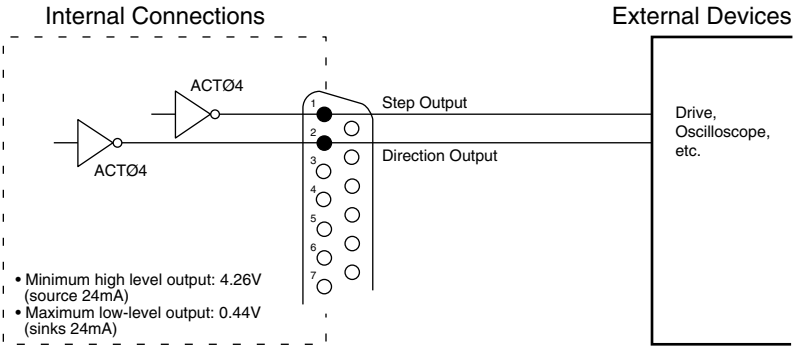

Step and Direction Outputs

CW (PIN 3) & CCW (PIN 4) LIMIT INPUTS

The OEM750X has two dedicated hardware end-of-travel limits—clockwise (CW) and counterclockwise (CCW). When you apply power to the OEM750X, these inputs are enabled—the default active state is *high*. To test the OEM750X without connecting the CW and CCW limits, you must disable the limits with the **LD3** command. You can use the Limit Switch Status Report (**RA**) and Input Status (**IS**) commands to monitor the limits' status, and the **OSA** command to change the active level of the inputs. The figure represents a typical configuration of these inputs.

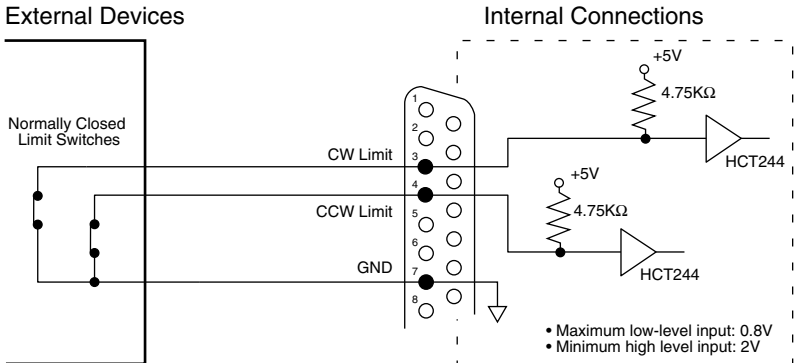

Limit Inputs

HOME POSITION INPUT (PIN 5)

The OEM750X has one dedicated home input. The home input allows you to establish a home reference input. This input is not active during power-up—its default active state is *low*. Refer to the Go Home (**GH**) command for more information on setting up and using this function. The figure represents a typical configuration of this input. (Refer to the **OSC** command, which changes the active level of the home input, and the **GH** command.)

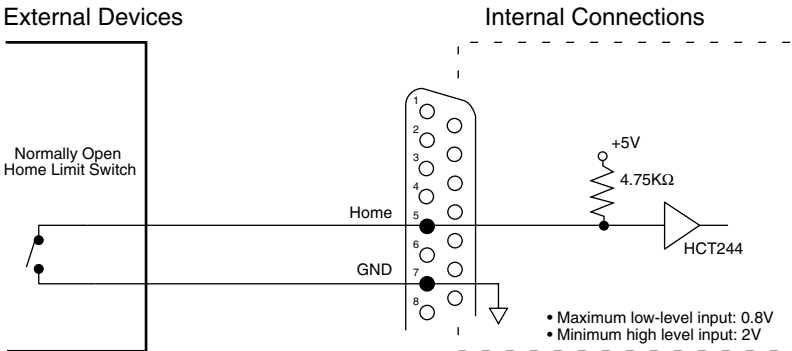

Home Input

OUTPUT #1 (PIN 10) AND OUTPUT #2 (PIN 8)

The OEM750X has two dedicated programmable outputs. They may be used to signal peripheral devices upon the start or completion of a move. The default state for outputs #1 and #2 is logic low. The outputs are internally pulled up to 5VDC when active. The figure represents a typical configuration of these outputs. (Refer to the **O** command.)

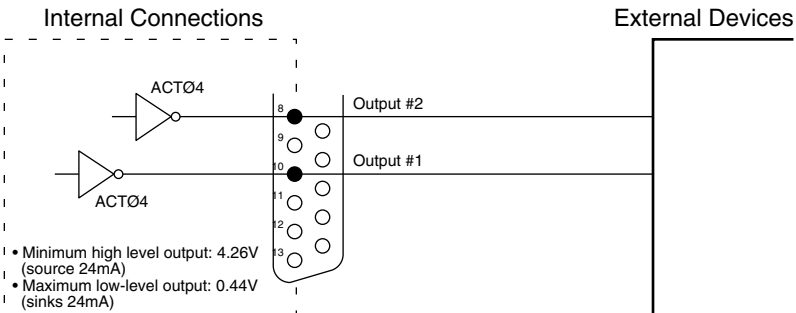

Output #1 and Output #2

DEDICATED FAULT OUTPUT (PIN 9)

The OEM750X has one dedicated fault output. This output may be used to signal peripheral devices if an OEM750X failure occurs. The Fault output's default state is logic high. If a fault occurs, internal circuitry energizes the transistor's base, pulling the output low. The figure represents a typical configuration of this output.

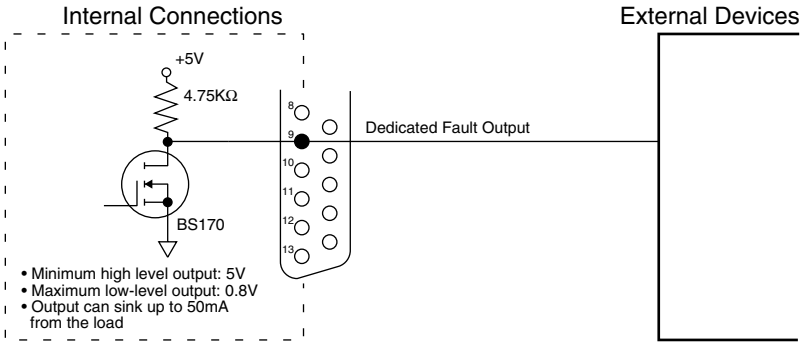

Dedicated Fault Output

SEQUENCE INPUTS #1 – #3 (PINS 11 – 13)

The OEM750X has three dedicated sequence inputs that allow you to control seven different sequences. The default active state is *high*. You must use the **X** commands (particularly the **XP** command) to configure these inputs. Sequence #0 is not a valid sequence.

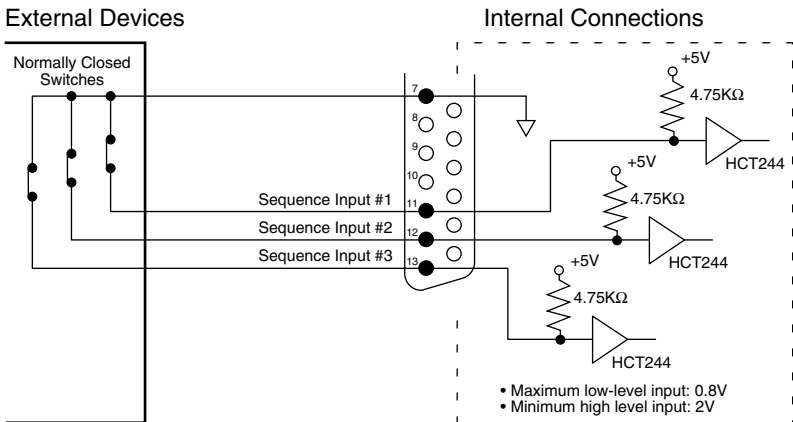

Sequence Inputs

Sequences are executed remotely by using one of the following logic patterns. (1 represents a +5V signal, Ø represents a 0V signal.)

Sequence #	Ø	1	2	3	4	5	6	7
SEQ Input #1	Ø	1	Ø	1	Ø	1	Ø	1
SEQ Input #2	Ø	Ø	1	1	Ø	Ø	1	1
SEQ Input #3	Ø	Ø	Ø	Ø	1	1	1	1

The figure represents a typical configuration of these outputs.

RS-232C—Tx (PIN 14), Rx (PIN 15), AND GROUND (PIN 7)

The OEM750X uses RS-232C as its communication medium. A typical three-wire (Receive, Transmit, and Signal Ground) configuration is used. The figure represents a typical RS-232C configuration.

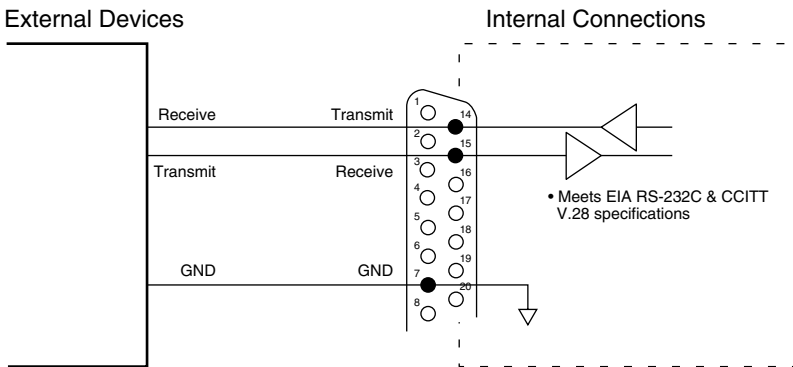

RS-232C Input and Output

SHUTDOWN OUTPUT (PIN 16)

The OEM750X produces a shutdown output that is identical to its own internal signal. This output may be used to slave to another drive or to monitor the OEM750X. The shutdown output's default state is logic high. The figure represents a typical configuration of this output. (Refer to the **ST** command.)

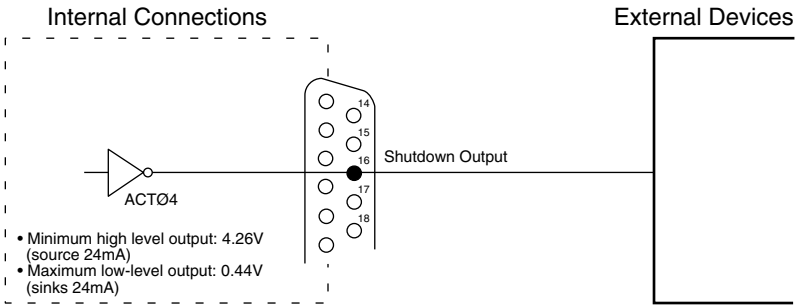

Shutdown Output

CLOSED LOOP OPERATION

Closed loop moves require an external encoder to provide position correction signals. Motor position may be adjusted to reach the desired position. To implement the closed loop functions, you must connect a single-ended, incremental, optical encoder to the OEM750X. You can then use the **FS** commands, which add the functions below:

- Encoder referenced positioning
- Encoder position servoing
- Motor stall detection
- Higher accuracy homing function

ENCODER INPUTS A, B, Z (PINS 17–19)

The OEM750X has three dedicated inputs for use with a single ended incremental encoder. These inputs, in conjunction with the **FS** commands, determine encoder functionality. Reference the encoder ground to pin 7 of the OEM750X.

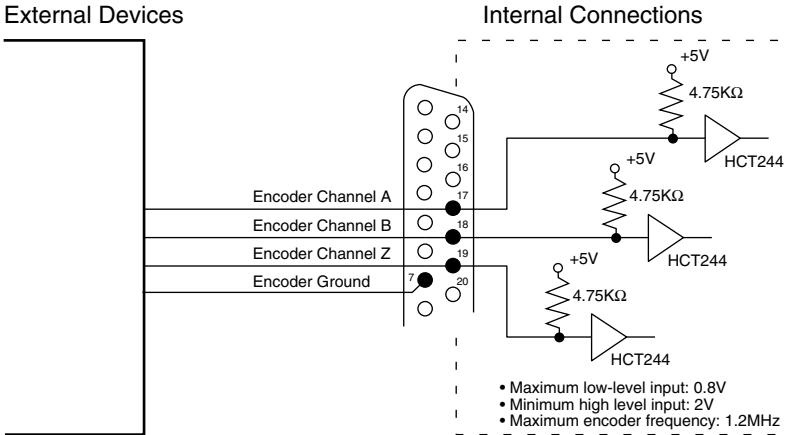

Encoder Inputs

TRIGGER INPUTS #1 – #3 (PINS 20 – 22)

The OEM750X has three dedicated trigger inputs. These inputs are pulled up internally. They can be active high or active low, depending on how you configure them with the Trigger (**TR**) command. The figure represents a typical configuration of these inputs.

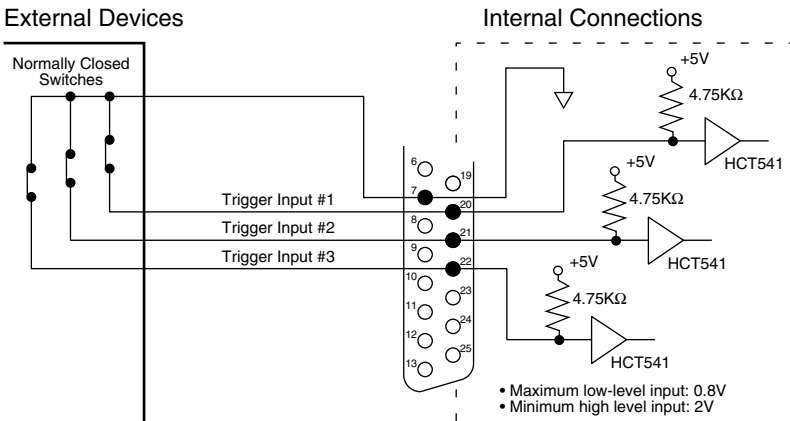

Trigger Inputs

ADDRESS INPUTS #1 – #3 (PINS 23 – 25)

The OEM750X has three dedicated address inputs that allow you to specify a unique address for each OEM750X in your configuration. Their default active state is *high*.

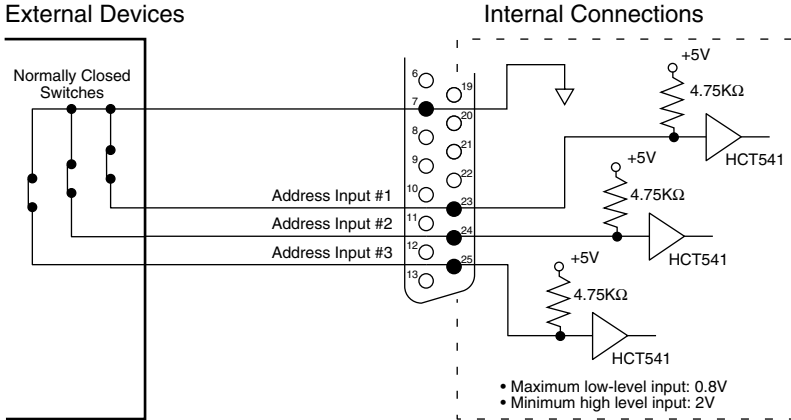

Address Inputs

Units may be assigned a valid address from 1 to 8. Each unit in the configuration must have a unique address. The default address is 8 (all three inputs are internally pulled up). The address inputs are read only during power-up and when Restart (**Z**) commands are issued. Use the matrix below to assign unique address values. (Refer to the # command for more information.)

Address #	1	2	3	3	5	6	7	8
Address #1	Ø	1	Ø	1	Ø	1	Ø	1
Address #2	Ø	Ø	1	1	Ø	Ø	1	1
Address #3	Ø	Ø	Ø	Ø	1	1	1	1

DAISY CHAINING

You may daisy chain up to 8 OEM750Xs. Individual drive addresses are set with the address inputs (pins 23 – 25 on the 25 pin D-connector). You should establish a unique device address for each OEM750X. When daisy chained, the units may be addressed individually or simultaneously. Refer to the next figure for OEM750X daisy chain wiring.

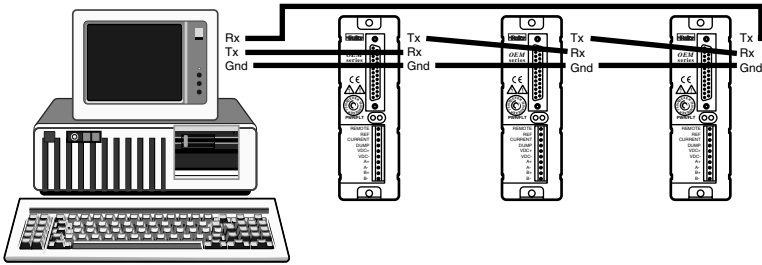

Daisy Chain Configuration

Commands prefixed with a device address control only the drive specified. Commands without a device address control all drives on the daisy chain. The general rule is: *Any command that causes the drive to transmit information from the RS-232C port (such as a status or report command), must be prefixed with a device address.* This prevents daisy chained drives from all transmitting at the same time.

Attach device identifiers to the front of the command. The Go (**G**) command instructs all drives on the daisy chain to go, while **1G** tells only drive #1 to go.

When you use a single communications port to control more than one OEM750X, all drives in a daisy chain receive and echo the same commands. Each drive executes these commands, unless this command is preceded with an address that differs from the drives' addresses on the daisy chain. This becomes critical if you instruct any drive to transmit information. To prevent all of the drives on the line from responding to a command, you must precede the command with the device address of the designated drive. No OEM750X executes a drive-specific command unless the drive number specified with the command matches the OEM750X's drive number. Drive-specific commands include both buffered and immediate commands.

Choosing a Power Supply

The next table contains power ratings to help you choose a power supply. Combinations of motors and current levels other than those shown may result in power values that are not recommended.

Motor Size (@75VDC)	Peak	Motor Heat +			Supply Total**
		Motor Current	Avg. Shaft Power	Drive Heat	
Size 23					
OS2HA S (OEM57-40 S)		2.65A	56 Watts	9 Watts	65 Watts
OS2HA P (OEM57-40 P)		5.3A	56 Watts	19 Watts	75 Watts
OS21A S (OEM57-51 S)	3.3A		75 Watts	11 Watts	86 Watts
OS21A P (OEM57-51 P)		6.6A	75 Watts	25 Watts	100 Watts
OS22A S (OEM57-83 S)		3.8A	86 Watts	13 Watts	99 Watts
OS22A P (OEM57-83 P)		7.5A	86 Watts	31 Watts	117 Watts
Size 34					
RS31B P (OEM83-62)*		4.4A	113 Watts	15 Watts	128 Watts
RS32B P (OEM83-93)*		5.6A	133 Watts	20 Watts	153 Watts
RS33B P (OEM83-135)*		6.9A	155 Watts	27 Watts	182 Watts

S: Series Configuration P: Parallel Configuration

*OEM83 motors are wired internally in parallel

** User must supply this level of wattage

Use the following equation to determine drive heat.

$$\text{Drive Heat (Watts)} = (0.31) (I_M^2) + (1.13 I_M) + 3 \quad I_M = \text{Motor Current}$$

Conversions

- To convert watts to horsepower, **divide by 746**
- To convert watts to BTU/hour, **multiply by 3.413**
- To convert watts to BTU/minute, **multiply by 0.0569**

SERIES AND PARALLEL WIRING

Compumotor OS motors may be configured in parallel or series. Refer to the *Quick Test* section at the beginning of this chapter for wiring instructions.

MOTOR TYPE

Compumotor's OS and RS Series motors are custom-made for use with the OEM750/OEM750X. These motors are not available as a standard model from any other manufacturer. They are designed for low loss at rest and at high speed.

Motors in the same frame size from other manufacturers may sustain considerably higher iron losses than an OEM750/OEM750X motor. OS and RS motors are wound to render inductances within a range suitable for OEM Series products. If you do not use an OS or RS motor, you should consult Compumotor's Applications Engineering Department for assistance (800-358-9070).

The OEM750/OEM750X is designed to run 2-phase PM step motors only. Do not use variable reluctance or DC motors.

CURRENT (AMPS)

We have chosen motor current values (shown earlier) so the motors can produce the highest possible torque, while maintaining smoothness. Higher currents will produce higher static torque; but, the motor will run roughly and may overheat. Do not run the parallel rated current into a motor that is wired in series—it will destroy the motor's windings.

POWER DUMP

This drive has built-in power dump circuitry to monitor power supply surges caused by a regenerative load. The power dump circuit is used in conjunction with an externally mounted power resistor. You must connect the power resistor from the **VDC+** terminal to the **DUMP** terminal. The circuitry effectively closes a “switch” to ground when the power supply voltage exceeds 85VDC. This “switch” terminal is connected at the screw terminal labeled **DUMP**. The power dump feature dissipates the energy created by a regenerative load (100 joules maximum). ***The power dump is not designed to protect the drive from overvoltage caused by a poorly regulated or faulty power supply.*** A 35 ohm, 10 watt power resistor (such as a Dale RH-10) is the recommended power dump resistor. You must heat sink the resistor for it to meet its rated wattage.

CAUTION

Never allow the voltage supplied by the power supply to exceed 80VDC. Damage to the power dump resistor may result.

Mounting

The OEM750/OEM750X is designed for a *minimum area* mounting configuration. An optional heatsink can be used for a *minimum depth* mounting configuration.

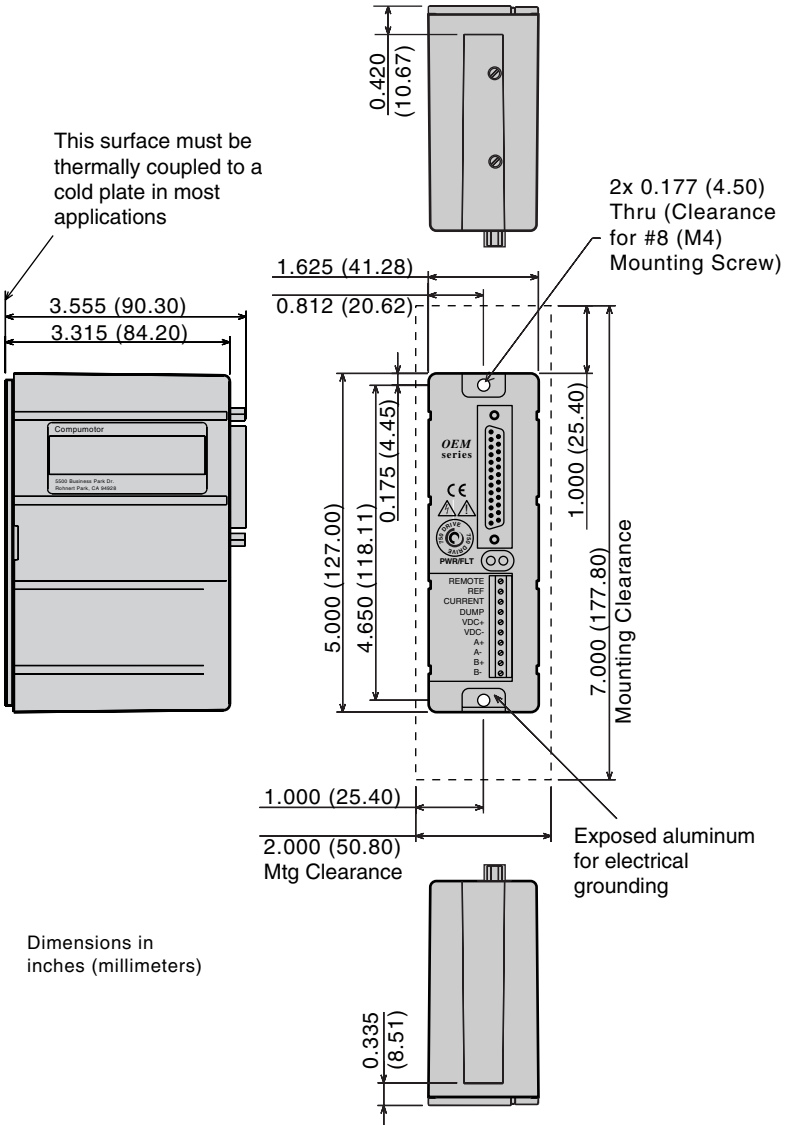

OEM750/OEM750X Dimensions

PANEL LAYOUT

If you mount the OEM750/OEM750X in an enclosure, observe the following guidelines:

- Do not mount large, heat-producing equipment directly beneath the OEM750 or OEM750X.
- Do not mount the OEM750 directly below an indexer or other heat sensitive equipment (the drive produces more heat than an indexer).
- Fan cooling may be necessary.

Refer to the instructions and diagrams in this section for specific mounting information about your configuration.

Mounting Without a Heatsink

If you use the OEM750/OEM750X without a heatsink, the next drawing shows the minimum recommended panel layout. Additional space may be required if heat dissipation is an issue.

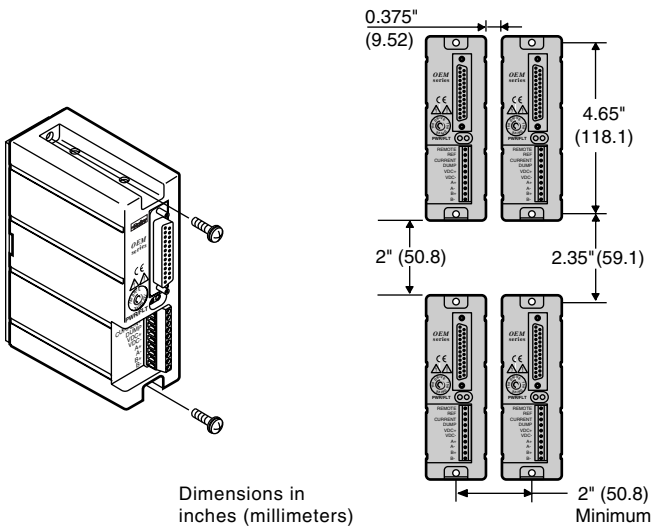

Panel Layout (Without a Heatsink)

The OEM uses a heatplate design to dissipate heat. The drive should never be operated for more than a few minutes without properly mounting the drive to an adequate thermal heatsink.

The next drawing shows how much heat is generated by the OEM750/OEM750X. This heat must be dissipated by the mounting surface.

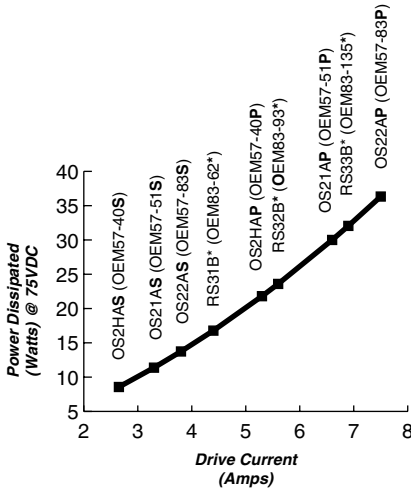

S—Series Configuration
P—Parallel Configuration
*—operate 34 size motors in parallel only

Power Dissipation

The total thermal dissipation in the OEM750/OEM750X is almost constant, regardless of whether the motor is stationary or in motion. The current range DIP switches and the resistor that sets motor current determine the motor phase currents that cause the power losses shown in the figure above.

Overtemperature Protection

The OEM750/OEM750X is overtemperature protected. The drive is designed to operate in a maximum 50°C (122°F) ambient with a maximum heatplate temperature of 55°C (131°F). **Do not allow the drive's heatplate temperature to exceed 55°C.** The drive will fault if its heatplate temperature exceeds 55°C.

To measure drive temperature under operating conditions, position a thermal probe on the left edge of the heatplate, approximately 1.5 inches (38 mm) from the top of the drive, as shown in the next drawing.

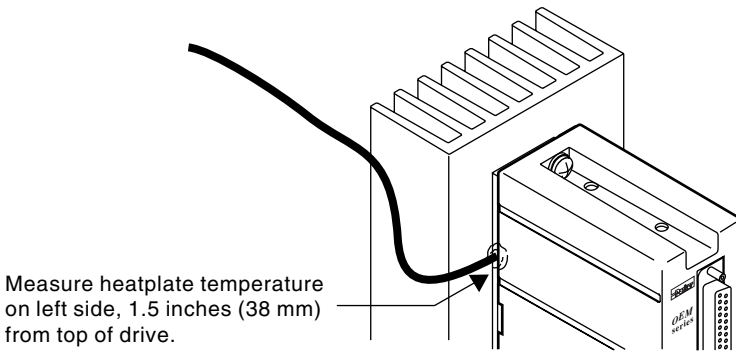

Measure heatplate temperature on left side, 1.5 inches (38 mm) from top of drive.

Heatplate Temperature Measurement

To ensure that the over-temperature protection does not unexpectedly shut down the drive, mount the drive to a suitable heat-dissipating surface. If you operate the drive in high ambient temperatures—greater than 40°C (104°F)—ensure there is unobstructed airflow over the drive.

Do not use a star washer between the back of the drive's heatplate and the mounting surface. The mounting surface must be flat. Use thermal grease or thermal pads to facilitate heat transfer from the drive's heatplate to your mounting surface.

Two types of optional heatsinks can be used for applications that do not have an adequate mounting surface.

Mounting With OEM-HS1 Heatsink

The small heatsink (OEM-HS1) may be purchased as an option. It is intended to be used with a current setting up to 5A peak in still air, at an ambient temperature of 25°C (77°F). If the drive is mounted in ambient temperatures hotter than 25°C, active cooling (forced air) will be required to maintain the heatplate temperature below 55°C (131°F).

Mount the OEM750/OEM750X to the OEM-HS1 heatsink with two #8-32 screws. (A heatsink with holes tapped for metric screws is available. Its part number is OEM-HS1-M4. Consult your Compumotor sales guide for more information.)

Use a *star washer* on the bottom screw to ensure proper electrical grounding. To facilitate heat transfer, use thermal grease or a thermal pad between the drive and the heatsink. Secure the drive and heatsink to your mounting surface with two #8 screws.

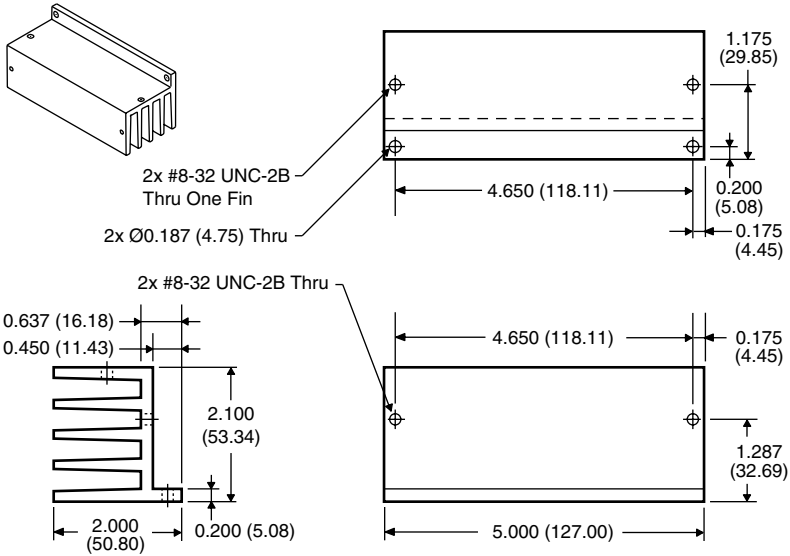

OEM-HS1 Dimensions

You can mount the drive in two different configurations with the OEM-HS1. One is a *minimum area* configuration—it uses the least amount of panel area. The other is a *minimum depth* configuration.

Panel layout for minimum area is shown in the next figure.

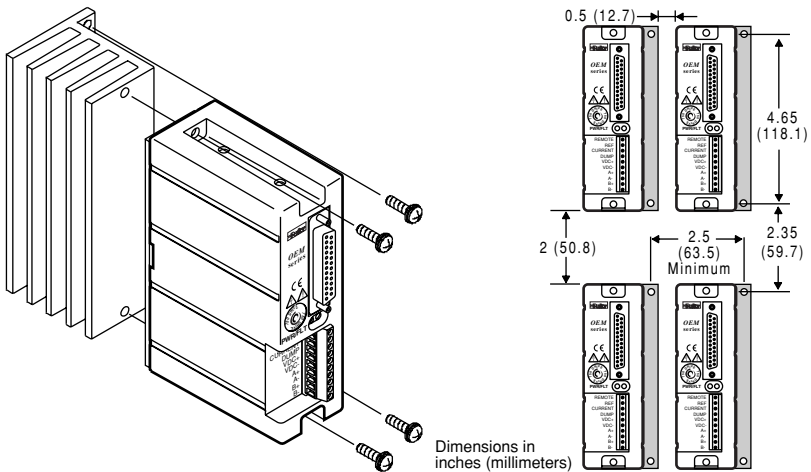

OEM-HS1 Minimum Area Panel Layout

Panel layout for minimum depth is shown in the next figure.

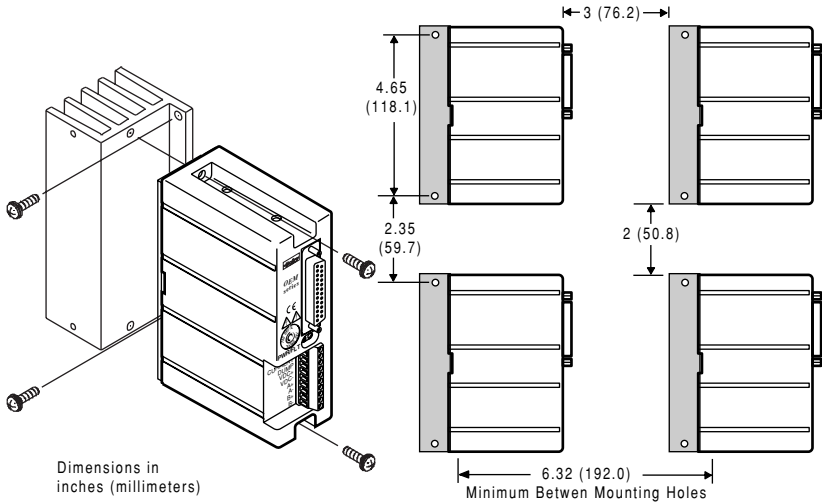

OEM-HS1 Minimum Depth Panel Layout

Mounting With OEM-HS2 Heatsink

The large heatsink (OEM-HS2) may be purchased as an option. It is intended to be used with a current setting up to the drive's maximum of 7.5A in still air, at an ambient temperature of 25°C (77°F). If the drive is mounted in ambient temperatures hotter than 25°C, active cooling (forced air) will be required to maintain the heatplate temperature below 55°C (131°F).

Mount the OEM750/OEM750X to the OEM-HS2 heatsink with two #8-32 screws. (A heatsink with holes tapped for metric screws is available. Its part number is OEM-HS2-M4. Consult your Compumotor sales guide for more information.)

Use a star washer on the bottom screw to ensure proper electrical grounding. To facilitate heat transfer, use thermal grease or a thermal pad between the drive and the heatsink.

Secure the drive and heatsink to your mounting surface with two #8 screws.

The next two drawings show OEM-HS2 dimensions, and panel layout dimensions.

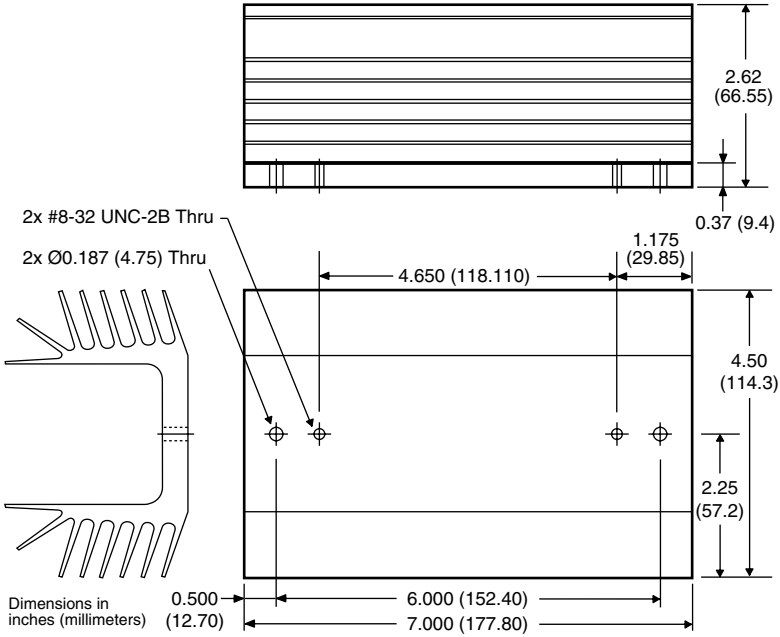

OEM-HS2 Dimensions

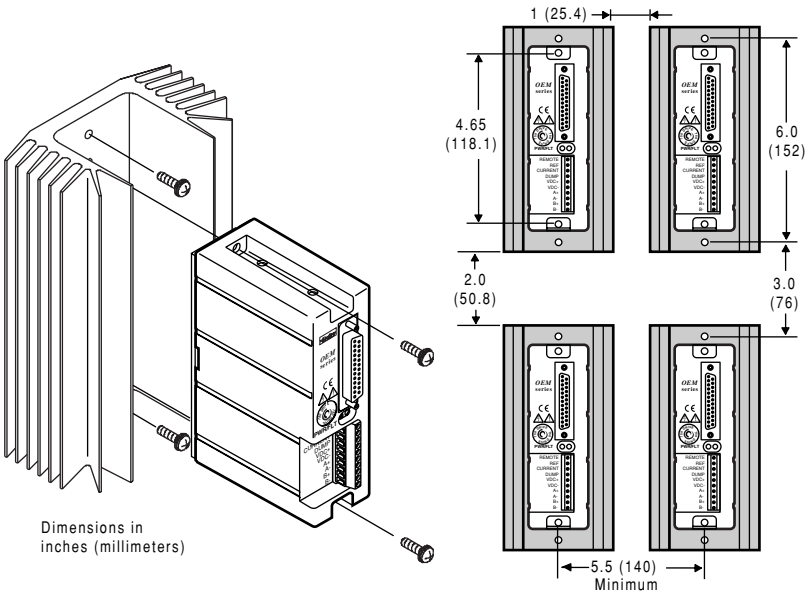

OEM-HS2 Minimum Area Panel Layout

Motor Mounting

Use the flange bolt holes to mount rotary step motors. The *pilot*, or centering flange on the motor's front face, should fit snugly in the pilot hole.

Do not use foot-mount or cradle configurations, because they do not evenly distribute the motor's torque around its case. When a foot mount is used, for example, any radial load on the motor shaft is multiplied by a much longer lever arm.

Motors used with the OEM750/OEM750X can produce very high torques and accelerations. If the mounting is inadequate, the high torque/high acceleration combination can shear shafts and mounting hardware. High acceleration can also produce shock and vibration—therefore, you may need heavier hardware than for static loads of the same magnitude.

Under some move profiles, the motor may produce low-frequency vibrations in the mounting structure that can cause fatigue in structural members. A mechanical engineer should check the machine design to ensure the mounting structure is adequate.

WARNING

Improper mounting can reduce performance and jeopardize personnel safety

Do not modify or machine the motor shaft.

CAUTION

Modifying or machining the motor shaft will cause bearing damage and void the motor warranty. Contact a Compumotor applications engineer (800-358-9070) about shaft modifications as a custom product.

MOTOR TEMPERATURE AND COOLING

The motor's face flange is used not only for mounting—it is also a heat dissipating surface. Mount the face flange to a large thermal mass, such as a thick steel or aluminum plate, which should be unpainted, clean, and flat. Heat will be conducted from inside the motor, through the face flange, and dissipated in the thermal mass. This is the best way to cool the motor. If conduction through the flange does not provide enough cooling, you can also use a fan to blow air across the motor for increased cooling.

Attaching the Load – Couplers

Align the motor shaft and load as accurately as possible. In most applications, some misalignment is unavoidable, due to variations in component tolerance. However, excessive misalignment may degrade system performance. Three misalignment conditions, which can exist in any combination, are:

- Angular Misalignment: The center lines of two shafts intersect at an angle other than zero degrees.
- Parallel Misalignment: The offset of two mating shaft center lines, although the center lines remain parallel to each other.
- End Float: A change in the relative distance between the ends of two shafts.

The type of misalignment in your system will affect your choice of coupler.

Single-Flex Coupling

Use a single-flex coupling when you have angular misalignment only. Because a single-flex coupling is like a hinge, one and only one of the shafts must be free to move in the radial direction without constraint. *Do not use a double-flex coupling in this situation:* it will allow too much freedom and the shaft will rotate eccentrically, which will cause large vibrations and catastrophic failure. *Do not use a single-flex coupling with a parallel misalignment:* this will bend the shafts, causing excessive bearing loads and premature failure.

Double-Flex Coupling

Use a double-flex coupling whenever two shafts are joined with parallel misalignment, or a combination of angular and parallel misalignment (the most common situation).

Single-flex and double-flex couplings may or may not accept end play, depending on their design.

Rigid Coupling

Rigid couplings are generally not recommended, because they cannot compensate for *any* misalignment. They should be used only if the motor is on some form of floating mounts that allow for alignment compensation. Rigid couplings can also be used when the load is supported entirely by the motor's bearings. A small mirror connected to a motor shaft is an example of such an application.

Tuning & Specifications

Chapter Objectives

The information in this chapter will enable you to:

- Tune your drive to your motor, and operate your system at maximum efficiency.
- Use the information to compare system performance with different motor, power, and wiring configurations (speed/torque curves).

Short-Circuit Protection

The OEM750/OEM705X is protected against phase-to-phase and phase-to-ground short circuits. Never short circuit the motor leads for motor braking.

Low Speed Resonance

Resonance exists in all step motors and is a function of the motor's mechanical construction. It can cause the motor to stall at low speeds. Most full step motor controllers jump the motor to a set minimum starting speed that is greater than the resonance region. The OEM750/OEM705X's micro-stepping capability allows you to operate a motor smoothly at all speeds.

Motors that will not accelerate past 1 rps may be stalling due to resonance. You can add inertia to the motor shaft by putting a drill chuck on the shaft. The drill chuck may provide enough inertia to test the motor when it is not connected to the intended load.

Mid-Range Instability

All step motors are subject to mid-range instability. This instability, or oscillation, may stall the motor at speeds from 6 to 16 rps. The OEM750/OEM750X includes active circuitry to help suppress these oscillations. This feature is normally

enabled, but may be disabled by DIP SW2-#1 (see *DIP Switch Functions* in *Chapter 2*) if it has an adverse effect on your system.

Tuning Procedure

Tuning on the OEM750/750X consist of two different aspects. The first is a current loop gain adjustment designed to match the drive's current compensation gain to the motor's inductance and the motor supply voltage. This was described in *Chapter 2, Installation*, in *DIP Switch Functions*. The second is an amplifier adjustment designed to match the amplifier offsets to your specific motor.

You can tune your OEM750/OEM750X to your specific motor. In the procedure below, you will minimize resonance and optimize smoothness by adjusting the small potentiometers on the top of the unit. The next figure shows the location of the potentiometers and their functions.

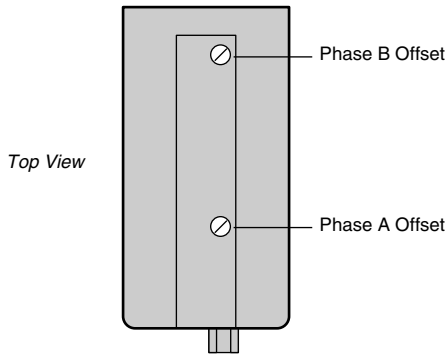

Tuning Potentiometers

- Phase A Offset: Adjusts DC offset of the phase current for Phase A
- Phase B Offset: Adjusts DC offset of the phase current for Phase B

Since tuning is affected by operating current, you may have to adjust these potentiometers during the configuration or installation process. For best results, the drive and motor should be on, connected to the load, and warmed up for 30 minutes prior to tuning.

DETERMINING MOTOR RESONANCE

There are several methods you can use to determine the level of motor resonance in your system.

Tachometer Method

Use an oscilloscope to gauge the output of a tachometer attached to the motor shaft. The tachometer will output a DC voltage, proportional to speed. This voltage will oscillate around an average voltage when the motor is resonating. The amplitude of this oscillation will be at its maximum when you run the motor at its *resonance speed*. The goal of this method is to adjust the system for the lowest oscillation amplitude.

Sounding Board Method

You can practice your tuning skills with an unloaded motor placed on a sounding board or table. When you command a velocity that is near the motor's *resonance speed*, the phenomenon will cause an audible vibration. The goal of this method is to adjust the system for the least amount of vibration.

Stethoscope Method

When you tune your motor under loaded conditions, you can hear the audible vibration caused by the motor's natural frequency by placing the tip of a screw driver against the motor casing and placing the handle of the screw driver close to your ear (as you would a stethoscope). You will also be able to hear the different magnitudes of vibration caused by the motor's natural frequency. The goal of this method is to adjust the system for the least amount of vibration.

Touch Method

After you have had some experience with tuning, you should be able to locate the motor's *resonance speed* by placing your fingertips on the motor shaft and adjusting the motor's velocity. Once the resonance speed is located, you can adjust the system for maximum smoothness.

TUNING THE DRIVE TO THE MOTOR

To tune your drive to your motor, follow these directions:

1. Command the drive (via RS-232C or STEP & DIRECTION inputs) so that the motor is running at maximum roughness, as shown below for the 1st speed motor resonance.

		1st Speed Resonance	2nd Speed Resonance
<u>Size 23</u>			
OS2HA	(OEM57-40)	1.8 rps	3.6 rps
OS21A	(OEM57-51)	1.8 rps	3.6 rps
OS22A	(OEM57-83)	1.8 rps	3.6 rps
<u>Size 34</u>			
RS31B	(OEM83-62)	1.4 rps	2.8 rps
RS32B	(OEM83-93)	1.4 rps	2.8 rps
RS33B	(OEM83-135)	1.4 rps	2.8 rps

2. Adjust Offsets A and B for best smoothness.
3. Double the motor speed (2nd speed resonance) until the motor runs roughly again.
4. Adjust offsets A and B again for best smoothness.
5. Repeat above steps until no further improvement is noted.

ADJUSTING MOTOR CURRENT WAVEFORMS

Step motor manufacturers make every effort to design step motors that work well with sinusoidal current waveforms. However, due to physical limitations, most motors operate best with a current waveform other than a pure sine wave.

The purpose of adjusting motor current waveforms is to cause the step motor to move with equal step sizes as the current waveforms are sequenced through the motor. This waveform adjustment will also help the motor run more smoothly. You can change the waveform with DIP SW2-#6 – SW2-#8

Motor waveforms are usually adjusted after the drive has been tuned to its motor. If you do not have precision measurement equipment, you may select the correct motor waveform with one of the methods described previously in this chapter (Tachometer Method, Sounding Board Method, Stethoscope Method, and Touch Method). These empirical methods generally yield acceptable results.

Performance Specifications

Accuracy	±5.0 arcminutes typical (unloaded, bidirectional) with OS, RS, or OEM Series motors.
Repeatability	±5 arcseconds typical (unloaded, bidirectional).
Hysteresis	Less than 2 arcminutes—0.0334° (unloaded, bidirectional).

Motor Specifications

Speed/torque curves, specifications, and dimensions are shown on the following pages.

MOTOR PART NUMBER – CROSS REFERENCE TABLE

When Compumotor introduced the OEM750/OEM750X, we changed the part numbering system for some existing motors, and introduced several new motors. The next table summarizes the changes and additions. (The letters “n” represent variables that can change, based upon the options ordered.)

<u>Motor Size</u>	<u>New Part Number</u>	<u>Old Part Number</u>
Size 23	OS2HA-SNFLY	OEM57-40-MO
	OS21A-SNFLY	OEM57-51-MO
	OS22A-SNFLY	OEM57-83-MO
Double Shaft:	OS2nA-DNFLY	OEM57-nn-MO-DS23
Encoder:	OS2nA-DNFLY-HJ	OEM57-nn-MO-ENC

OS Series motors are the same motors as OEM57– Series Motors; the new part number is the only difference.

	<u>New Motor</u>	<u>Similar to Existing Motor:</u>
Size 34	RS31B- <i>nnnnn</i>	OEM83-62- <i>nn-<i>nnnn</i></i>
	RS32B- <i>nnnnn</i>	OEM83-93- <i>nn-<i>nnnn</i></i>
	RS33B- <i>nnnnn</i>	OEM83-135- <i>nn-<i>nnnn</i></i>

RS Series motors are similar (but not identical) in size and electrical characteristics to OEM83 Series motors. The motors differ in internal construction. Also, RS motors have cables; OEM83 motors have flying leads, and are internally wired in parallel.

SPEED/TORQUE CURVES

Speed/torque curves are shown below for operation at 24VDC, 48VDC, and 75VDC. Series and parallel curves are shown for 23 frame size motors. Parallel curves only are shown for 34 frame size motors. (OEM83 motors are internally wired in parallel and can only be operated in parallel.)

Power curves are shown as dashed lines.

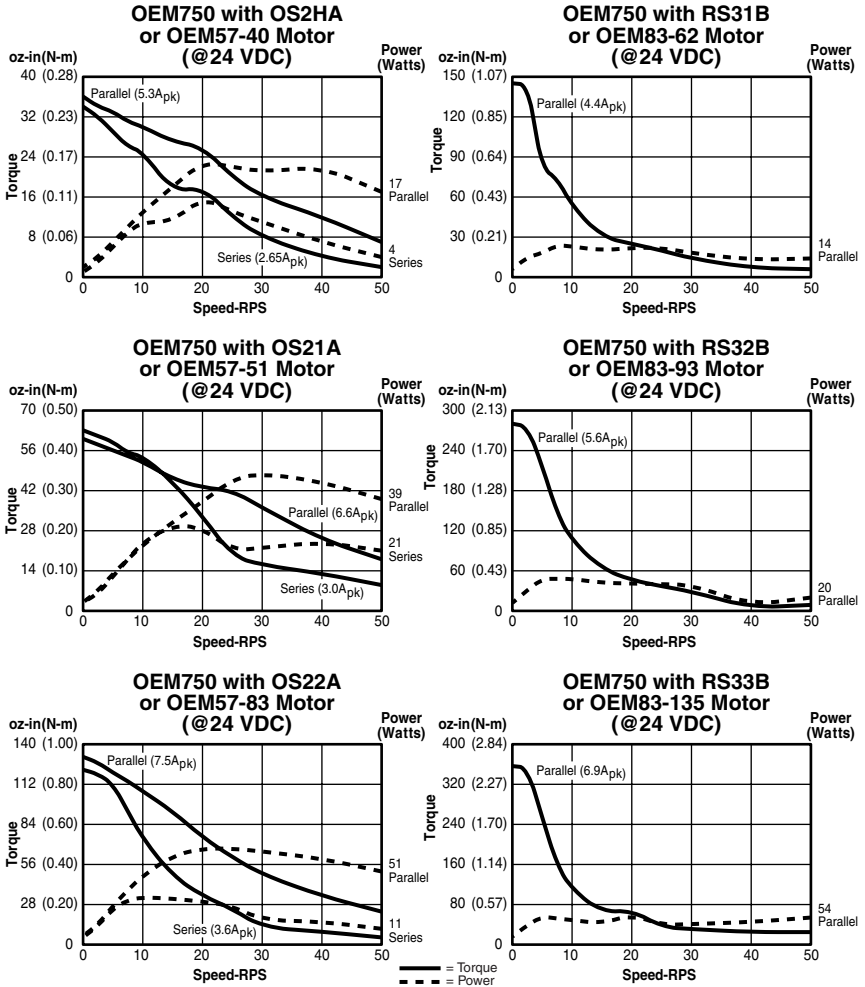

Note 1: Parallel connected motors are limited to 50% duty cycle when operated above 5 rps. For greater than 50% duty cycle above 5 rps, you must connect the motor in series. Fan cooling the motor will increase duty cycles above 5 rps.

Note 2: +/-10% torque tolerance due to motor tolerance

OEM750/OEM750X Speed/Torque Curves at 24VDC

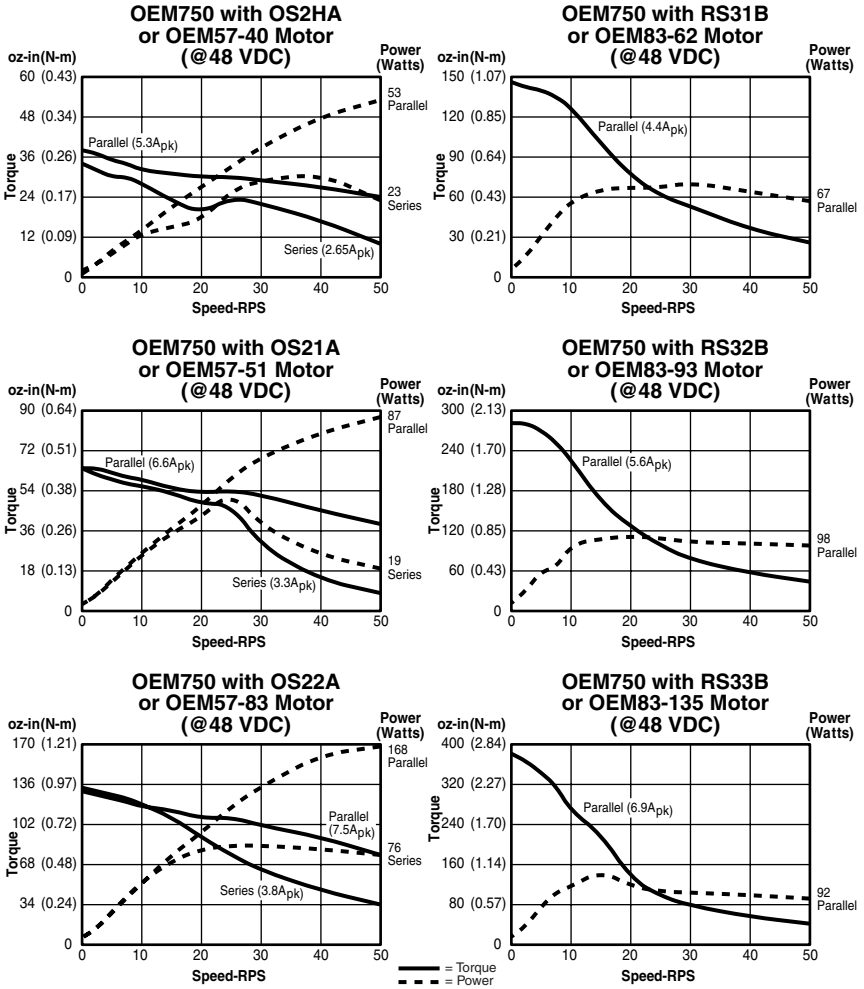

Note 1: Parallel connected motors are limited to 50% duty cycle when operated above 5 rps. For greater than 50% duty cycle above 5 rps, you must connect the motor in series. Fan cooling the motor will increase duty cycles above 5 rps.

Note 2: +/-10% torque tolerance due to motor tolerance.

OEM750/OEM750X Speed/Torque Curves at 48VDC

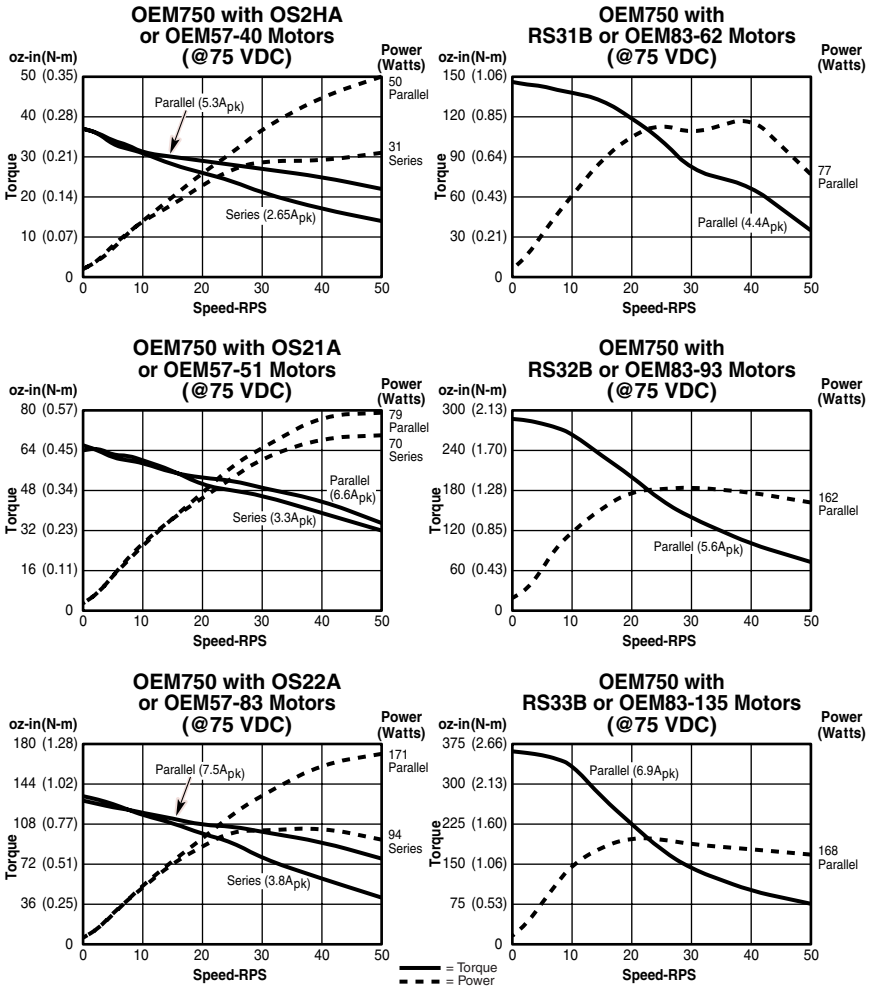

Note 1: Parallel connected motors are limited to 50% duty cycle when operated above 5 rps. For greater than 50% duty cycle above 5 rps, you must connect the motor in series. Fan cooling the motor will increase duty cycles above 5 rps.

Note 2: +/-10% torque tolerance due to motor tolerance.

OEM750/OEM750X Speed/Torque Curves at 75VDC

MOTOR SPECIFICATIONS—23 FRAME SIZE

	OS2HA (OEM57-40)	OS21A (OEM57-51)	OS22A (OEM57-83)
Static Torque**			
oz-in	37	66	133
(Nm)	(0.26)	(0.47)	(0.94)
Rotor inertia			
oz-in ²	0.38	0.65	1.39
(kg-cm ²)	(0.07)	(0.12)	(0.25)
Drive current—Series**			
Apk	2.65	3.3	3.8
(Arms)	(1.9)	(2.3)	(2.7)
Drive current—Parallel**			
Apk	5.3	6.6	7.5
(Arms)	(3.7)	(4.7)	(5.3)
Phase inductance (mH)***			
Series	1.7	1.8	2.8
Parallel	0.4	0.4	0.7
Detent Torque			
oz-in	2.5	4.0	7.0
(Nm)	(0.018)	(0.028)	(0.049)
Bearings Information			
Thrust Load			
lb	13	13	13
(kg)	(5.9)	(5.9)	(5.9)
Radial load			
lb	20	20	20
(kg)	(9.1)	(9.1)	(9.1)
End Play (reversing load equal to 1 lb)			
in	0.001	0.001	0.001
(mm)	(0.025)	(0.025)	(0.025)
Radial Play (per 0.5 lb load)			
in	0.0008	0.0008	0.0008
(mm)	(0.02)	(0.02)	(0.02)
Motor Weight			
lb	1	1.5	2.5
(kg)	(0.45)	(0.68)	(1.14)
Certifications			
UL recognized	Pending	Pending	Pending
CE (LVD)	Yes	Yes	Yes

** Values shown in speed-torque curves at 75VDC

*** Small signal inductance values

MOTOR SPECIFICATIONS—34 FRAME SIZE

	OEM83-62	OEM83-93	OEM83-135	RS31B	RS32B	RS33B
Static Torque**						
oz-in	160	300	400	146	287	361
(Nm)	(1.14)	(2.14)	(2.80)	(1.03)	(2.02)	(2.55)
Rotor inertia						
oz-in ²	3.47	6.76	10.47	3.204	6.563	9.652
(kg-cm ²)	(0.634)	(1.24)	(1.91)	(0.583)	(1.195)	(1.757)
Drive current—Series**						
Apk	n/a	n/a	n/a	n/a	n/a	n/a
(Arms)	n/a	n/a	n/a	n/a	n/a	n/a
Drive current—Parallel**						
Apk	4.4	5.6	6.9	4.4	5.6	6.9
(Arms)	(3.1)	(4.0)	(4.9)	(3.1)	(4.0)	(4.9)
Phase inductance (mH)***						
Series	n/a	n/a	n/a	11.6	11.6	9.6
Parallel	2.2	2.2	2.2	2.9	2.9	2.4
Detent Torque						
oz-in	4	8	10	8.8	18.0	27.0
(Nm)	(0.029)	(0.058)	(0.072)	(0.062)	(0.130)	(0.190)
Bearings Information						
Thrust Load						
lb	50	50	50	180	180	180
(kg)	(22.6)	(22.6)	(22.6)	(81.6)	(81.6)	(81.6)
Radial load						
lb	25	25	25	35	35	35
(kg)	(11.3)	(11.3)	(11.3)	(15.9)	(15.9)	(15.9)
End Play (reversing load equal to 1 lb)						
in	0.005	0.005	0.005	0.001	0.001	0.001
(mm)	(0.013)	(0.013)	(0.013)	(0.025)	(0.025)	(0.025)
Radial Play (per 0.5 lb load)						
in	0.0008	0.0008	0.0008	0.0008	0.0008	0.0008
(mm)	(0.02)	(0.02)	(0.02)	(0.02)	(0.02)	(0.02)
Motor Weight						
lb	3.8	5.1	8.3	3.2	5.3	7.6
(kg)	(1.7)	(2.3)	(3.7)	(1.45)	(2.41)	(3.45)
Certifications						
UL recognized	No	No	No	Yes	Yes	Yes
CE (LVD)	No	No	No	Yes	Yes	Yes

** Values shown in speed-torque curves at 75VDC

*** Small signal inductance values

MOTOR DIMENSIONS

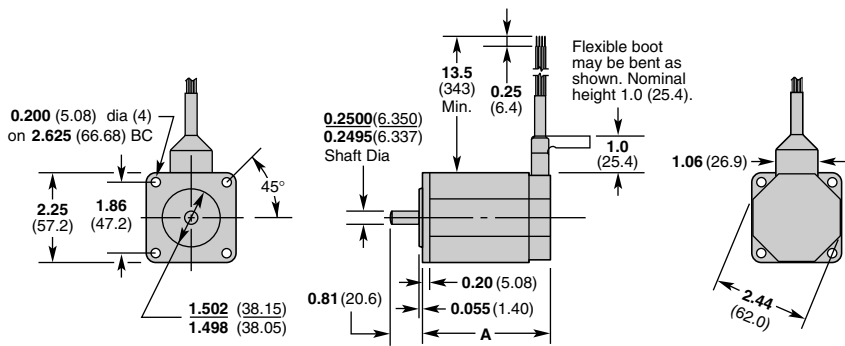

Frame Size 23

Model	A
OS2HA (OEM57-40)	1.60 (40.7)
OS21A (OEM57-51)	2.06 (52.4)
OS22A (OEM57-83)	3.10 (78.8)

Dimensions in inches (millimeters)

Size 23 Frame, OS Series and OEM57 Series Motors

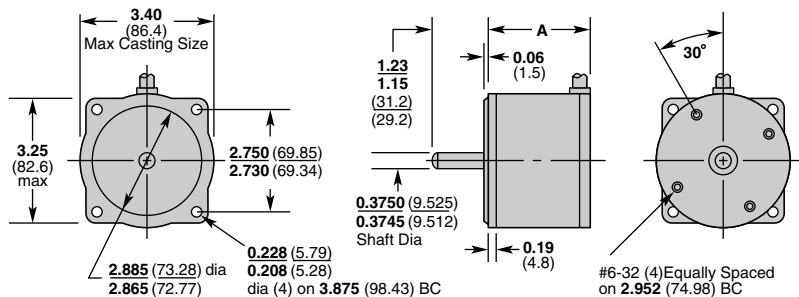

Frame Size 34

Model	A
OEM83-62	2.50 (63.5)
OEM83-93	3.70 (94.0)
OEM83-135	5.20 (132.1)

Dimensions in inches (millimeters)

Size 34 Frame, OEM83 Series Motors

③ Tuning & Specifications • OEM750

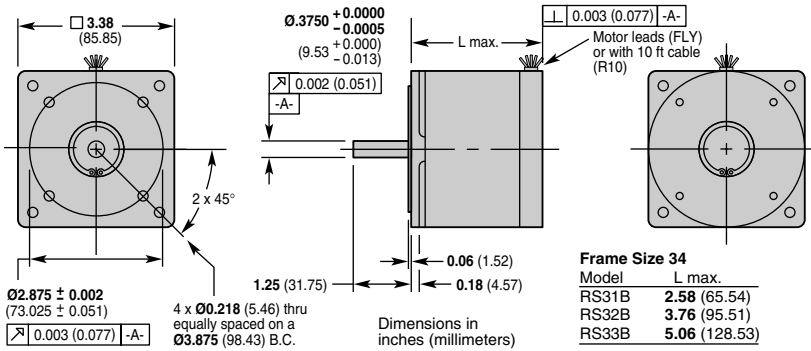

Size 34 Frame, RS Series Motors, Regular Construction

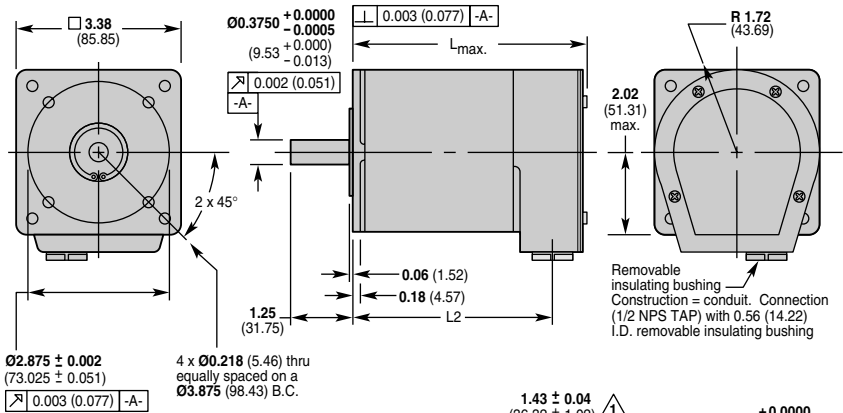

Dimensions in inches (millimeters)

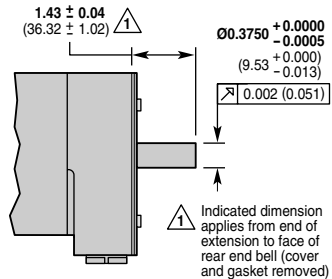

Double Shaft Configuration

Size 34 Frame, RS Series Motors, End Bell Construction (NPS)

Encoder Specifications

ENCODER DIMENSIONS

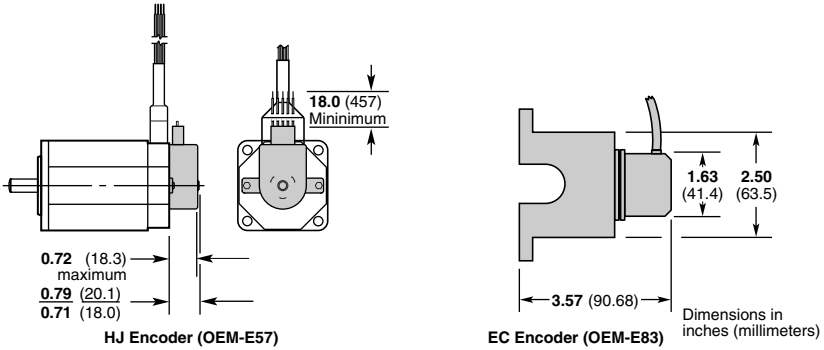

Dimensions – HJ (OEM-E57) and EC (OEM-E83) Encoders

ENCODER RESOLUTION

Model	Lines
HJ (OEM-E57)	512 Lines
EC (OEM-E83)	1000 Lines

ENCODER WIRES—COLOR CODE—HJ (OEM-E57)

Function	Wire Color	OEM750X D-Connector PIN Number
Channel A	White	17
Channel B	Brown	18
Channel Z	Blue	19
+5 volts	Red	
Ground	Black	7

ENCODER WIRES—COLOR CODE—EC (OEM-E83)

Function	Wire Color	OEM750X D-Connector PIN Number
Channel A+	Brown	17
Channel A-	Brown/White	Do not connect
Channel B+	Green	18
Channel B-	Green/White	Do not connect
Channel Z+	Orange	19
Channel Z-	Orange/White	Do not connect
+5 volts	Red	
Ground	Black	7
	Shield	Do not connect

This page left blank intentionally.

Troubleshooting

Chapter Objectives

The information in this chapter will enable you to:

- Maintain the system to ensure smooth, efficient operation
- Isolate and resolve system problems

Drive Maintenance

Ensure that the drive's heatplate has proper thermal contact with the mounting surface. Enclosures must be connected to earth ground through a grounding electrode conductor to provide a low-impedance path for ground-fault or noise-induced currents (use a star washer with the lower mounting screw on the drive). All earth ground connections must be continuous and permanent. Periodically check the mounting screws to ensure they are tight.

Motor Maintenance

Inspect the motor regularly to ensure that no bolts or couplings have become loose during normal operation. This will prevent minor problems from developing into more serious problems.

Inspect the motor cable periodically for signs of wear. This inspection interval is duty-cycle, environment, and travel-length dependent. The cable should not have excessive tensile force applied to it and should not be bent beyond a one-inch radius of curvature during normal operation. Tighten all cable connectors.

Reducing Electrical Noise

For detailed information on reducing electrical noise in your system, refer to *Appendix B, EMC Installation Guide*.

Problem Isolation

When your system does not function properly (or as you expect it to operate), the first thing that you must do is identify and isolate the problem. When you accomplish this, you can effectively begin to resolve and eradicate the problem.

The first step is to isolate each system component and ensure that each component functions properly when it is run independently. You may have to dismantle your system and put it back together piece by piece to detect the problem. If you have additional units available, you may want to exchange them with existing components in your system to help identify the source of the problem.

Determine if the problem is mechanical, electrical, or software-related. Can you repeat or re-create the problem? Random events may appear to be related, but they may not be contributing factors to your problem.

You may be experiencing more than one problem. You must isolate and solve one problem at a time. Log (document) all testing and problem isolation procedures. You may need to review and consult these notes later. This will also prevent you from duplicating your testing efforts.

Once you isolate the problem, take the necessary steps to resolve it. Use the solutions in this chapter. If your system's problem persists, contact your local technical support resource.

FRONT PANEL LEDs

The OEM750/OEM750X has two LEDs on its front panel.

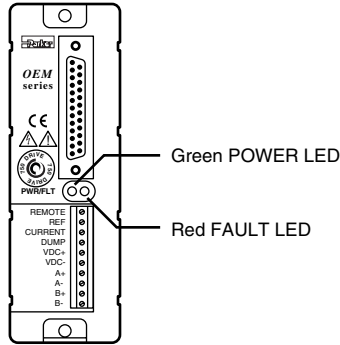

LEDs

The FAULT LED is red and illuminates when the amplifier is disabled. This LED is activated when any of the following conditions occur:

- Motor short circuit detected
- Drive overtemperature
- Internal fault detected

The POWER LED is green and illuminates when the internal power supply is operating and providing +5V.

COMMON PROBLEMS AND SOLUTIONS

The following table will help you eradicate most of the problems you might have with the OEM750/OEM750X.

Symptoms	Probable Causes	Solutions
The drive loses pulses at high speed	Indexer is overdriving step input	Verify that the step input current is not greater than 15 mA
	Indexer is underdriving step input	Verify that the step input current is greater than 6.25 mA
	Indexer is sending pulses too fast	Verify that the indexer is not exceeding the 2 Mhz maximum pulse rate
	Motor is out of torque	Verify that the motor is sized correctly for your application
The motor stalls at high speeds	The velocity is too high	The drive can handle a maximum pulse rate of 2 Mhz or 50 rps, whichever comes first decrease the velocity
	Motor current is not set correctly	Check the current select resistor and verify that the current is set correctly
	Loop gain is not set correctly	Verify correct current loop gain setting for the motor inductance and supply voltage you are using
	Motor is undersized for application	Verify that the motor is sized correctly for your application
The motor stalls during acceleration	Motor current is not set correctly	Check the current select resistor and verify that the current is set correctly
	The acceleration is set too high	Decrease the acceleration
	There is insufficient rotor inertia	Add inertia to the motor shaft
	Loop gain is not set correctly	Verify correct current loop gain setting for the motor inductance and supply voltage you are using
	Motor is undersized for application	Verify that the motor is sized correctly for your application
The motor (unloaded) stalls at nominal speed	Loop gain is not set correctly	Verify correct current loop gain setting for the motor inductance and supply voltage you are using
	There is insufficient rotor inertia	Add inertia to the motor shaft
	Mid-frequency resonance	Verify anti-resonance is enabled
Motor does not move commanded distance	Motor resolution is set incorrectly	Determine the resolution on your indexer and verify that the drive resolution setting is the same
Motor will not change direction as commanded	The direction input is not being enabled	Verify that the direction input is being enabled (6.4 mA to 15 mA)

Symptoms	Probable Causes	Solutions
Indexer moves motor in wrong direction	There is a direction conflict within the indexer	Change direction within your indexer or by swapping motor leads A+ and A- at the drive connector
When a move is commanded, no motion occurs	A limit may be enabled and active	Check hard limit or disable limits with the LD3 command
	You may be in Absolute mode and are already at the position you are commanding the motor to move to	Try another distance and issue Go (G) command
The unit may appear to not be responding to commands	If you defined a sequence and never issued XT, the OEM750/OEM750X still thinks you are defining a sequence	Issue an XT command at the end of the sequence to end sequence definition
	OEM750X may be off-line (F command)	Issue an E command to bring the unit on-line
Power LED is not on (illuminated)	The drive is not receiving adequate DC voltage	Verify the VDC+ and VDC- connection Verify your power supply is producing adequate power Verify that there is DC voltage at the drive and at the VDC+ and VDC- connection
	Drive screw terminals are loose	Tighten screws – do not tin wires
Power LED is flashing	DC Line voltage is too low I/O incorrectly connected	Check DC line voltage (24 VDC minimum)
	Internal damage to the drive	Remove 25-Pin D connector to isolate the problem Return drive to Compumotor for servicing
There is little or no holding torque; the power LED is on; the motor fault LED is off	The incorrect current select resistor is being used	Verify the current selector resistor with the correct table – measure the resistor with an ohmmeter
	The current select resistor is not installed or loose	Check for current select resistor, tighten screws, check wiring
	Current range switches not set correctly	Verify setting. See manual.
	Remote input activated	Remove 25-pin D connector to isolate the problem
	Auto standby function enabled	Check switches SW3-1, SW3-2

Symptoms	Probable Causes	Solutions
The motor fault LED is on	The drive has detected a short circuit in the motor wiring	Check for miswiring— carefully check the motor wires for loose strands shorting the windings
	The drive is overheating	Verify that the drives heatsink does not exceed 55°C
	The drive may have internal damage	Return the drive to Compumotor for servicing
The motor moves erratically at low speeds	Motor current is set incorrectly	Check the current select resistor and verify that the current is set correctly
	Indexer pulses are being sent to the drive erratically	Verify, with an oscilloscope, that the indexer pulses are being sent at a constant rate and are not being frequency modulated
	Motor resolution is set for 200 or 400 steps per revolution	Full and half step modes will cause the motor to run roughly at low speeds
	Loop gain is not set correctly	Verify correct current loop gain setting for the motor inductance and supply voltage you are using
	1 motor phase is open	Check wiring. Measure motor winding resistance at the drive (remove power)

Testing the Motor

If the motor fails to move, you should test the motor with an ohmmeter to examine the resistance between the motor connections. If the motor is not malfunctioning, the source of the problem is probably within the drive. If you operate a faulty drive with a reliable motor, you may damage the motor. If you find that the drive is not faulty, remove power, and remove the motor from the drive. Use the following steps to test the motor.

1. Remove power from the system. Detach the motor from the drive.
2. With the motor detached from the system, use an ohmmeter to check the resistance across Phase A. It should be approximately 2 ohms.
3. Use the ohmmeter to check the resistance across Phase B. It should be approximately 2 ohms, also (*the resistance across Phase A and Phase B should be nearly identical*).
4. Use the ohmmeter to check the resistance between Phase A and Phase B. **It should be infinite.**
5. Use the ohmmeter to check the resistance between Phase A and Earth (the motor case shaft). **It should be infinite.**

6. Use the ohmmeter to check the resistance between Phase B and Earth (the motor case shaft). **It should be infinite.**
7. Turn the shaft manually. There should not be any torque.

If the motor responds as described to each of these steps, it is functioning properly. The source of the problem is probably within the drive.

RS-232C Problems

Use the following procedure to troubleshoot communication problems that you may have with the OEM750X.

1. Be sure the host computer's transmit (Tx) wire is wired to the peripheral's receive (Rx) connection, and the host computer's receive (Rx) wire is wired to the peripheral's transmit (Tx) connection. Switch the receive and transmit wires on either the host or peripheral if the problem persists.

CAUTION

OEM750X Rx, Tx, and GND pins are not 2, 3, and 7 like most devices.

2. Confirm that the host and peripheral are configured for the same baud rate, 8 data bits, 1 stop bit, and no parity.
3. Use DC common or signal ground (pin 7) as a reference, not earth ground.
4. Cable lengths should not exceed 50 feet (15 m) unless you are using some form of line driver, optical coupler, or shield. As with any control signal, be sure to shield the cable-to-earth ground at one end only.
5. To test the terminal or terminal emulation software and the RS-232C cable for proper three-wire communication, unhook the OEM750X and enter a character. You should not receive an echoed character. If you do, you are in half duplex mode. Connect the host's transmit and receive lines together and send another character. You should receive the echoed character. If not, consult the manufacturer of the host's serial interface for proper pin outs.
6. (Note: This only applies to firmware 92-016638-01). If the controller echoes back **&** for each byte sent to the controller, a data communication error has occurred. To re-establish communication, see the **%** command.
7. (Note: This only applies to firmware 92-016638-01). To extend cable length and/or improve noise immunity, RS-485 option is available as a custom product request. Contact the Custom Products department for details.
8. (Note: This only applies to firmware 92-016638-01). If commands are being lost intermittently while data streaming, reference the **XONOFF** command for using software flow control.

Software Debugging Tools

The OEM750/OEM750X has several tools that you can use to debug a problem in the system. The software tools are listed below:

RA	Limit Switch Status Report
R	Report Status
IS	Input Status Report
BS	Buffer Status Report
B	Buffer Status Report

Returning the System

If your OEM750/OEM750X system is faulty, you must return the drive and motor for replacement or repair. A failed drive can damage motors. If you must return your OEM750/OEM750X to effect repairs or upgrades, use the following steps:

1. Get the serial number and the model number of the defective unit(s), and a purchase order number to cover repair costs in the event the unit is determined to be out of warranty.
2. Before you return the unit, have someone from your organization with a technical understanding of the OEM750/OEM750X and its application include answers to the following questions:
 - What is the extent of the failure/reason for return?
 - How long did it operate?
 - Did any other items fail at the same time?
 - What was happening when the unit failed (i.e., installing the unit, cycling power, starting other equipment, etc.)?
 - How was the unit configured (in detail)?
 - What, if any, cables were modified and how?
 - With what equipment is the unit interfaced?
 - What was the application?
 - What was the system sizing (speed, acceleration, duty cycle, inertia, torque, friction, etc.)?
 - What was the system environment (temperature, enclosure, spacing, unit orientation, contaminants, etc.)?
 - What upgrades, if any, are required (hardware, software, user guide)?
3. In the USA, call your Automation Technology Center (ATC) for a Return Material Authorization (RMA) number. Returned products cannot be accepted without an RMA number. If you cannot obtain an RMA number from your ATC, call Parker Compumotor's Customer Service Department at (800) 722-2282.

Ship the unit to: Parker Compumotor Corporation
5500 Business Park Drive
Rohnert Park, CA 94928
Attn: RMA # xxxxxxx

4. In the UK, call Parker Digiplan for a GRA (Goods Returned Authorization) number. Returned products cannot be accepted without a GRA number. The phone number for Parker Digiplan Repair Department is 0202-690911. The phone number for Parker Digiplan Service/Applications Department is 0202-699000.

Ship the Unit to: Parker Digiplan Ltd.,
 21, Balena Close,
 Poole, Dorset,
 England. BH17 7DX

5. Elsewhere: Contact the distributor who supplied the equipment.

This page left blank intentionally.

A P P E N D I X A

LVD Installation Instructions

For more information about LVD, see 73/23/EEC and 93/68/EEC, published by the European Economic Community (EEC).

ENVIRONMENTAL CONDITIONS

Pollution Degree

The OEM750/OEM750X is designed for pollution degree 2.

Installation Category

The OEM750/OEM750X is designed for installation category II.

ELECTRICAL

Connecting and Disconnecting Power

The OEM750/OEM750X's protective earth connection is provided through its heatsink. You must reliably earth the OEM750/OEM750X's protective earth connection.

Attach or remove the OEM750/OEM750X's power connections only while input power is OFF.

The OEM750/OEM750X's supply voltage is limited to 75 VDC.

Connecting the Protective Conductor Terminal to Earth

You must provide a connection from the OEM750/OEM750X's protective conductor terminal to a reliable earth point.

The protective conductor terminal is marked with a label on the product bearing the following symbol:



Protective Conductor Terminal Marking

To connect the protective conductor terminal to earth, complete these steps:

- ① Use a ring terminal in combination with a star washer to make good contact with the exposed metal surface surrounding one of the OEM750/OEM750X's mounting holes. (The dimension drawing in *Chapter 2* indicates the mounting hole that has exposed metal.)
- ② Use a VDE approved green/yellow protective conductor terminal wire to reliably earth the protective conductor terminal. Wire gauge must be no thinner than the current-carrying wire in the product's mains supply.
- ③ Resistance between the protective conductor terminal and earth must be no greater than 0.1 Ω . Use thicker gauge wire if the resistance is too high.

Providing a Protective Earth Connection for Motors

You must provide a connection from the motor to a reliable protective earth. This connection provides a protective earth for the motor contact point. The motor's protective earth connection is important for safety reasons, and *must not be omitted*.

Compumotor's OS Series, RS Series motors with the L10 option, and OEM83 Series motors have permanently attached cables that do not contain protective conductors (earth wires). If you use one of these motors, or any other motor without a protective conductor, make connections according to the following instructions and diagram:

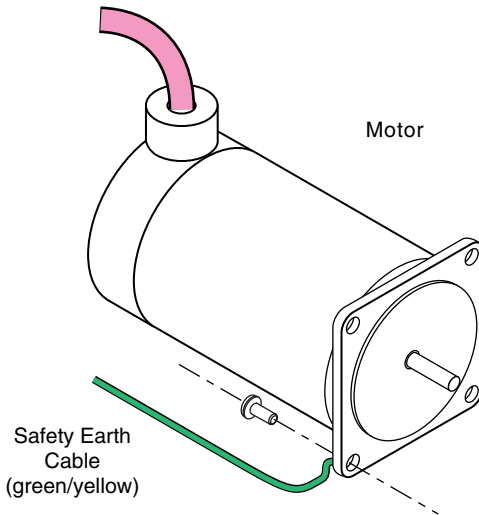

Motor – Earth Connection

- ① Use a ring terminal in combination with a star washer and mounting bolt to make good contact with the bare metal surface of the motor's mounting flange.
- ② Use a VDE approved green/yellow protective conductor terminal wire to make the connection between the motor and earth. Wire gauge must be no thinner than the current carrying wire in the motor's power cable.
- ③ Resistance between the motor and earth must be no greater than 0.1 Ω . Use thicker gauge wire if the resistance is too high.

Compumotor's RS Series motors with the C10 option have a protective conductor in the removable cable. If you use one of these motors, or any other motor with a protective conductor in its cable, connect the protective conductor to a reliable protective earth point. Follow the motor manufacturer's installation instructions.

MECHANICAL

Installing in an Enclosure

The OEM750/OEM750X must be installed within an enclosure. The enclosure's interior must not be accessible to the operator. The enclosure should be opened only by skilled or trained service personnel.

Do Not Operate the OEM750/OEM750X Without Cover

The cover provides mechanical support to the circuit assemblies inside.

SERVICING THE OEM750/OEM750X

Changing Firmware

Only skilled or trained personnel should change firmware.

THERMAL SAFETY

The Motor May Be Hot

The motor may reach high temperatures during normal operations, and may remain hot after power is removed.







SONIC PRESSURE

High Sound Level

The sound level from some large frame step motors (NEMA 34, NEMA 42, and larger) may exceed 85 dBA. Actual sound level is application dependent, and varies with motor loads and mounting conditions. Measure the sound level in your application; if it exceeds 85 dBA, install the motor in an enclosure to provide sound baffling, or provide ear protection for personnel.

Table of Graphic Symbols and Warnings

The following symbols may appear in this user guide, and may be affixed to the products discussed in this user guide.

Symbol	Description
	Earth Terminal
	Protective Conductor Terminal
	Frame or Chassis Terminal
	Equipotentiality
	Caution, Risk of Electric Shock
	Caution, Refer to Accompanying Text
	Hot Surface

EMC Installation Guide

General Product Philosophy

Meeting requirements for electromagnetic compatibility (EMC) compliance will require specific measures to be taken during installation of the OEM750/OEM750X. The ultimate responsibility for ensuring that the EMC requirements are met rests with the systems builder.

It is important to remember that for specific installations, the full protection requirements of the EMC Directive 89/336/EEC need to be met before the system is put into service. This must be verified either by inspection or by testing. The following EMC installation recommendations are intended to assist in ensuring that the requirements of the EMC directive are met. It may be necessary to take additional measures in certain circumstances and at specific locations.

Although these recommendations are based on expertise acquired during tests carried out on the OEM750/OEM750X, it is impossible for Compumotor to guarantee the compliance of any *particular* installation. Compliance will be strongly influenced by the physical and electrical details of the installation and the performance of other system components. Nevertheless it is important to follow **all** the installation instructions if an adequate level of compliance is to be achieved.

Safety Considerations

These products are intended for installation according to the appropriate safety procedures including those laid down by the local supply authority regulations. The recommendations provided are based on the requirements of the Low Voltage Directive and specifically on EN60204. It should be remembered that safety must never be compromised for the purpose of achieving EMC compliance. Therefore in the event of a conflict occurring between the safety regulations and the following recommendations, ***the safety regulations always take precedence.***

General Considerations

EXTERNAL ENCLOSURES

The measures described in these recommendations are primarily for the purpose of controlling conducted emissions. To control radiated emissions, all drive and control systems must be installed in a steel equipment cabinet which will give adequate screening against radiated emissions. This external enclosure is also required for safety reasons. There must be *no user access* while the equipment is operating. This is usually achieved by fitting an isolator switch to the door assembly. The OEM750/OEM750X must be mounted to a conductive, earthed panel. If this has a paint finish, it will be necessary to remove the paint in certain areas where specified.

To achieve adequate screening of radiated emissions, all panels of the enclosure must be bonded to a central earth point. The enclosure may also contain other equipment and the EMC requirements of these must be considered during installation. Always ensure that drives are mounted in such a way that there is adequate ventilation.

AC SUPPLY FILTERING

These recommendations are based on the use of proprietary screen filter units which are readily available. However the full EMC test includes a simulated lightning strike which will damage the filter unless adequate surge suppression devices are fitted. These are not normally incorporated into commercial filters since the lightning strike test can be destructive. This test is normally carried out on the overall system and not on individual components, therefore the surge protection should be provided at the system boundary.

Try to arrange the layout of drive, power supply and filter so that the AC input cable is kept away from the filter output leads. It is preferable for the current path to be as linear as possible without doubling back on itself - this can negate the effect of the filter. Mount the filter within 2 inches (50mm) of the power supply or transformer, if required, and run the input cable and any earth cables close to the panel.

CONTROL SIGNAL CONNECTIONS

High-quality braided-screen cable should be used for control connections. In the case of differential inputs, it is preferable to use cable with twisted pairs to minimize magnetic coupling. This applies to both analog and digital signals. Control cables leaving the enclosure should have the cable screen returned to a local ground point near the product. Where screened leads are used in control circuits that are only opto-isolated at one end, the screen must be referenced to earth at the non-isolated end. Where there is isolation at both ends of the connection, earth the screen at the receiving end. This is to give protection against coupled noise impulses and fast transient bursts.

Remember to route control signal connections well away from relays and contactors—at least 8 inches (200 mm). Control wiring should not be laid parallel to power or motor cables and should only cross the path of these cables at right angles. Bear in mind that control cables connected to other equipment within the enclosure may interfere with the controller or drive, particularly if they have come from outside the cabinet. Take particular care when connecting external equipment with the cabinet door open, for instance a computer or terminal; static discharge may cause damage to unprotected inputs.

MOTOR CABLING

In order to prevent electrical cross-talk, motor cables not incorporating a braided screen shield must remain within earthed metal conduit the entire exposed length of travel. It is advised that each high power motor cable utilize its own conduit.

FERRITE ABSORBER SPECIFICATIONS

The absorbers described in these installation recommendations are made from a low-grade ferrite material which has high losses at radio frequencies. They therefore act as a lossy element in this waveband.

The recommended components are produced by Parker Chomerics (617-935-4850) and are suitable for use with cable

having an outside diameter up to 10 – 13mm. The specification is as follows:

Chomerics part number	83-10-M248-1000	83-10-A637-1000
Outside diameter	17.5mm (0.69 in.)	28.5mm (1.12 in.)
Inside diameter	10.7mm (0.42 in.)	13.77mm (0.54 in.)
Length	28.5mm (1.12 in.)	28.57mm (1.13 in.)
Impedance at 25MHz	80Ω	135Ω
Impedance at 100MHz	120Ω	210Ω
Curie temperature	130°C	130°C

(the device should not be operated near this temperature)

HANDLING AND INSTALLING THE FERRITE ABSORBERS

Take care when handling the absorbers—they can shatter if dropped on a hard surface. For this reason the suggested method of installation is to use a short length of heat-shrink sleeving, as shown below. This gives a degree of physical protection while the cable is being installed. The sleeving should have a shrink ratio of at least 2.5:1. Cable ties may be used as an alternative; however, they give no physical protection to the absorber.

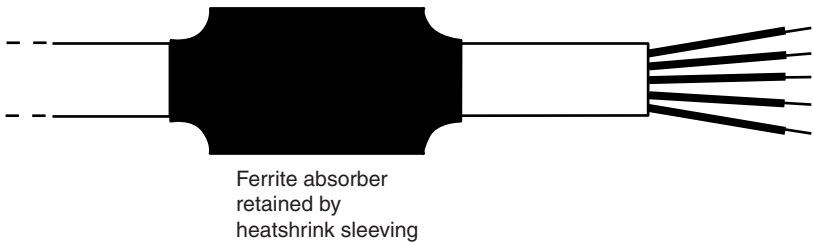

Ferrite Sleeve Installation

R-CLAMP INSTALLATION DETAILS

The function of the R-clamp is to provide a 360 degree metallic contact and thus a convenient means of ensuring a proper radio frequency ground. When dealing with electromagnetic interference issues, it is important to remember that continuity—a DC connection—does not at all speak to the integrity of an AC (high-frequency) bond. High-frequency bonding typically involves wide, flat cabling to establish a suitable system ground. When applied properly, the R-clamp has been shown to give an adequate high-frequency contact.

When installing an R-clamp, as shown in the next figure, install it as close to the cable end as possible. Mount the R-clamp to a suitable ground, backplane, earth stud or bus bar—this may require removing paint from a cabinet or panel.

Remove only the outer (vinyl) jacket of the braided screen cable; this allows the braid to continue to the cable connector. Be careful not to damage the braid. Snap the R-clamp over the exposed braid, and adjust for a tight fit. Secure the clip to the designated ground with a machine screw and lock washer. The use of brass or other inert conductive metal R-clamp is recommended. Cover any exposed bare metal with petroleum jelly to resist corrosion.

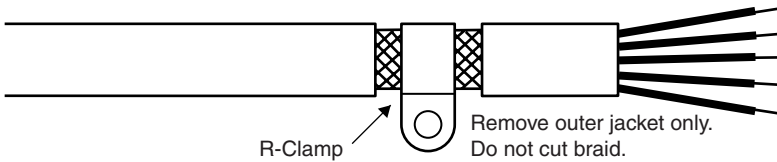

R-Clamp Installation

OEM Series Products

Applicable Products: OEM750, OEM750X, OEM300, OEM1000

Please read this section in conjunction with the general considerations applicable to all products.

EXTERNAL ENCLOSURE

Before mounting the drive, ensure that the mounting location is flat and free from paint or other non conductive surface coatings, if necessary remove paint from the corresponding mounting area. This is to guarantee a good high-frequency connection between the drive case and the cabinet. After mounting the unit use petroleum jelly on the exposed metal to minimize the risk of future corrosion. Do not forget to insert a thermally conductive strip or apply thermal paste between the drive and mounting area, if the mounting location is to serve as a heatsink.

FILTERING THE DC POWER SUPPLY

In most installations, the DC power supply (providing DC voltage to the OEM Drive) will require fitting of a mains filter. A suitable filter and particular mounting recommendations should be made available by the power supply manufacturer.

When using Compumotor's OEM300 or OEM1000 DC power supply delivering less than 300 watts, or the OEM1000 delivering more than 300 watts, the recommended mains filters are:

Compumotor Product	Recommended AC Input Filter	
OEM300	CORCOM	6VN1
	SCHAFFNER	FN670-3/06
OEM1000 (< 300 Watts)	CORCOM	6VN1
	SCHAFFNER	FN670-3/06
OEM1000 (> 300 Watts)	CORCOM	10VN1
	SCHAFFNER	FN670-10/06

Corcom World Headquarters
Phone: 847-680-7400
Fax: 847-680-8169

Schaffner EMC Inc.
Phone: 201-379-7778
Fax: 201-379-1151

Mount the filter within 2 inches (50mm) of the power supply (see the next figure). Ensure that there is no paint on the mounting panel under the filter mounting lugs - it is vital that there is a large-area conductive contact between the filter and the panel.

Connect the incoming AC supply cable to the push-on terminals on the filter, with the earth lead connected to a local earth stud, bus bar or metal backplane. Route the supply cable so that it runs close to the walls of the enclosure. Connect the earth terminal on the filter case to the earth stud.

Fit a ferrite absorber over the cable before wiring the filter output terminals to the AC input on the power supply. Locate the absorber as close as possible to the power supply using heat-shrink sleeving (see the next figure). Take the power supply earth connection from the same stud that retains the filter case earth.

Attach the DC power supply output to the OEM750/OEM750X, using 2-core 1.5mm^2 (AWG 14) (SWG 16) twisted wiring, as shown in the next figure. Route these wires away from motor cables and other high current cabling, while keeping their length as short as possible.

The filters specified above allow multiple OEM series drives to be used with Compumotor's OEM300 or OEM1000 power supplies, that is, one filter per DC power supply.

Motor Connections

COMPUMOTOR MOTORS, AND OTHER MOTORS WITH NON-REMOVABLE CABLING

Except for the C10 cabling option of the RS motors, Parker Compumotor OEM Series drive/motor systems ship with motors that do not incorporate braided screen. (Applicable motors are OS Series, RS Series with the L10 option, and OEM Series motors.)

Therefore when motor cabling is not confined within earthed conduit, it is necessary to shield the exposed length of cable and properly bond it to earth. In installations where the motor cable is within earthed conduit for the entire length of travel, the standard motor cable can be used.

To extend motor cables cut off cable in excess of approximately 4 inches (10 cm). Configure the motor for series or parallel operation and attach the braided screen cable to the motor. The use of a terminal block or other hardware is recommended, as inline splicing on high power cables is not allowed.

Termination of the braid shield at the motor must be made using a 360° bond to the motor body. This may be achieved by using a suitable clamp. R-clamp the braid (see previous figure) to the rear end bell of the motor housing, shown in the next figure. This will not only provide a good high frequency bond, but strain relief as well.

At the drive end of the motor cable, fit a ferrite absorber over the cable before wiring to the motor connector. Locate the absorber as close as possible to the connector using heat-shrink sleeving. Expose a short length of braiding and anchor to the panel with an R-clamp. Note that the motor cable should be kept away from I/O cables carrying control signals.

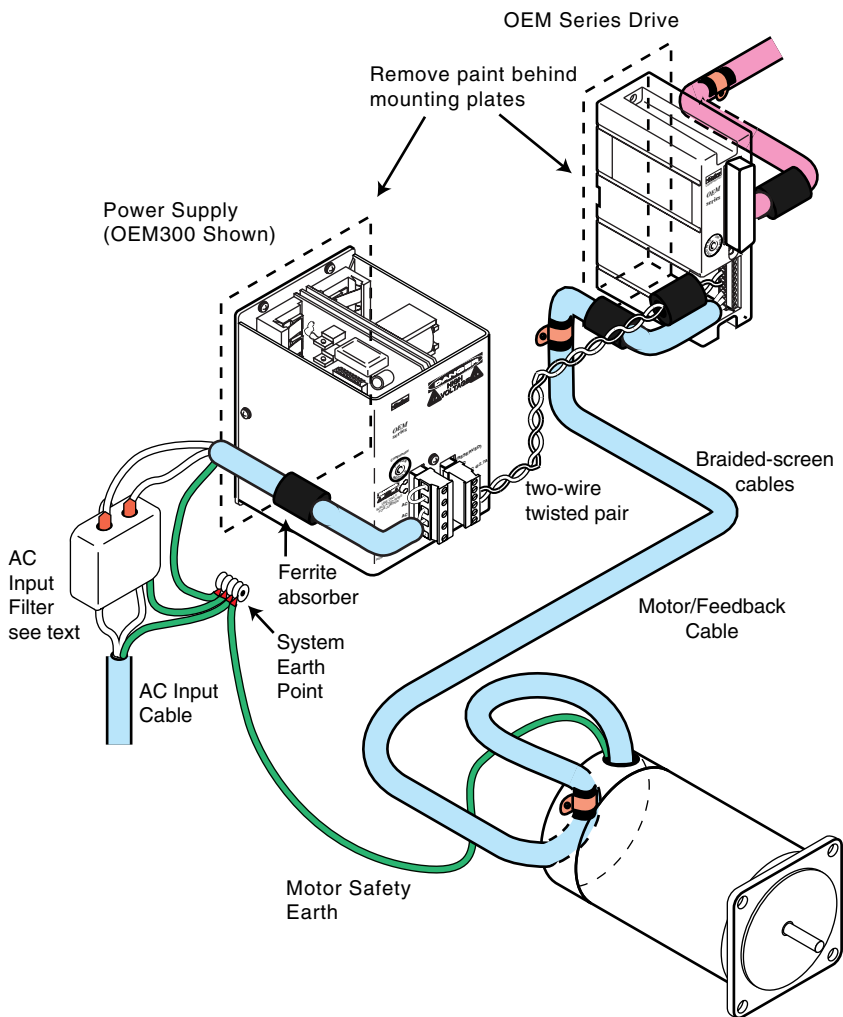

Motor with Non-Removable Cabling

COMPUMOTOR RS SERIES MOTOR WITH C10 OPTION

The C10 option for Compumotor's RS Series motors includes a removable braided cable and all necessary hardware for making an EMC compliant installation. At the motor end of the motor cable, follow the installation instructions that are included with the C10 cable kit.

At the drive end of the motor cable, fit a ferrite absorber over the cable before wiring to the motor connector. Locate the absorber as close as possible to the connector using heat-shrink sleeving. Expose a short length of braiding and anchor to the panel with an R-clamp. Note that the motor cable should be kept away from I/O cables carrying control signals.

OTHER MOTORS WITH REMOVABLE CABLING

Remove the motor cable from the standard motor, and replace with a suitable cable described in *Motor Cables* following this section.

Termination of the braid shield at the motor must be made using a 360° bond to the motor body. This may be achieved with use of an appropriate threaded insert, or a suitable clamp. For the latter, R-clamp the braid to the rear end bell of the motor housing, as shown in the previous figure. This will not only provide a good high frequency bond, but strain relief as well.

At the drive end of the motor cable, fit a ferrite absorber over the cable before wiring to the motor connector. Locate the absorber as close as possible to the connector using heat-shrink sleeving. Expose a short length of braiding and anchor to the panel with an R-clamp. Note that the motor cable should be kept away from I/O cables carrying control signals.

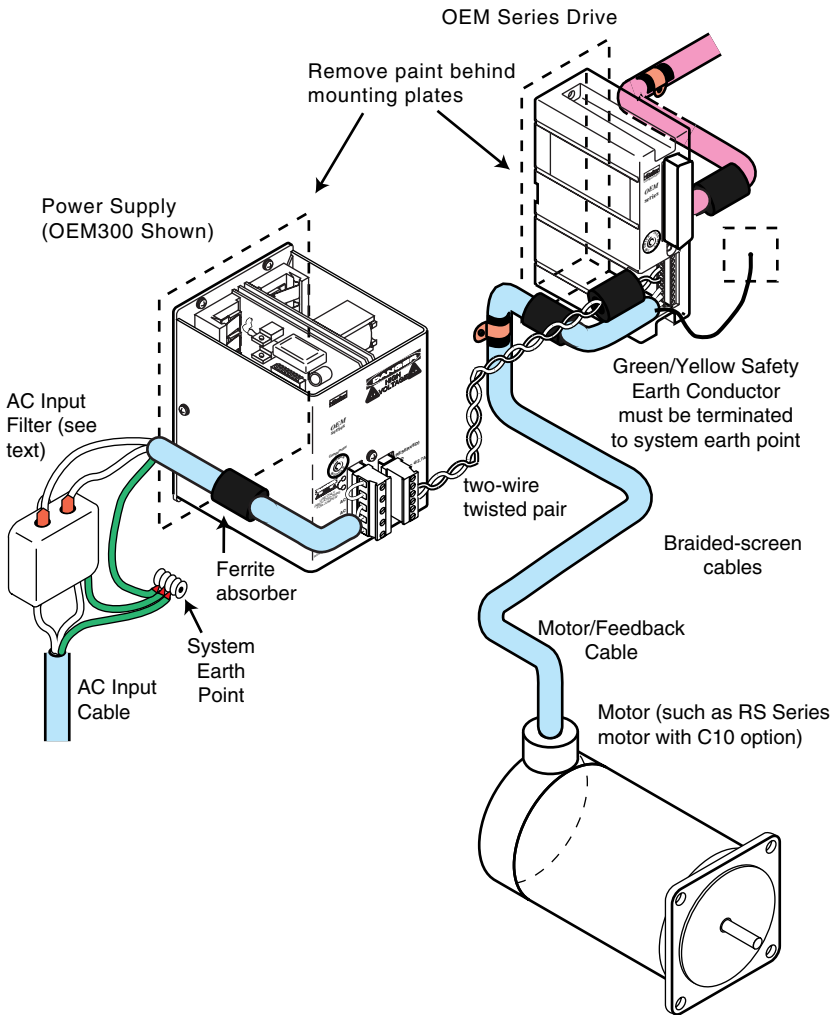

Motor with Removable Cabling

MOTOR CABLES

Use 4-core 1.5mm² (AWG 14) (SWG 16) cable for the OEM750/OEM750X.

All aftermarket motor connections must be made using a high quality braided-screen cable. Cables using a metallized plastic foil for an earth screen are unsuitable and in fact provide very little screening. Terminating to the screen in a mechanically

stable manner is difficult because the screen itself is comparatively fragile - bending it in a tight radius can seriously affect the screening performance.

There must be no break in the 360° coverage that the screen provides around the cable conductors. If a connector must be used it should retain the 360° coverage, possibly by the use of an additional metallic casing where it passes through the bulkhead of the enclosure. The cable screen must *not* be connected to the cabinet at the point of entry. Its function is to return high-frequency chopping current back to the drive or controller. This may require mounting the connector on a sub-panel insulated from the main cabinet, or using a connector having an internal screen which is insulated from the connector housing.

Within the cabinet itself, all the motor cables should lie in the same trunking as far as possible. They must be kept separate from any low-level control signal cables. This applies particularly where the control cables are unscreened and run close to the drive or other sources of electrical noise.

MOTOR FEEDBACK CABLES

Feedback devices such as encoders and tachometers also require the use of high-quality braided screen cable. If it is necessary to replace the standard feedback cable, select a braided screen cable that matches the gage of the device's original cable and attach as close to the transducer as possible. Avoid complex and bulky connections that can cause degradation in feedback signal quality. If possible, use inline cable splicing techniques, and cover the splice point with heat-shrink tubing. Remove a section of the braided shield cable's insulation to expose the braid, and tie the braid to earth using the same R-clamp 360° bond as shown in the previous figure. Differential signals should use twisted pair cable to minimize magnetic coupling. At the receiving end, R-clamp the braid to a suitable ground (metal backplane of drive mounting panel, or earth point of device that receives the feedback).

MOTORS

It is preferable to use motors with screw terminations when-

ever possible. If flying-lead motors are used, it is important that the unscreened leads are converted into a braided-screen cable within 4 inches (10cm) of the motor body. A separate terminal box may be used for this purpose but the braided cable screen must be properly strapped to the motor body. Motors fitted with terminal boxes also allow local selection of series or parallel connection, reducing the cost of the cable running back to the drive. For safety reasons, the motor case must be grounded, either through the grounded machine mounting interface or with the addition of a safety ground wire (green and yellow striped wire).

CONTROL SIGNAL WIRING

High-quality braided screen cable should be used for control connections. In the case of the OEM750/OEM750X, which has differential step/direction inputs, it is preferable to use cable with twisted pairs to minimize magnetic coupling. I/O lines require that separate grounds be individually run for each I/O point. In the case of limits and other I/O that must reside external to the mounting cabinet, braided screen cable must also be used. Bond the braid to the machine frame earth ground at the sensor end. No connection is made to the cable screen at the drive itself. Fit a ferrite absorber close to the I/O connector and run the cable to the mounting panel as shown in the previous figures. Expose a short length of the braided screen and anchor to the panel with an R-clamp.

The level at which the I/O operates means that the signals are unlikely to meet EMC immunity requirements if taken outside the enclosure without proper screening.

COMMUNICATIONS

In applications that require serial communications with the OEM750X, special care must be taken in assuring proper wiring practices are utilized. Good quality braided screen cable should be used for the communications cabling. No connection is made to the cable screen at the drive itself. Fit a ferrite absorber close to the communications connector and run the cable to the mounting panel as shown in the previous figures. Expose a short length of the braided screen and anchor to the panel with an R-clamp. Avoid routing communication cables near high power lines, and sources of high energy impulses.

This page left blank intentionally.

Index

A

absorbers 73
 AC supply filtering 72
 accessories 6
 accuracy 47
 address inputs 30
 anti-resonance 17
 attaching the load 42
 automatic standby 17
 automatic test 7, 17

C

caution notes vii
 CE Marking Directive iii, 67
 changing direction 20
 clockwise limit input 24
 closed loop operation 28
 color code
 encoders 55
 motors 8
 common problems 59
 Compumotor indexer 13
 counterclockwise limit input 24
 couplers 42
 cross reference
 motor part numbers 47
 current loop gain 18
 current range settings 10, 11, 19
 current waveform 17, 46
 curves – speed/torque 48
 CW & CCW limit inputs 24

D

daisy chaining 30
 DC supply filtering 76
 debugging tools 64
 dimensions
 encoder 55
 motor 53, 54
 DIP switch location 7
 DIP switch settings 16
 direction change 20
 direction input/output
 OEM750 20
 OEM750X 23
 double-flex coupling 42
 drive resolution 17

E

earth 67
 Electromagnetic Compatibility
 Directive iii, 71
 EMC cable connections 78
 EMC installation instructions 71
 emissions 72
 enclosures 35, 72
 encoder
 color code 55
 dimensions 55
 inputs 29
 specifications 55
 end-of-travel limits 24
 equipment cabinet 72

F

failed drive 64
 fan cooling 35
 fault LED 59
 fault output
 OEM750 21
 OEM750X 26
 features 4
 ferrite absorbers 73
 filtering
 AC supply 72
 DC supply 76

G

gain 18
 gear shift input 22
 graphic symbols 70
 ground (for RS-232C) 27

H

heatplate temperature measurement 36
 heatsink
 metric 37, 39
 OEM-HS1 37
 OEM-HS2 39
 home input 25
 hysteresis 47

I

indexer connections 13
 inductance range 4
 input filters 76
 inputs and outputs

OEM750 19
 OEM750X 23
 instability 43
 installation
 EMC 71
 LVD 67
 standard 5
 installation category 67

L

LEDs 59
 limit inputs 24
 lines (encoder) 55
 loop gain 18
 Low Voltage Directive iii, 67
 LVD installation iii, 67

M

memory
 M2 memory option 5
 metric heatsink 37, 39
 mid-range instability 43
 motor
 cooling 41
 current settings 10, 19
 EMC connections 78
 maintenance 57
 mounting 41
 parallel wiring 8
 part numbers
 cross reference 47
 resonance 43
 series wiring 8
 specifications 51
 speed/torque curves 48
 testing 62
 type 32
 waveforms 46
 mounting
 with OEM-HS1 37
 with OEM-HS2 39
 without a heatsink 35

N

non-Compumotor indexer 13
 non-Compumotor motor 10

O

OEM750
 description 1
 inputs and outputs 19
 quick test 6
 OEM750X
 description 4
 inputs and outputs 23

quick test 14
 options
 -M2 5
 high current heatsink, OEM-
 HS2 6, 39
 low current heatsink, OEM-
 HS1 6, 37
 oscillation 45
 oscilloscope method 45
 outputs 25
 overtemperature protection 36

P

panel layout 35
 parallel motor wiring 8
 part numbers
 filters 72, 76
 motors 47
 pollution degree 67
 position input 25
 power dump, and regeneration 33
 power LED 59
 power supply
 connections 12
 sizing 32
 protective conductor terminal 67
 protective earth 68

Q

quick test 6, 13, 14

R

R-clamp 74
 radiated emissions 72
 range (current range) 19
 receive input (RX tor RS-232C) 27
 reducing motor current 21
 regeneration, and power dump 33
 remote input 20
 repairing the drive 64
 repeatability 47
 resolution
 encoder 55
 motor 17
 resonance 43
 resonance speed 45, 46
 Return Material Authorization (RMA) 64
 rigid coupling 42
 RMA number 64
 RS-232C 14
 daisy chaining 30
 inputs and outputs 27
 problems 63

S

sequence inputs 26

- series motor wiring 8
- shaft modifications 41
- ship kit 5
- shutdown output 28
- sine wave current waveform 46
- single-flex coupling 42
- sinusoidal current waveforms 46
- smoothness 45
- software debugging 64
- Software Reference Manual vii
- sounding board 45
- specifications
 - drive 47
 - encoder 55
 - motor 51
- speed/torque curves 48
- standby (current standby) 17
- step input
 - OEM750 19
- step input/output
 - OEM750X 23
- stethoscope method 45
- symbols 70

T

- tachometer method 45
- technical assistance (see inside front cover)
- temperature measurement 36
- test
 - automatic test function 17
 - quick test 6, 13, 14
- testing the motor 62
- torque/speed curves 48
- transmit output (TX for RS-232C) 27
- trigger inputs 29
- troubleshooting 57
- tuning potentiometers 44
- tuning procedure 46

W

- warning notes vii
- waveforms 17, 46

This page left blank intentionally.

OEM750 DIP SETTINGS

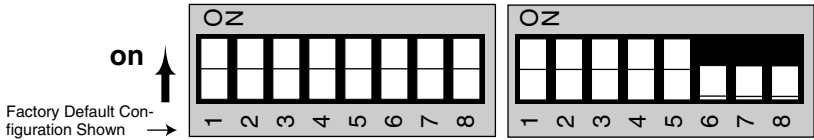

		SW 2					SW 3										
Anti-resonance		1															
	Anti-res. Disabled																
	Default Anti-res. Enabled																
Resolution (Steps per Revolution)			2	3	4	5											
	50,800	on	on	on	off												
	50,000	on	on	off	on												
	36,000	on	on	off	off												
	25,600	on	off	on	on												
	25,400	on	off	on	off												
	Default Setting 25,000	on	on	on	on												
	21,600	on	off	off	on												
	20,000	on	off	off	off												
	18,000	off	on	on	on												
	12,800	off	on	on	off												
	10,000	off	on	off	on												
	5,000	off	on	off	off												
	2,000	off	off	on	on												
	1,000	off	off	on	off												
	400	off	off	off	on												
	200	off	off	off	off												
Waveform						6	7	8									
	Pure Sine					off	off	on									
	-2% 3rd Harmonic					off	on	off									
	-4% 3rd Harmonic					off	off	off									
	Default Setting -4% 3rd Harmonic					on	on	on									
	-4% 3rd Harmonic					off	on	on									
	-6% 3rd Harmonic					on	off	off									
	-8% 3rd Harmonic					on	on	on									
	-10% 3rd Harmonic					on	on	off									
Automatic Standby									1	2							
	Default Setting Full Current								on	on							
	75% Current								off	on							
	50% Current								on	off							
	25% Current								off	off							
Automatic Test											3						
	Default Setting Automatic Test Disabled										on						
	Automatic Test Enabled										off						
Current Loop Gain												4	5	6			
												1	off	off	off		
												2	on	off	off		
												4	off	on	off		
	Default Setting											8	on	on	off		
												16	off	off	on		
												32	on	off	on		
												64	off	on	on		
												64	on	on	on		
Current Range																7	8
	Default Setting 2.5 – 7.5 amps															off	off
	0.83 – 2.5 amps															on	off
	0.7 – 2.0 amps															off	on
	0.2 – 0.7 amps															on	on

This figure is also shown on page 16, along with explanations of each function.

Internal Connections

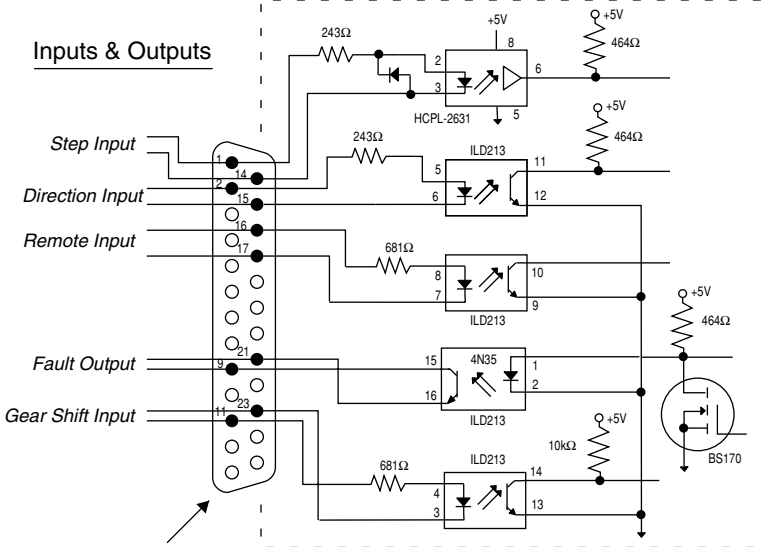

25 Pin D-Connector
Mounted on OEM750

OEM750 Inputs & Outputs, and Internal Connections

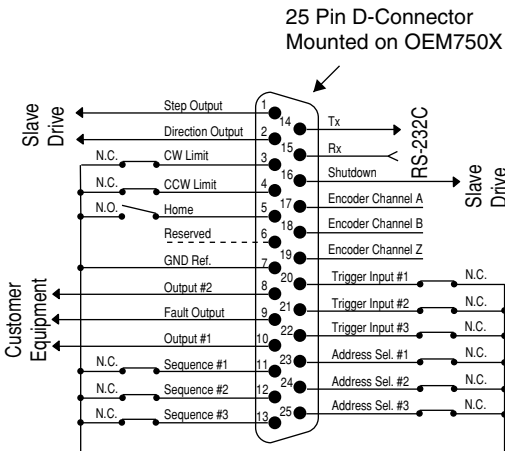

OEM750X Inputs & Outputs

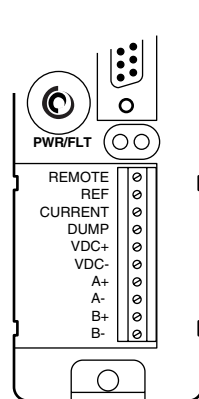

Screw Terminal Connections